

PROJEKT STRUKTURE TRUPA DVOSTRANOG TRAJEKTA DULJINE 80 m ZA JADRAN

Stanković, Maša

Master's thesis / Diplomski rad

2022

Degree Grantor / Ustanova koja je dodijelila akademski / stručni stupanj: **University of Rijeka, Faculty of Engineering / Sveučilište u Rijeci, Tehnički fakultet**

Permanent link / Trajna poveznica: <https://um.nsk.hr/um:nbn:hr:190:691861>

Rights / Prava: [Attribution 4.0 International](#)/[Imenovanje 4.0 međunarodna](#)

Download date / Datum preuzimanja: **2025-02-04**



Repository / Repozitorij:

[Repository of the University of Rijeka, Faculty of Engineering](#)



SVEUČILIŠTE U RIJECI
TEHNIČKI FAKULTET

Diplomski sveučilišni studij brodogradnje

Diplomski rad

**PROJEKT STRUKTURE TRUPA DVOSTRANOG
TRAJEKTA DULJINE 80 m ZA JADRAN**

Rijeka, studeni 2022.

Maša Stanković

0069074798

SVEUČILIŠTE U RIJECI
TEHNIČKI FAKULTET

Diplomski sveučilišni studij brodogradnje

Diplomski rad

**PROJEKT STRUKTURE TRUPA DVOSTRANOG
TRAJEKTA DULJINE 80 m ZA JADRAN**

Mentor: Prof. dr. sc. Albert Zamarin

Rijeka, studeni 2022.

Maša Stanković

0069074798

Rijeka, 19. ožujka 2022.

Zavod: **Zavod za brodogradnju i inženjerstvo morske tehnologije**
Predmet: **Čvrstoća broda**
Grana: **2.02.01 konstrukcija plovnih i pučinskih objekata**

ZADATAK ZA DIPLOMSKI RAD

Pristupnik: **Maša Stanković (0069074798)**
Studij: **Diplomski sveučilišni studij brodogradnje**
Modul: **Projektiranje i konstrukcija plovnih objekata**

Zadatak: **PROJEKT STRUKTURE TRUPA DVOSTRANOG TRAJEKTA DULJINE 80 m
ZA JADRAN / HULL STRUCTURE DESIGN OF 80 m DOUBLE-ENDED FERRY
FOR THE ADRIATIC**

Opis zadatka:

U okviru procesa projektiranja strukture trupa trajekta s obostrano ukrcajno-iskrcajnim rampama duljine 80 metara za područje plovidbe Jadranskim morem, potrebno je izraditi:

- proračun dimenzija strukturnih elemenata na glavnom rebru i pripadni nacrt,
- proračun čvrstoće globalne i lokalne strukture prema pravilima i propisima klasifikacijskog društva HRB (Hrvatski registar brodova) primjenom MATHCAD-programskog paketa,
- proračun rešetkaste primarne strukture glavne palube primjenom DNV 3D-Beam programskog alata,
- proračun okvira boka garažnog prostora primjenom DNV 3D-Beam programskog alata,
- provjeru naprezanja strukture dna uslijed dokovanja primjenom DNV 3D-Beam programskog alata,
- proračun primarne strukture nadgrađa primjenom DNV 3D-Beam programskog paketa, te
- provjeru raspodjele globalnih uzdužnih naprezanja u paralelnom srednjaku primjenom modela konačnih elemenata pomoću DNV Genie programskog paketa.

Rad mora biti napisan prema Uputama za pisanje diplomskih / završnih radova koje su objavljene na mrežnim stranicama studija.

Maša Stanković

Zadatak uručen pristupniku: 21. ožujka 2022.

Mentor:

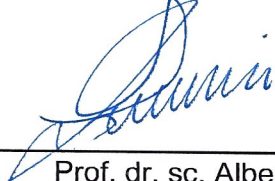

Prof. dr. sc. Albert Zamarin

Predsjednik povjerenstva za
diplomski ispit:



Prof. dr. sc. Albert Zamarin

SVEUČILIŠTE U RIJECI

TEHNIČKI FAKULTET

Diplomski sveučilišni studij brodogradnje

IZJAVA

Sukladno Pravilniku o diplomskom radu, diplomskom ispitu i završetku diplomskih sveučilišnih studija Tehničkog fakulteta u Rijeci, izjavljujem da sam samostalno izradila diplomski rad naslova "Projekt strukture trupa dvostranog trajekta duljine 80 m za Jadran" koristeći se znanjem stečenim tijekom studija, navedenom literaturom i uz konzultacije s mentorom te uz vodstvo i savijete komentora iz tvrtke Navis Consult.

Rijeka, rujan 2022.

Maša Stanković

0069074798

ZAHVALA

Zahvaljujem svom mentoru prof. dr. sc. Albertu Zamarinu na savjetima i pomoći.

Nadalje, od srca se želim zahvaliti djelatnicima tvrtke Navis Consult d.o.o. Lukši Radiću, Andreju Ugrinu i Dariu Puriću. Prvenstveno zahvaljujem na nesebično dijeljenom znanju, brojnim smjernicama te na strpljenju i vremenu koje su uložili. Također, hvala što su mi omogućili sve potrebne programske alate za izradu ovog rada.

Posebnu zahvalu želim iskazati mojoj obitelji i prijateljima.

SADRŽAJ

1. UVOD.....	4
2. BRODOVI ZA PRIJEVOZ AUTOMOBILA	5
2.1. Konstrukcija trupa.....	6
2.2. Karakteristike broda.....	7
3. DIMENZIONIRANJE STRUKTURNIH ELEMENATA PREMA PRAVILIMA KLASIFIKACIJSKOG DRUŠTVA.....	10
3.1. Materijal gradnje trupa.....	11
3.2. Opterećenja brodske konstrukcije.....	12
3.3. Oplata.....	13
3.3.1. Opločenje dna unutar 0,4 L na sredini broda.....	13
3.3.2. Plosna kobilica i dokobilični voj gredne kobilice	14
3.3.3. Opločenje boka unutar 0,4 L na sredini broda.....	14
3.3.4. Završni voj.....	14
3.4. Palube.....	14
3.4.1. Debljina lima paluba opterećenih vozilima	14
3.4.2. Debljina lima u palubama s nastambama	16
3.5. Struktura dna.....	16
3.5.1. Debljina hrptenice.....	16
3.5.2. Bočni nosači	16
3.5.3. Pokrov dvodna.....	16
3.5.4. Rebrenice	17
3.6. Orebrenje	17
3.7. Potpalubna struktura	19
3.7.1. Sponje i uzdužnjaci palube	19
3.7.2. Upore u nastambama	19
3.8. Nadgrađe.....	20
3.8.1. Bočno opločenje nadgrađa.....	20
3.8.2. Opločenje palube nadgrađa	20
3.9. Uzdužna čvrstoća.....	21

3.9.1.	Vertikalni uzdužni momenti savijanja i smične sile	21
3.9.2.	Čvrstoća pri savijanju	23
3.9.3.	Izvijanje	26
4.	PRORAČUN I PROVJERA STRUKTURNIH ELEMENATA PRIMJENOM DNV 3D-BEAM PROGRAMSKOG ALATA.....	31
4.1.	Programski alat 3D-Beam.....	31
4.2.	Rešetkasta primarna struktura glavne palube	32
4.2.1.	Opterećenje računskog modela primarne strukture glavne palube.....	33
4.2.2.	Rubni uvjeti	33
4.2.3.	Dopuštene vrijednosti naprezanja.....	34
4.2.4.	Rezultati.....	34
4.3.	Okvir boka garažnog prostora i nadgrađe.....	35
4.3.1.	Rubni uvjeti	36
4.3.2.	Opterećenje okvira boka garažnog prostora i nadgrađa	37
4.3.3.	Dopuštene vrijednosti naprezanja.....	38
4.3.4.	Rezultati.....	39
4.4.	Naprezanje strukture dna uslijed dokovanja.....	40
4.4.1.	Opterećenje strukture dna uslijed dokovanja.....	40
4.4.2.	Rubni uvjeti	41
4.4.3.	Dopuštene vrijednosti naprezanja i rezultati	42
5.	PROVJERA STRUKTURE METODOM KONAČNIH ELEMENATA.....	44
5.1.	Izrada modela.....	45
5.2.	Rubni uvjeti i opterećenje	46
5.3.	Rezultati metode konačnih elemenata	49
5.3.1.	Pregibno stanje	49
5.3.2.	Progibno stanje	54
5.3.3.	Provjera uključenosti brodske strukture u uzdužnu čvrstoću broda	60
5.4.	Zaključak MKE analize	64

6. ZAKLJUČAK	65
LITERATURA	66
POPIS SLIKA.....	67
POPIS TABLICA.....	69
POPIS OZNAKA.....	70
SAŽETAK.....	72
DODATCI.....	73

1. UVOD

Čvrstoća broda je temelj dimenzioniranja strukturnih elemenata brodskog trupa. Tri osnovna koraka čvrstoće broda su određivanje opterećenja na brodsku konstrukciju, proračun odziva tj. naprezanja i deformacija u strukturnim elementima trupa te njihovo dimenzioniranje na osnovi postavljenih uvjeta za dopuštena naprezanja. [1]

Primarni zadatak osnivanja brodske konstrukcije, osim nedvojbene funkcionalnosti, je ostvarivanje cjelovite, ujednačene i učinkovite sigurnosti tijekom cijelog radnog vijeka broda što se postiže temeljitim poznavanjem načina oštećenja i postupaka za njihovo izbjegavanje. Stoga, klasifikacijska društva ulažu velike napore kako bi izradili propise za gradnju sigurnih brodova i plovni objekata.

Tema ovog rada je izrada projekta strukture trupa dvostranog trajekta za područje plovidbe Jadranskim morem. Proračun dimenzija strukturnih elemenata na glavnom rebru te proračuni čvrstoće globalne i lokalne strukture bit će napravljeni prema pravilima i propisima Hrvatskog registra brodova, s ciljem projektiranja strukture koja je funkcionalna, sigurna te u skladu sa međunarodno priznatim tehničkim standardima.

Dobivene dimenzije će se zatim provjeriti pomoću programskog alata 3D-Beam klasifikacijskog društva Det Norske Veritas, a na kraju će se raspodjela globalnih uzdužnih naprezanja paralelnog srednjaka provjeriti metodom konačnih elemenata u FE analitičkom modulu GeniE, koji je dio Sesam programa razvijenim od strane DNV Software grupe.

2. BRODOVI ZA PRIJEVOZ AUTOMOBILA

RO-PAX trajekti su prvenstveno namijenjeni prijevozu tereta na kotačima, a tek zatim putnicima. Obično imaju barem jednu palubu za prijevoz vozila te barem jednu palubu za putnike. Razlika između RO-RO (eng. Roll-on/Roll-off) brodova i RO-PAX brodova je upravo u broju putnika. RO-RO brod može prevoziti do 12 putnika, no ako se prevozi 12 ili više putnika, riječ je o RO-RO putničkom brodu tj. RO-PAX brodu.



Slika 2.1 Primjeri RO-PAX brodova

Putnički trajekti (Slika 2.1) su specijalizirana vrsta brodova namijenjena prijevozu vozila i putnika preko vodenih površina te su pretežito linijski brodovi. Projektiraju se i grade za specifičnu relaciju te glavne dimenzije, forma trupa, kapacitet, brzina i pogon moraju odgovarati dužini i uvjetima plovidbene rute. Linijski brodovi isplovljavaju na zakazane datume, u unaprijed određeno vrijeme, bez obzira na to jesu li potpuno natovareni ili ne. Upravo radi toga, troškovi pružanja takve vrste usluge mogu biti vrlo visoki, stoga je potrebno odrediti cijene karata tj. vozarine na odgovarajući iznos kako bi se tijekom određenog vremenskog razdoblja osigurao zadovoljavajući profit.

Prema duljini plovidbene rute razlikujemo lokalne trajekte te trajekte za srednje i za velike udaljenosti. Prema obliku trupa trajekti mogu biti simetrične forme ili normalne forme broskog trupa. Kod lokalnih trajekata gdje putovanje traje kraće od 45 minuta teži se simetričnoj formi trupa s porivnicima na oba kraja. To uvelike olakšava manevriranje pri dolasku i odlasku jer se trajekt ne mora okretati za 180° te se postiže protočni ulaz i silaz vozila koji je efikasniji. Zato što trajekti često prometuju u uskim područjima moraju imati odlična kormilarska svojstva.

Dimenzije trajekata uvelike su određene vrstom vozila koja se prevozi te prostornim rasporedom istih na palubi. Najveća te najteža vozila imati će najveći utjecaj na opterećenje brodske konstrukcije. Takva vozila obično se prevoze na mjestima ili u samoj centralnoj liniji broda ili što bliže njoj te zauzimaju dvije ili više parkirnih traka standardnih dimenzija. Stoga se prilikom projektiranja RO-RO brodova moraju unaprijed definirati zahtjevi o broju i vrsta vozila koja će se prevoziti (osobni automobili, autobusi ili teška teretna vozila). Također, kod projektiranja valja uzeti u obzir i moguću varijaciju prometa s obzirom na godišnja doba.

2.1. Konstrukcija trupa

RO-RO brodovi konstrukcijski se ističu zbog svojih potpuno otvorenih, prostranih i ravnih paluba za smještaj vozila s prilaznim rampama za ukrcaj i iskrcaj. Palube se protežu od pramca do krme, bez ikakvih poprečnih pregrada, radi omogućavanja nesmetanog pristupa automobilima te drugim vozilima. Uvijek su u potpunosti ravne, bez palubnog skoka i preluka.

Klasifikacijska društva propisima određuju dimenzioniranje glavnih elemenata trupa trajekata kao i kod normalnih trgovačkih brodova. No, radi zahtjevnih uvjeta rada nerijetko se dvodno i oplata predimenzioniraju.

Geometrija brodova namijenjenih prijevozu vozila nastoji se maksimalno prilagoditi službi, stoga se brojevi upora i pregrada pokušavaju reducirati radi efikasnijeg i jednostavnijeg ukrcaja te iskrcaja vozila.

Palube za smještaj vozila su izložene velikim lokalnim statičkim opterećenjima, a prilikom kretanja vozila dolazi i do dinamičkih opterećenja. S ciljem prevencije palubnih ulegnuća između rebara, postavljaju se uzdužni interkostalni nosači kao pojačanja. Uz to, trajekte karakteriziraju i pojačani poprečni okviri koji ukrućuju i ojačavaju konstrukciju broskog trupa. Kako bi izbjegli trajne deformacije konstrukcije, izuzetno je važno ispravno dimenzionirati palube i bočne limove nadgrađa da svi elementi jednoliko preuzimaju opterećenja.

Glavne dimenzije trajekata određuju se prema potrebnoj površini za vozila. Širinu RO-RO brodova određuje se kao višestruka širina automobila tj. parkirnih mjesta plus pristupni prostor. Idealna situacija javlja se u slučaju kad se svijetla širina palube za vozila može odabrati na način da odgovara objema vrstama širina traka kod sustava traka s dvostrukom namjenom; i trakama za osobna vozila te trakama za teška vozila. Također, treba paziti da svijetla visina u garažama omogućuje najvišim vozilima neometani protočni prolaz kroz trajekt.

Rampe za ukrcaj i iskrcaj vozila su jedne od glavnih karakteristika RO-RO brodova te se upravo po njima značajno razlikuju od ostalih teretnih brodova jer ne zahtijevaju nikakvu posebnu opremu za ukrcaj i iskrcaj tereta, primjerice dizalice. Rampa je velika čelična konstrukcija, uzdužno i poprečno ojačana, a koristi se za prebacivanje tereta na kotačima s kopna u brodski trup te obratno. Nagib rampe koja povezuje palubu broda s kopnom uvelike ovisi o plimi i oseki. Prilikom prijevoza velikih kamiona i prikolica, nagib vanjskih i unutarnjih rampi održava se između 8 i 9 stupnjeva. Rampe mogu biti različitih izvedbi, kao što je prikazano na Slici 2.2, pa tako razlikujemo sklopivu krmenu rampu, bočne rampe, pramčane rampe te mobilne ili fiksne unutarnje

rampe koje služe za prijevoz vozila na više ili niže palube. Rampe se obično pomiču hidrauličkim pogonom te kad su zatvorene moraju osiguravati nepropusnost. U slučajevima kad je rampa dio vanjske brodske oplata ona mora biti dimenzionirana u skladu s relevantnim opterećenjem mora.



a) Sklopiva krmena rampa



b) Bočna rampa



c) Pramčana rampa

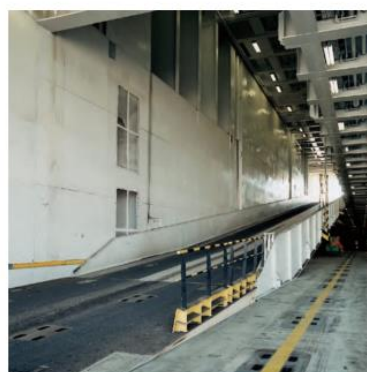

d) Fiksna unutarnja rampa

Slika 2.2 Različite izvedbe brodskih rampi

U usporedbi s ostalim tipovima brodova, trajekti moraju imati veći početni stabilitet, kako bi se pri ukrcanju i iskrcanju vozila bočni nagib minimizirao. Budući da je teret smješten relativno visoko, također je visoko i sustavno težište. Teška vozila prilikom ukrcanja i iskrcanja izazivaju velika bočna opterećenja i bočne nagibne momente, dok primjerice za vrijeme plovidbe može doći do pomaka vozila i asimetričnog opterećenja. Kako palube za smještaj vozila nemaju pregrade može doći do potpunog naplavlivanja palube vodom te se tako stvori izuzetno velika slobodna površina. Prethodni čimbenici uvjetuju da trajekti moraju imati veliki stabilitet što se postiže velikom širinom broda.

2.2. Karakteristike broda

Brod koji je tema ovog rada projektiran je kao RO-RO putnički brod s obostrano ukrcajno-iskrcajnim rampama (eng. *double ended ferry*) sa simetrijom pramac-kрма. Predviđen je za prijevoz putnika, automobila i teških vozila, a ukrcaj i iskrcaj vozila te putnika vrši se preko rampi koje se nalaze na pramcu i krmi.

Kako je brod predviđen za potrebe održavanja trajektne linije Stinica - Mišnjak, koja je glavna poveznica otoka Raba s kopnom, prema pravilima Hrvatskog registra brodova spada u Područje plovidbe 5 tj. u područje nacionalne plovidbe.

Brod je projektiran za brzinu od 12 čvorova na srednjem gazu od 2,4 m. Trajekt ima šest paluba, a vozila su smještena na pokrovu dvodna (Paluba 1) i na glavnoj palubi (Paluba 2). Na trećoj i četvrtoj palubi su saloni za putnike te smještaj za posadu. Na petoj palubi nalazi se protuljuljni tank čiji je cilj povećati udobnost plovidbe te je iznad njega kormilarnica.



Slika 2.3 Trajekt Četiri zvonika

Glavne značajke broda dane su u Tablici 2.1, a kao pomoć pri izradi ovog diplomskog rada korišten je preliminarni opći plan zadanog broda (dio prikazan na Slici 2.4) te projektna dokumentacija već izgrađenog trajekta Četiri zvonika prikazanog na Slici 2.3.

Tablica 2.1 Glavne značajke broda

Duljina preko svega	L_{OA}	79,5	m
Širina	B	18	m
Visina do glavne palube	D	4,6	m
Gaz, srednje stanje krcanja	T_1	2,4	m
Gaz, maks. stanje krcanja	T	2,6	m
Gaz, najveći konstruktivni	$T_{maks.}$	2,7	m
Koeficijent punoće istisnine	C_B	0,68	

Razmak između rebara je 600 mm, a svako četvrto rebro je okvirno.

Pri izračunu kapaciteta vozila na glavnoj palubi korištene su standardna veličina teških vozila dužine 16 m te širine 2,50 m kako bi se dobilo maksimalno palubno opterećenje tereta, a u zatvorenoj garaži prve palube, koja se nalazi na pokrovu dvodna, korištene su dimenzije standardne veličine vozila dužine 4,65 m te širine 2,20 m u koje je već uključen poprečni te uzdužni

razmak između vozila od 0,40 m. Kod teških vozila na glavnoj palubi poprečni i uzdužni razmak između vozila iznosi 0,60 m.

Prema tome, prostorno glavnu palubu moguće je opteretiti s 12 teških vozila i 10 osobnih automobila ili 96 osobnih automobila, dok na pokrov dvodna stane 41 osobni automobil.

Zanimljiva karakteristika ovog projekta je električni brodski pogon nove generacije tehnologije, bez emisije ispušnih plinova i onečišćenja zraka.

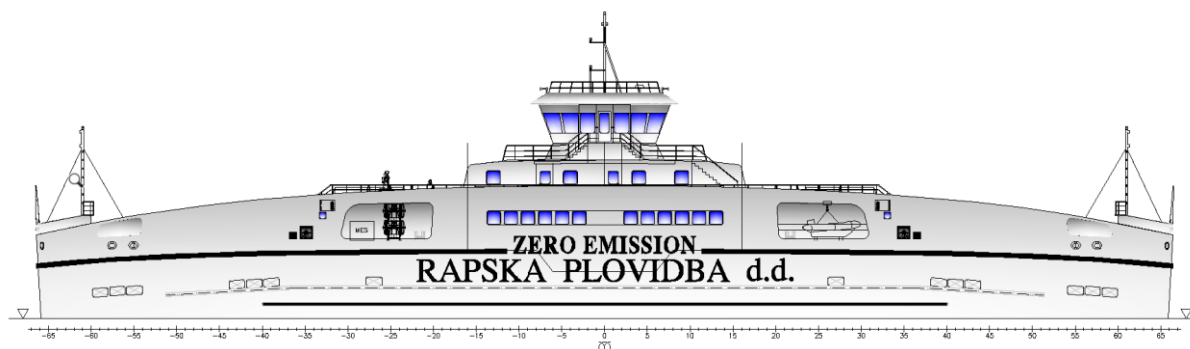

Slika 2.4 Preliminarni opći plan zadanog broda

3. DIMENZIONIRANJE STRUKTURNIH ELEMENATA PREMA PRAVILIMA KLASIFIKACIJSKOG DRUŠTVA

Dimenzioniranje strukturnih elemenata putničkog trajekta u ovom radu određeno je prema Pravilima za tehnički nadzor pomorskih brodova Hrvatskog registra brodova (u daljnjem tekstu: HRB ili Registar). Trajekt za kojeg je u ovom radu izveden proračun građen je mješovitim sustavom gradnje. Uzdužnim sustavom gradnje izvedeno je dvodno i palube, dok su bokovi i vanjska oplata iznad prve palube građeni poprečnim sustavom gradnje. Strukturna veza trupa i nadgrađa je ostvarena isključivo okvirima boka i opločenjem vanjske oplata, stoga je na nju obraćena posebna pažnja.



Slika 3.1 Hrvatski registar brodova

Glavni elementi uzdužne čvrstoće su opločenje te uzdužni strukturni elementi dna i gornjih paluba. Pod uzdužne strukturne elemente podrazumijeva se kobilica, hrptenica, podveze, bočni nosači u dvodnu te uzdužnjaci dvodna, glavne i gornjih paluba. Elementi poprečne čvrstoće su poprečna bočna rebra, rebrenice u dvodnu i transverze.

Prvi korak kod dimenzioniranja strukture je određivanje opterećenja brodske konstrukcije. Razlikujemo vanjsko opterećenje morem, opterećenja paluba teretom i nastambama, opterećenje strukture tanka i opterećenja uslijed ubrzanja. Nakon toga slijedi proračun uzdužne čvrstoće glavnog rebra s prethodno dimenzioniranim opločenjem, sekundarnom i primarnom strukturom temeljem izračuna prema pravilima Registra.

Sljedeća poglavlja ovog rada prikazati će formule i krajnje rezultate glavnih strukturnih elemenata obuhvaćenih proračunom, dok je sam proračun izveden pomoću programskog alata Mathcad te se detaljni postupci proračuna nalaze u Dodatku A, dok se u Dodatku B nalazi nacrt glavnog rebra putničkog trajekta za koji je proračun izveden. Navedeni brojevi poglavlja Hrvatskog registra brodova, naznačeni uz formule ujedno odgovaraju i brojevima poglavlja proračuna napravljenog u Mathcadu iz Dodatka A.

S ciljem lakšeg razumijevanja narednih poglavlja na Slici 3.2 nalazi se ilustracija strukturnog plana glavnog rebra.

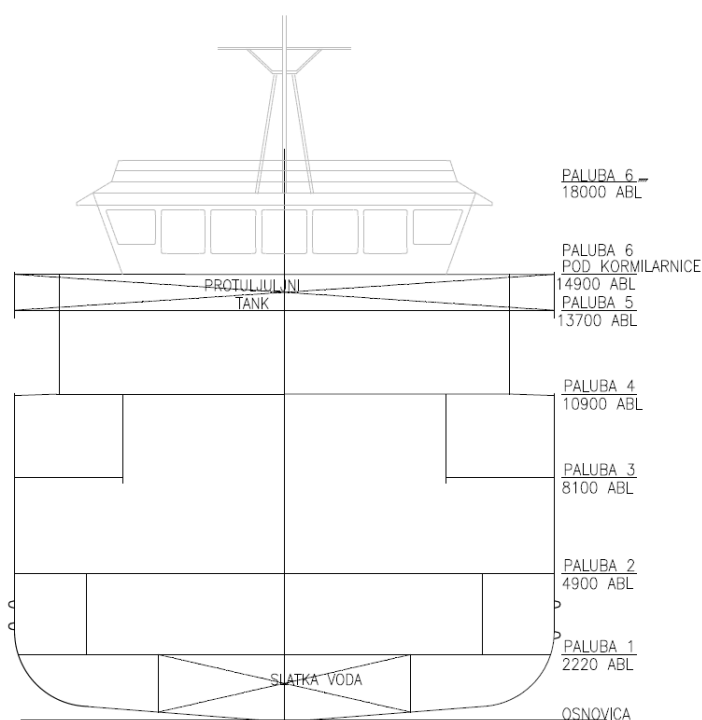

Slika 3.2 Ilustracija glavnog rebra

3.1. Materijal gradnje trupa

Kao materijal za gradnju trupa trajekta koristit će se dvije vrste brodograđevnog čelika tj. koristit će se običan čelik te čelik povišene čvrstoće. U brodograđevnoj industriji čelik je naišao na široku primjenu prvenstveno radi dobrih mehaničkih svojstva te zbog dobre zavarljivosti.

Brodograđevni čelik povišene čvrstoće je skuplji u usporedbi s brodograđevnim čelikom normalne čvrstoće, no posjeduje bolja mehanička svojstva te je njegova specifična težina manja. Stoga primjenom brodograđevnog čelika povišene čvrstoće utječemo na smanjenje ukupne mase broda jer njegova mehanička svojstva omogućuju uporabu tanjih limova i elemenata manjeg poprečnog presjeka. Čelik povišene čvrstoće koji će se koristiti za gradnju druge i treće palube je čelik kategorije AH36. Za ostale dijelove trupa koristit će se brodograđevni čelik normalne čvrstoće kategorije B. Granica razvlačenja običnog brodograđevnog čelika iznosi 235 N/mm^2 , dok je granica razvlačenja čelika povišenje čvrstoće 355 N/mm^2 .

Sukladno pravilima Hrvatskog registra brodova, u daljnjim proračunima ovog rada koeficijent materijala k za područja i elemente građene od običnog brodograđevnog čelika usvajat će se $k=1,0$, dok se za čelik povišene čvrstoće usvaja $k=0,72$.

3.2. Opterećenja brodske konstrukcije

Tablica 3.1 Opterećenja brodske konstrukcije

HRB, Poglavlje 3.2

VANJSKO OPTEREĆENJE MOREM

HRB, Poglavlje 3.2.1

Opterećenje izloženih paluba

Paluba 4			
Oplata	$p_{Ds=}$	8,059	kN/m ²
Ukrepe	$p_{Dr=}$	6,045	kN/m ²
Nosači	$p_{Dg=}$	4,836	kN/m ²

Paluba 5			
Oplata	$p_{Ds=}$	6,985	kN/m ²
Ukrepe	$p_{Dr=}$	5,239	kN/m ²
Nosači	$p_{Dg=}$	4,191	kN/m ²

HRB, Poglavlje 3.2.1.2

Minimalno opterećenje palube čvrstoće

Paluba 3			
Oplata	$p_{Dmin_s=}$	16	kN/m ²
Ukrepe	$p_{Dmin_f=}$	12	kN/m ²
Nosači	$p_{Dmin_g=}$	9,6	kN/m ²

HRB, Poglavlje 3.2.2.1

Opterećenja bokova broda

Oplata	z=1 m	$p_{s_s=}$	35,24	kN/m ²
	z=2,5 m		27,634	kN/m ²
	z=5,2 m		21,296	kN/m ²
	z=8,4 m		16,955	kN/m ²

Ukrepe	z=1 m	$p_{s_f=}$	30,68	kN/m ²
	z=2,5 m		21,226	kN/m ²
	z=5,2 m		15,972	kN/m ²
	z=8,4 m		12,717	kN/m ²

HRB, Poglavlje 3.2.3

Opterećenje brodskog dna	$p_B=$	40,31	kN/m ²
--------------------------	--------	-------	-------------------

HRB, Poglavlje 3.2.5

Opterećenja paluba nadgrađa

Paluba 6			
Oplata	$P_{DA_plating=}$	4	kN/m ²
Ukrepe	$P_{DA_stiffeners=}$	4	kN/m ²
Nosači	$P_{DA_girders=}$	4	kN/m ²

HRB, Poglavlje 3.3.1	Opterećenja paluba tereta	$p_L =$	17,087	kN/m^2
HRB, Poglavlje 3.3.2	Opterećenje pokrova dvodna	$p_{DB} =$	2,024	kN/m^2
HRB, Poglavlje 3.3.3	Opterećenje paluba nastambi	$p =$	4,03	kN/m^2
	Opterećenje paluba strojarnice	$p =$	9,211	kN/m^2

HRB, Poglavlje 3.4.1	Opterećenja punih tankova	p_1 slatka voda =	29,454	kN/m^2
		p_1 protuljlni tank =	20,005	kN/m^2
		p_2 slatka voda =	21,718	kN/m^2
		p_2 protuljlni tank =	11.908	kN/m^2
HRB, Poglavlje 3.4.2	Opterećenje djelomično napunjenih tankova	$p_{dx} =$	13,581	kN/m^2

Na presjeku glavnog rebra nalaze se dva tanka (Slika 3.2). U dvodnu se nalazi tank pitke vode koji se proteže u uzdužnom smislu od rebra -8 do rebra 8, te poprečno od L7 do L-7. Na petoj palubi se nalazi protuljlni tank koji nije napunjen do vrha, već do polovice.

Prilikom proračuna opterećenja strukture tanka, konzervativno je visina dna tanka uzeta kao mjerodavna visina za referentni tlak.

3.3. Oplata

Vanjsku oplatu broskog tupa čine oplata dna te oplata boka.

3.3.1. Opločenje dna unutar 0,4 L na sredini broda

$$HRB, Poglavlje 5.2.1 \quad t_1 = 1,9 n_1 \cdot s \cdot \sqrt{p_B \cdot k} + t_K, \text{ mm} \quad (3.1)$$

Gdje je:

$n_1 = 1,0$ za poprečno orebrenje,

$n_1 = 0,83$ za uzdužno orebrenje,

p_B – opterećenje dna, u kN/m^2 .

$$t_{1_{min}} = 7,507 \text{ mm}$$

Radi zahtijeva minimalne debljine opločenja dna propisane u Poglavlju 5.2.6 HRB, koja iznosi 8,72 mm, konačna usvojena debljina opločenja dna iznosi;

$$t_{1_{usvojen}} = 9,0 \text{ mm}.$$

3.3.2. Plosna kobilica i dokobilični voj gredne kobilice

HRB, Poglavlje 5.2.5

$$t_{KB} = t + 2,0 \text{ mm} \quad (3.2)$$

Gdje je:

t = debljina opločenja dna, u mm.

$$t_{KB} = 8,2 \text{ mm}$$

$$t_{KB_{usvojen}} = 10,5 \text{ mm}$$

3.3.3. Opločenje boka unutar 0,4 L na sredini broda

HRB, Poglavlje 5.3.1.2

$$t_s = 1,21 \cdot s \cdot \sqrt{p_s \cdot k} + t_K, \text{ mm} \quad (3.3)$$

Gdje je:

p_s – opterećenje boka, u kN/m².

$$t_{s_{min}} = 8,3 \text{ mm}$$

$$t_{s_{usvojen}} = 8,5 \text{ mm}$$

3.3.4. Završni voj

HRB, Poglavlje 5.3.4

$$t = t_s, \text{ mm}$$

$$t_{usvojen} = 8,5 \text{ mm}$$

3.4. Palube

Posebnost konstruiranja trajekata je točkasto opterećenje od djelovanja kotača vozila koje prevoze. Upravo se prema lokalnom opterećenju od kotača vozila čvrstoća palube i proračunava. Na palubu se opterećenje od kotača prenosi preko površine otiska gume. Projektno opterećenje paluba za smještaj tereta potrebno je odrediti za svaku palubu zasebno budući da se na prvoj palubi planiraju prevoziti samo osobni automobili, a na glavnoj palubi se uz automobile prevoze i teška vozila tj. kamioni.

3.4.1. Debljina lima paluba opterećenih vozilima

HRB, Poglavlje 6.2.2.1

$$t = c \cdot \sqrt{P(1 + a_v) \cdot k} + t_k, \text{ mm} \quad (3.4)$$

Gdje je:

P - opterećenje, u kN, od točka ili skupine kotača u polju lima,

a_v - koeficijent ubrzanja,

c - koeficijent ovisan o omjeru dulje i kraće stranice polja lima otiska kotača, prema Slici 3.3.

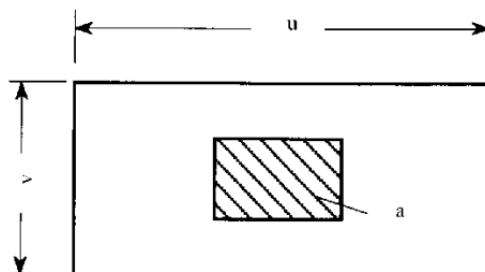

Slika 3.3 Otisak kotača na polju lima

Na slici iznad, dulja stranica polja lima označena je slovom u , dok je kraća stranica polja lima označena slovom v . Umnoškom prethodno navedenih duljina polja lima ($u \cdot v$) dobiva se površina polja lima, A . Površina otiska kotača a na slici iznad je naznačena šrafurom te je također potrebno poznavati njenu vrijednost pri određivanju koeficijenta c .

U slučajevima kad otisak kotača nije poznat, može se izračunati prema sljedećoj formuli (3.5):

HRB, Poglavlje 6.2.2.2

$$a = \frac{100 \cdot P}{p}, \text{ cm}^2 \quad (3.5)$$

Gdje je p tlak u kotačima, prema Tablici 3.2.

Tablica 3.2 Tlak u kotačima

Tip vozila	Tlak u kotačima p [bar]	
	Pneumatski kotači	Kotači od pune gume
osobna vozila	2	-
kamioni	8	-
trajleri	8	15
viljuškari	6	15

Konačno, usvajamo sljedeće debljine limova paluba za smještaj tereta:

a) Debljina lima Palube 1 opterećene osobnim automobilima:

HRB, Poglavlje 6.2.2.1

$$t_{min} = 7,6 \text{ mm}$$

$$t_{usvojen} = 8,0 \text{ mm}$$

b) Debljina lima Palube 2 opterećene teškim vozilima

HRB, Poglavlje 6.2.2.1

$$t_{min} = 13,9 \text{ mm}$$

$$t_{usvojen} = 14 \text{ mm}$$

3.4.2. Debljina lima u palubama s nastambama

HRB, Poglavlje 6.2.3

$$t = 1,1 \cdot s \cdot \sqrt{p \cdot k} + t_K, \text{ mm} \quad (3.6)$$

$$t_{min} = 6,2 \text{ mm}$$

$$t_{usvojen} = 7,0 \text{ mm}$$

3.5. Struktura dna

3.5.1. Debljina hrptenice

HRB, Poglavlje 7.2.2

$$t = \frac{h_{db}}{h_a} \cdot \left[\frac{h_{db}}{100} + 1,0 \right] \cdot \sqrt{k}, \text{ mm} \quad (3.7)$$

Gdje je:

h_{db} - visina hrptenice, mm

h_a - stvarna (ugrađena) visina hrptenice, mm

$$t_{min} = 6,64 \text{ mm}$$

$$t_{usvojen} = 8,0 \text{ mm}$$

3.5.2. Bočni nosači

HRB, Poglavlje 7.2.3

$$t = \frac{h_{db}^2}{120 \cdot h_a} \sqrt{k}, \text{ mm} \quad (3.8)$$

$$t_{min} = 4,32 \text{ mm}$$

$$t_{usvojen} = 7,5 \text{ mm}$$

3.5.3. Pokrov dvodna

HRB, Poglavlje 7.2.4

$$t = 1,1 \cdot s \cdot \sqrt{p \cdot k} + t_K, \text{ mm} \quad (3.9)$$

$$t_{min} = 5,99 \text{ mm}$$

$$t_{usvojen} = 8,0 \text{ mm}$$

3.5.4. Rebrenice

HRB, Poglavlje 7.2.6.2

$$t_p = t - 2,0\sqrt{k}, \text{ mm} \quad (3.10)$$

Gdje je:

t - debljina hrptenice.

$$t_{pmin} = 3,7 \text{ mm}$$

$$t_{pusvojen} = 8 \text{ mm}$$

3.6. Orebrenje

Orebrenje ukrepljuje i podupire vanjsku oplatu, a sastoji se od nosača usmjerenih u uzdužnom i poprečnom smjeru. Razmak rebara s iznosi 600 mm, a kako je svako četvrto rebro okvirno, razmak između okvirnih rebara S je 2400 mm.

Moment otpora glavnih rebara ne smije biti manji od iznosa dobivenog po izrazu (3.11):

HRB, Poglavlje 8.1.2

$$W = n \cdot c \cdot s \cdot l^2 \cdot p_s \cdot f \cdot k, \text{ cm}^3 \quad (3.11)$$

Gdje je:

$$n = 0,9 - 0,0035 \cdot L, \text{ za } L < 100 \text{ m};$$

$$c = 1,0 - (l_{k1} + 0,45 \cdot l_{k2});$$

l_{k1}, l_{k2} – duljina spoja donjeg/gornjeg koljena, m;

l – nepoduprti raspon, m;

p_s – opterećenje boka broda, u kN/m²,

f – koeficijent za zakrivljena rebra.

Vrijednosti dopuštenih naprezanja ne smiju biti veće od iznosa dobivenih po sljedećim izrazima:

HRB, Poglavlje 8.1.2

$$\sigma = \frac{150}{k}, \text{ N/mm}^2 \quad (3.12)$$

HRB, Poglavlje 8.1.2

$$\tau = \frac{150}{k}, \text{ N/mm}^2 \quad (3.13)$$

HRB, Poglavlje 8.1.2

$$\sigma_{ekv} = \frac{180}{k}, \text{ N/mm}^2 \quad (3.14)$$

Kao što je prethodno navedeno u Poglavlju 3.1. koeficijent materijala k , za obični brodograđevni čelik iznosi $k = 1,0$, dok se za čelik povišene čvrstoće ($R_{eH} = 355 \text{ N/mm}^2$) prema pravilima Registra uzima $k = 0,72$. Vrijednosti dopuštenih naprezanja s obzirom na koeficijent materijala prikazane su u Tablici 3.3.

Tablica 3.3 Vrijednosti dopuštenih naprezanja s obzirom na koeficijent materijala

	σ , N/mm ²	σ_{ekv} , N/mm ²	τ , N/mm ²
Obični brodograđevni čelik	150	180	100
Brodograđevni čelik povišene čvrstoće	208	250	139

Dimenzije okvirnih rebara prikazane su u Tablici 3.4.

Tablica 3.4 Dimenzije okvirnih rebara

	Struk		Flanža	
	Visina, mm	Debljina, mm	Širina, mm	Debljina, mm
Bok Palube 1 - 2	280	10	120	10
Bok Palube 2 - 3	280	10	200	20
Bok Palube 3 - 4	125	10	150	15
Bok Palube 4 - 5	150	12	225	15

Dimenzije običnih rebara iskazane su u tablici niže.

Tablica 3.5 Dimenzije običnih rebara

Bok Palube 1 - 2	HP 160 x 8
Bok Palube 2 - 3	L 150 x 90 x 9
Bok Palube 3 - 4	L 150 x 90 x 9
Bok Palube 4 - 5	L 75 x 50 x 7
Bok Palube 5 - 6	HP 120 x 7

3.7. Potpalubna struktura

3.7.1. Sponje i uzdužnjaci palube

Moment otpora sponja i uzdužnjaka palube u području od $0,25 \cdot D$ do $0,75 \cdot D$ od osnovice iznose:

Tablica 3.6 Moment otpora sponja i uzdužnjaka palube

	W_d, cm^3	A_d, cm^2
HRB, Poglavlje 9.2.1 Palube za smještaj tereta	188,179	4,228

Dimenzije okvirnih sponja prikazane su u Tablici 3.7.

Tablica 3.7 Dimenzije palubnih sponja

	Struk		Flanža		Materijal
	Visina, mm	Debljina, mm	Širina, mm	Debljina, mm	
Sponja ispod Palube 2	550	15	250	22	AH36
Sponja ispod Palube 3	190	10	200	10	AH36
Sponja ispod Palube 4	500	10	250	15	
Sponja ispod Palube 5	450	8	200	15	

Pregled usvojenih dimenzija palubnih uzdužnjaka prikazan je u Tablici 3.8.

Tablica 3.8 Dimenzije palubnih uzdužnjaka

Uzdužnjaci Palube 1	HP 160 x 8	
Uzdužnjaci Palube 2	HP 200 x 9	AH36
Uzdužnjaci Palube 3	L 100 x 50 x 7	AH36
Uzdužnjaci Palube 4	L 75 x 50 x 7	
Uzdužnjaci Palube 5	L 75 x 50 x 7	
Uzdužnjaci Palube 6	L 75 x 50 x 7	

3.7.2. Upore u nastambama

Upore se nalaze samo u prostorima nastamba. Njihovo postavljanje u garažnim prostorima izbjeglo se jer smetaju protočnom ulazu i izlasku vozila te smanjuju broj vozila koji je moguće prevesti.

Upore podupiru susjedne palube te moraju biti dimenzionirane tako da mogu podnijeti relativne poprečne deformacije između paluba te moraju biti dovoljno savitljive kako bi se spriječile koncentracije naprezanja.

$$HRB, \text{ Poglavlje 9.3} \quad t_u = 4,5 + 0,015 \cdot d_{uv} \quad (3.15)$$

Gdje je:

d_{uv} – vanjski promjer cijevne upore.

$$HRB, \text{ Poglavlje 9.3.2} \quad A_u = 10 \cdot \frac{P_u}{\sigma_t}, \text{ cm}^2 \quad (3.16)$$

Gdje je:

σ_t – dopušteno tlačno naprezanje,

P_u – opterećenje koje se prenosi.

$$A_u = 27,05 \text{ cm}^2$$

Usvojene dimenzije upora u nastambama: $\emptyset 139,7 \times 8 \text{ mm}$

3.8. Nadgrađe

3.8.1. Bočno opločenje nadgrađa

$$HRB, \text{ Poglavlje 13.2.1} \quad t = 0,8 \cdot t_{min} \quad (3.17)$$

Gdje je:

t_{min} – minimalna debljina opločenja dna, HRB, Poglavlje 5.2.6.

$$t_{usvojen} = 7 \text{ mm}$$

3.8.2. Opločenje palube nadgrađa

$$HRB, \text{ Poglavlje 13.2.2} \quad t = 1,21 \cdot s \cdot \sqrt{p \cdot k} + t_K, \text{ mm} \quad (3.18)$$

$$t_{usvojen} = 7 \text{ mm}$$

3.9. Uzdužna čvrstoća

3.9.1. Vertikalni uzdužni momenti savijanja i smične sile

Opterećenja koja djeluju na konstrukciju broda u cjelini, uzrokuju njegovo savijanje, odnosno pojavu poprečnih sila i momenata savijanja u pojedinim poprečnim presjecima brodskog nosača. U uzdužnim vezama brodske strukture momenti savijanja izazivaju normalna naprezanja, a poprečne sile smična naprezanja.

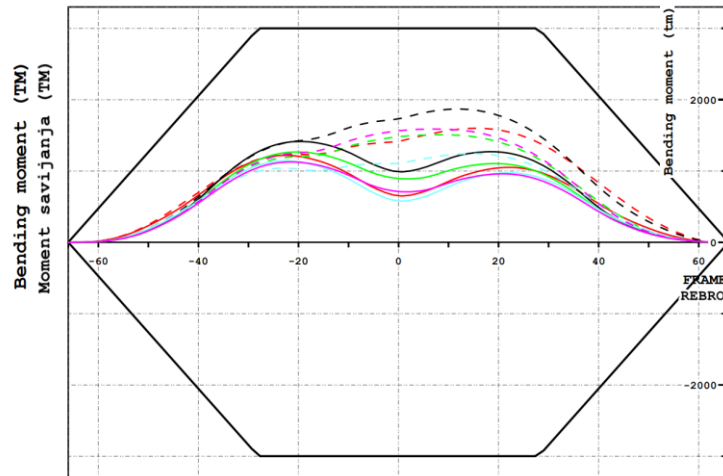

Slika 3.4 Momenti savijanja

Vrijednosti momenata savijanja na mirnoj vodi (M_w) definirane su iz raspodjele težine i uzgona duž broda tj. očitane su iz dijagrama momenta savijanja dobivenog u softveru NAPA (Slika 3.4). Sukladno tome, smična sila na mirnoj vodi dobivena je na isti način tj. očitana je s dijagrama prikazanog na Slici 3.5. Krivulja momenta savijanja je drugi integral krivulje opterećenja. Najveća vrijednost momenta savijanja javlja se na sredini broda, dok su najveće vrijednosti smičnih sila na oko 20% i 80% duljine broda od pramčane okomice.

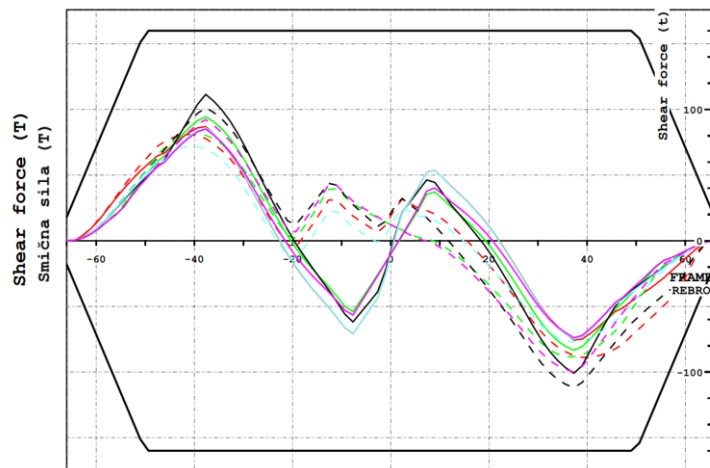

Slika 3.5 Smična sila

Kako bi bili na strani sigurnosti, projektni moment savijanja kao i usvojene smične sile uzete su znatno veće od preliminarnih iz razloga ostvarivanja zalihe prema konačnim vrijednostima. Stoga, projektni momenti savijanja te smične sile na mirnoj vodi iznose:

Tablica 3.9 Momenti savijanja i smične sile na mirnoj vodi

Pregibni moment savijanja na mirnoj vodi	M_{BH_SW}	29430	kNm	3000	TM
Progibni moment savijanja na mirnoj vodi	M_{BS_SW}	-29430	kNm	-3000	TM
Pozitivna smična sila na mirnoj vodi	$F_{s_positive}$	1569,6	kN	160	T
Negativna smična sila na mirnoj vodi	$F_{s_negative}$	1569,6	kN	160	T

Na mirnoj vodi brod je u svim slučajevima opterećenja u pregibu. Kad brod plovi na valovitom moru, situacija je drugačija jer opterećenje strukture tada, osim o rasporedu masa i uzgona, ovisi i o visini te dužini vala i dužini broda.

Moment savijanja uslijed valova proračunava se za svaki presjek uzduž broda prema izrazu:

$$M_{WH} = +190 \cdot M \cdot C_w \cdot L^2 \cdot B \cdot C_B \cdot 10^{-3}, kNm, \text{ za pregibni moment savijanja;}$$

$$M_{WS} = -110 \cdot M \cdot C_w \cdot L^2 \cdot B \cdot (C_B + 0,7) \cdot 10^{-3}, kNm, \text{ za progibni moment savijanja.}$$

Gdje je:

M – koeficijent razdiobe, prema Slici 3.6.

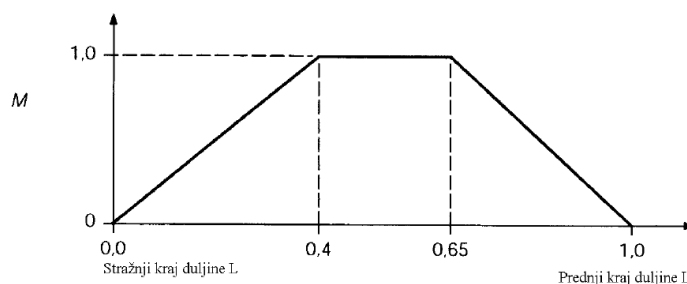

Slika 3.6 Koeficijent razdiobe M

Za brodove u ograničenoj plovidbi moment savijanja uslijed djelovanja valova mogu se umanjiti. Umanjenje za područje plovidbe 5 iznosi 25%.

Smična sila koja nastaje djelovanjem valova, F_w , na svakom poprečnom presjeku broda izračunava se po formuli:

$$F_{W\ positive} = +30 \cdot F_1 \cdot C_w \cdot L \cdot B \cdot (C_B + 0,7) \cdot 10^{-2}, kN, \text{ za pozitivnu smičnu silu;}$$

$$F_{W\ negative} = -30 \cdot F_2 \cdot C_w \cdot L \cdot B \cdot (C_B + 0,7) \cdot 10^{-2}, kN, \text{ za negativnu smičnu silu.}$$

Gdje su:

F_1, F_2 – koeficijenti raspodjele, prikazani na Slici 3.7.

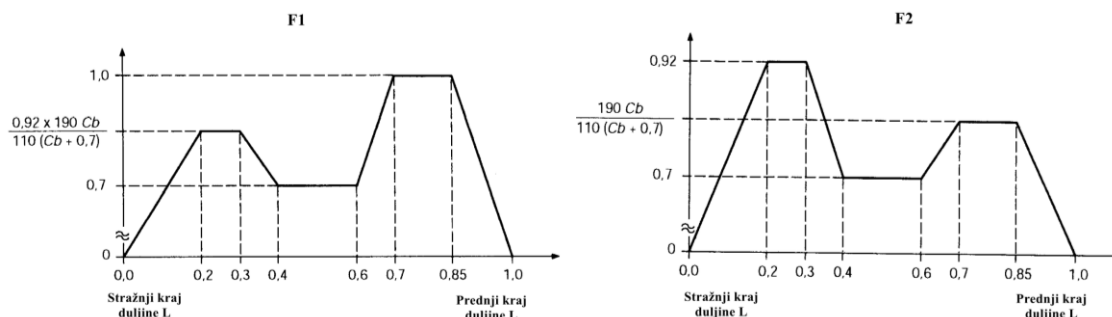

Slika 3.7 Koeficijenti raspodjele F_1 i F_2

Konačne vrijednosti pregibnog momenta savijanja i smičnih sila na valovitom moru prikazani su u Tablici 3.10.

Tablica 3.10 Momenti savijanja i smične sile na valovitoj vodi

HRB, Poglavlje 4.2.2

HRB, Poglavlje 4.2.3

Pregibni moment savijanja na valovitoj vodi	M_{WH}	69560	kNm
Progibni moment savijanja na valovitoj vodi	M_{WS}	-81720	kNm
Pozitivna smična sila na valovitoj vodi	$F_{w_positive}$	2399	kN
Negativna smična sila na valovitoj vodi	$F_{w_negative}$	-2399	kN

3.9.2. Čvrstoća pri savijanju

Otporni moment glavnog rebra izračunat je pomoću programskog alata Nauticus Hull (Slika 3.8) u kojem je modelirano glavno rebro trajekta kao što je prikazano na Slici 3.9. Za potrebe izračuna modelirani su samo uzdužni elementi strukture.



Slika 3.8 NauticusHull

Moment otpora za dno te za palubu broda računaju se prema izrazima (3.19):

$$W_D = \frac{I_y}{e_D}, \quad W_P = \frac{I_y}{e_P} \quad (3.19)$$

Gdje su:

W_D – moment otpora za dno, m^3

W_P – moment otpora za palubu, m^3

I_y – moment inercije površine glavnog rebra oko osi y, m^4

e_D – udaljenost neutralne linije do osnovice broda, m

e_P – udaljenost neutralne linije do linije glavne palube, m.

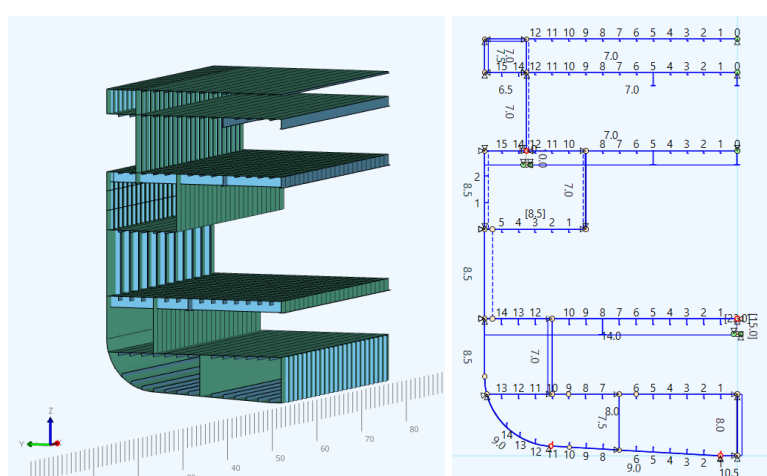

Slika 3.9 Model u Nauticus Hull

Prema izvješću iz Nauticus Hull (Tablica 3.11), neutralna linija presjeka nalazi se na visini 4,465 m od osnovice te moment inercije površine glavnog rebra oko osi y iznosi 12,069 m^4 . Iz toga slijedi da je moment otpora za dno jednak 2,703 m^3 , a moment otpora za palubu 1,876 m^3 . Zbog manje vrijednosti, za dimenzioniranje je mjerodavan palubni moment otpora.

Tablica 3.11 Svojstva presjeka iz programskog paketa NauticusHull

Površina presjeka uzdužnih elemenata	11225	cm^2
Horizontalna udaljenost od centralne linije do vertikalne neutralne linije, Y_n	0	m
Vertikalna udaljenost od osnovice do horizontalne neutralne linije, Z_n	4,465	m
Vertikalni moment inercije, I_y	12,069	m^4
Horizontalni moment inercije, I_z	39,625	m^4
Moment otpora dna, W_D	2,703	m^3
Moment otpora palube, W_P	1,876	m^3
Statički moment površine presjeka elemenata uzdužne čvrstoće oko neutralne osi	5,324	m^3
I/S	2,267	m

Moment otpora poprečnog presjeka trupa u području 0,4 L u srednjem dijelu broda ne smije biti manji od veličine dobivene po formuli (3.20):

$$HRB, \text{ Poglavlje 4.3.2} \quad W = \frac{M_S + M_W}{\sigma} \cdot 10^{-3}, \text{ cm}^3 \quad (3.20)$$

Gdje σ označava dopušteno naprezanje pri savijanju, te se dobiva po sljedećem izrazu:

$$\sigma = \frac{18,5\sqrt{L}}{k}, \text{ za } L < 90\text{m}$$

$$\sigma = 161,279 \text{ N/mm}^2$$

Iz čega slijedi:

$$W_{H_{min}} = \frac{M_{BH\ SW} + M_{WH}}{\sigma} \cdot 10^{-3} = 6,138 \cdot 10^5 \text{ cm}^3 = 0,6138 \text{ m}^3$$

$$W_{S_{min}} = \frac{M_{BS\ SW} + M_{WS}}{\sigma} \cdot 10^{-3} = 6,892 \cdot 10^5 \text{ cm}^3 = 0,6892 \text{ m}^3$$

Kriterij momenta otpora poprečnog presjeka trupa, propisan u poglavlju 4.3.2 HRB-a je ispunjen te se vrši provjera najmanjeg momenta otpora poprečnog presjeka prema poglavlju 4.3.4 iako projekt ne spada u duljinsku kategoriju zahtjeva. Stoga, moment otpora poprečnog presjeka trupa u području 0,4 L u srednjem dijelu broda ne smije ni u kojem slučaju biti manji od vrijednosti W_{min} dobivene prema (3.21):

$$HRB, \text{ Poglavlje 4.3.4} \quad W_{min} = C_w \cdot L^2 \cdot B \cdot (C_B + 0,7)k, \text{ cm}^3 \quad (3.21)$$

$$W_{min} = 8,491 \cdot 10^5 \text{ cm}^3 = 0,8491 \text{ m}^3$$

Također, vidljivo je da je zadovoljen i minimalni moment inercije površine glavnog rebra koji je propisan izrazom (3.22):

$$HRB, \text{ Poglavlje 4.3.3} \quad I_{min} = 3 \cdot \frac{L}{k} \cdot W_{min}, \text{ m}^4 \quad (3.22)$$

Te iznosi:

$$I_{min} = 1,936 \text{ m}^4$$

3.9.3. Izvijanje

Unutar ovog poglavlja provjerava se sposobnost brodske konstrukcije da se odupre izvijanju uslijed globalnih uzdužnih naprezanja. Provjera uključuje brodski trup do visine Palube 3 koja je ujedno i paluba čvrstoće. Naknadno, nakon izvršene provjere uključenosti brodske strukture u uzdužnu čvrstoću, dodatno će se na izvijanje provjeriti opločenja iznad Palube 3 na osnovi direktno očitanih uzdužnih naprezanja iz analize metodom konačnih elemenata u petom poglavlju ovog rada.

Normalno, odnosno tlačno, naprezanje u limovima (σ_E) pri izvijanju panela u elastičnom području računa se po formuli (3.23):

$$\text{HRB, Poglavlje 4.6.2.1.} \quad \sigma_E = 0,9mE \left(\frac{t_b}{1000 \cdot b} \right)^2, N/mm^2 \quad (3.23)$$

Za panele s uzdužnim elementima, koeficijent izvijanja, m računa se prema izrazu (3.24):

$$\text{HRB, Poglavlje 4.6.2.1.} \quad m = \frac{8,4}{\psi+1,1} \quad (3.24)$$

Dok za panele s uzdužnim elementima koeficijent izvijanja, m računa se po formuli (3.25):

$$\text{HRB, Poglavlje 4.6.2.1.} \quad m = c \left[1 + \left(\frac{b}{a} \right)^2 \right]^2 \cdot \frac{8,4}{\psi+1,1} \quad (3.25)$$

Vrijednosti normalnih (tlačnih) naprezanja (σ_a) pri korištenju broda dobivaju se po izrazu (3.26):

$$\text{HRB, Poglavlje 4.6.4.1.} \quad \sigma_a = \frac{M_S + M_W}{I_n} \cdot y \cdot 10^5, N/mm^2 \quad (3.26)$$

No ne smiju se uzeti vrijednosti manje od iznosa dobivenih po izrazu (3.27):

$$\text{HRB, Poglavlje 4.6.4.1.} \quad \sigma_a > \frac{30}{k} \quad (3.27)$$

Normalno kritično naprezanje (σ_c) jednako je normalnom tlačnom naprezanju u limovima (σ_E) ako je:

$$\text{HRB, Poglavlje 4.6.3.1.} \quad \sigma_E \leq \frac{\sigma_F}{2}$$

Gdje je:

σ_F – granica razvlačenja, N/mm^2 ;

$\sigma_F = 235 \text{ N/mm}^2$ za običan brodograđevni čelik, te $\sigma_F = 355 \text{ N/mm}^2$ za brodograđevni čelik povišene čvrstoće. Ako je normalno tlačno naprezanje u limovima (σ_E) veće od polovice vrijednosti granice razvlačenja (σ_E), onda se normalno kritično naprezanje (σ_c) računa prema izrazu (3.28):

$$\sigma_c = \sigma_F \left(1 - \frac{\sigma_F}{4\sigma_E}\right) \quad (3.28)$$

Pregled konačnih rezultata te vrijednosti i imena oznaka koji su korišteni pri izračunu gore navedenih izraza dani su u Tablici 3.12 za izvijanje uzdužno ukrepljenih limova, te u Tablici 3.12 za izvijanje poprečno ukrepljenih limova.

Tablica 3.12 Izvijanje uzdužno ukrepljenih limova

HRB, Poglavlje 4.6.2.1.1

			Paluba 1	Paluba 2	Paluba 3
modul elastičnosti materijala	E	N/mm ²	206000		
koeficijent izvijanja	m	-	7,636		
smanjena debljina opločenja	t _b	mm	7,50	13,50	8,00
duljina kraće stranice panela	b	m	1,2	2,4	1,2
normalno (tlačno) naprezanje	σ_E	N/mm ²	55,30	44,80	62,92

HRB, Poglavlje 4.6.4.1

moment savijanja broda na mirnoj vodi	M _s	kNm	-29430,00		
moment savijanja broda na valu	M _w	kNm	-81720,00		
moment inercije glavnog rebra	I _n	cm ⁴	1206900000,0		
duljina u vertikalnom smjeru od neutralne osi do promatrane točke	y	m	2,265	0,435	3,635
koeficijent materijala	k	-	1,00	1,00	0,72
normalno (tlačno) naprezanje	σ_a	N/mm ²	20,86	4,01	33,48

Ali normalna (tlačna) naprezanja ne uzimaju se manje od iznosa dobivenog po izrazu (3.29): $\sigma_a > \frac{30}{k}$ (3.29)

usvojeno normalno (tlačno) naprezanje	σ_a	N/mm ²	30	30	41,6
---------------------------------------	------------	-------------------	----	----	------

HRB, Poglavlje 4.6.3.1

		Paluba 1	Paluba 2	Paluba 3
σ_F	N/mm ²	235	235	355
$\frac{\sigma_F}{2}$	N/mm ²	117,5	117,5	177,5

$\sigma_c = \sigma_E$ ako je $\sigma_E \leq \frac{\sigma_F}{2}$

		$\sigma_E \leq \frac{\sigma_F}{2}$	DA	DA	DA
Projektno naprezanje, $\sigma_c = \sigma_E$	σ_c	N/mm ²	55,30	44,80	62,92

HRB, Poglavlje 4.6.5.1

		Paluba 1	Paluba 2	Paluba 3
β	-	1		
$\beta\sigma_a$	N/mm ²	30	30	41,6
$\sigma_c \geq \beta \cdot \sigma_a$		DA	DA	DA

Tablica 3.13 Izvijanje poprečno ukrepljenih limova

HRB, Poglavlje 4.6.2.1.1

			Paluba 1 - Uzdužna pregrada 6600 mm od CL	Paluba 2 - Bok (9000 mm od CL)	Paluba 3 - Unutarnja rebra salona (Uzdužna pregrada 5400 mm od CL)	Paluba 3 - Vanjska rebra salona (9000 mm od CL)
modul elastičnosti materijala	E	N/mm ²	206000			
koeficijent izvijanja	m	-	1,590	1,297	2,368	2,368
smanjena debljina opločenja	t _b	mm	6,50	8,00	6,50	8,00
duljina kraće stranice panela	b	m	0,6	0,6	0,6	0,6
duljina dulje stranice panela	a	m	2,7	3,2	0,95	0,95
koeficijent korekcije	c	-	1,1	1,21	1,21	1,21
normalno (tlačno) naprezanje	σ_E	N/mm ²	34,59	42,74	51,52	78,04

HRB, Poglavlje 4.6.4.1

			Paluba 1 - Uzdužna pregrada 6600 mm od CL	Paluba 2 – Bok (9000 mm od CL)	Paluba 3 - Unutarnja rebra salona (Uzdužna pregrada 5400 mm od CL)	Paluba 3 - Vanjska rebra salona (9000 mm od CL)
moment savijanja broda na mirnoj vodi	M_s	kNm	-29430,00			
moment savijanja broda na valu	M_w	kNm	-81720,00			
moment inercije glavnog rebra	I_n	cm ⁴	1206900000,0			
duljina u vertikalnom smjeru od neutralne osi do promatrane točke	y	m	-1,750	-1,11	5,193	5,927
koeficijent materijala	k	-	1,00			
normalno (tlačno) naprezanje	σ_a	N/mm ²	16,12	10,22	47,83	54,58

Ali normalna (tlačna) naprezanja ne uzimaju se manje od iznosa dobivenog po izrazu (3.30): $\sigma_a > \frac{30}{k}$ (3.30)

usvojeno normalno (tlačno) naprezanje	σ_a	N/mm ²	30,00	30,00	47,83	54,58
---------------------------------------	------------	-------------------	-------	-------	-------	-------

HRB, Poglavlje 4.6.3.1

σ_F	N/mm ²	235
$\frac{\sigma_F}{2}$	N/mm ²	117,5

$\sigma_c = \sigma_E$ ako je $\sigma_E \leq \frac{\sigma_F}{2}$

			$\sigma_E \leq \frac{\sigma_F}{2}$	DA	DA	DA	DA
Projektno naprezanje, $\sigma_c = \sigma_E$	σ_c	N/mm ²	34,59	42,74	51,52	78,04	

HRB, Poglavlje 4.6.5.1

β	-	1			
$\beta \sigma_a$	N/mm ²	30,00	30,00	47,83	54,58
$\sigma_c \geq \beta \cdot \sigma_a$		DA	DA	DA	DA

Inicijalno projektno naprezanje σ_c pri izvijanju limova unutarnjih i vanjskih rebara salona na trećoj palubi bez ukrepa nije bilo u skladu s izrazom $\sigma_c \geq \beta \cdot \sigma_a$, stoga ih je bilo potrebno još dodatno

učvrstiti protiv izvijanja. Zato su na unutarnjim rebrima salona postavljene dvije ukrepe protiv izvijanja FB 75 x 8 mm, dok su na vanjskim rebrima salona postavljena dva holland profila dimenzija HP 120 x 8 mm. Iz prethodne tablice je vidljivo da je uvjet zadovoljen.

4. PRORAČUN I PROVJERA STRUKTURNIH ELEMENATA PRIMJENOM DNV 3D-BEAM PROGRAMSKOG ALATA

4.1. Programski alat 3D-Beam

DNV 3D Beam (Slika 4.1) je aplikacija za linearnu statičku analizu 2D i 3D okvirnih struktura razvijena od strane DNV GL te se distribuira kao dio programa Nauticus.



Slika 4.1 Nauticus 3D Beam programski alat

Primarna struktura broda idealizira se u gredni model gdje je okvir konstrukcije idealiziran čvorovima, gredama i nosačima. Program se temelji na metodi matričnog pomaka. Elastične grede se analiziraju kao tzv. Timošenkove grede što podrazumijeva da je kut između linije grede i normale poprečnog presjeka proporcionalan posmičnoj sili. Timošenkova teorija savijanja greda upotrebljava se kod greda znatno većih debljina gdje utjecaj smika nije zanemariv. Premisa Timošenkove teorije savijanja grede je da poprečni presjeci ostaju ravni, no uslijed kutne deformacije koja je rezultat smičnog naprezanja dolazi do deplanacije te poprečni presjek nije više okomit na elastičnu liniju.

Kod proračuna čvrstoće, stvarnu brodsku konstrukciju nadomještamo matematičkim modelom. Dio konstrukcije koji se proračunava se izdvaja te se elementi koji nisu od velikog značaja zanemaruju, a utjecaj preostalog djela konstrukcije se nadomještava rubnim uvjetima. Što je matematički model vjerniji stvarnoj konstrukciji i njenoj geometriji te opterećenjima, to će rezultati izračuna biti točniji. [4]

Izrađena su tri zasebna modela u 3D-Beam programskom alatu: rešetkasti model primarne strukture glavne palube, model okvira boka garažnog prostora i nadgrađa te model rebrenice pomoću kojeg se ispitalo naprezanje strukture dna uslijed dokovanja.

Svi 3D Beam modeli izrađeni na temelju dimenzija proračunatih prethodnim poglavljem te prema nacrtu glavnog rebra iz Dodatka B.

4.2. Rešetkasta primarna struktura glavne palube

Paluba 2, na visini od 4900 mm od osnovice ujedno je i glavna paluba. Za potrebe proračuna modelirana je primarna struktura paralelnog srednjaka glavne palube od rebra -16 do rebra 16 (Slika 4.2). Rešetkastu primarnu strukturu glavne palube čini više ukrižanih greda istih karakteristika tj. riječ je o T profilima okvirnih sponja i palubnih proveza dimenzija struka 550 x 15 mm te flanže 250 x 22 mm. Detaljne informacije o samom modelu prikazane su u Dodatku C.

Radi visinskih ograničenja u području donje garaže korišten je brodograđevni čelik povišene čvrstoće s granicom razvlačenja $R_{eH} = 355 \text{ N/mm}^2$, kako bi se maksimalno reducirala visina struka okvirnih sponja.

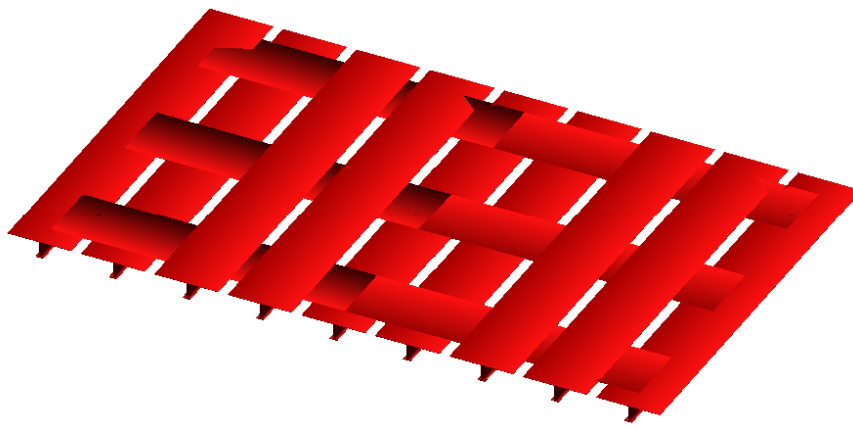

Slika 4.2 3D Beam model primarnih strukturnih elemenata glavne palube

Numeracija greda i čvorova modela prikazana je na slici niže. Svijetloplavi brojevi označavaju broj čvorova, dok su brojevi greda označeni tamnoplavom bojom.

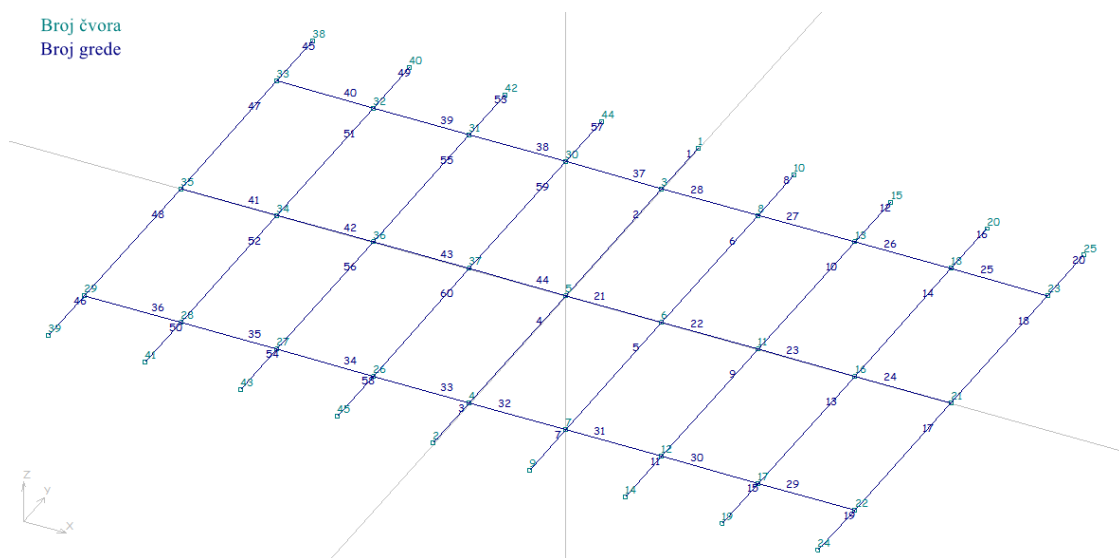

Slika 4.3 Numeracija čvorova i greda modela glavne palube

4.2.1. Opterećenje računskog modela primarne strukture glavne palube

Opterećenje je sačinjeno kao kombinacija tri osnovna opterećenja:

- LC1 - Vlastita težina,
- LC2 - Statičko maksimalno osovinsko opterećenje,
- LC3 - Dinamičko opterećenje uslijed maksimalnih vertikalnih akceleracija.

Palubna struktura je potom u slučaju opterećenja LC2 transverzalno opterećena silom od 44 N/mm (Slika 4.4) što simulira osovinsko opterećenje najtežeg predviđenog tipa tereta koje će trajekt prevoziti tj. predstavlja opterećenje kamiona. U slučaju opterećenja LC3 glavna paluba opterećena je dinamički.

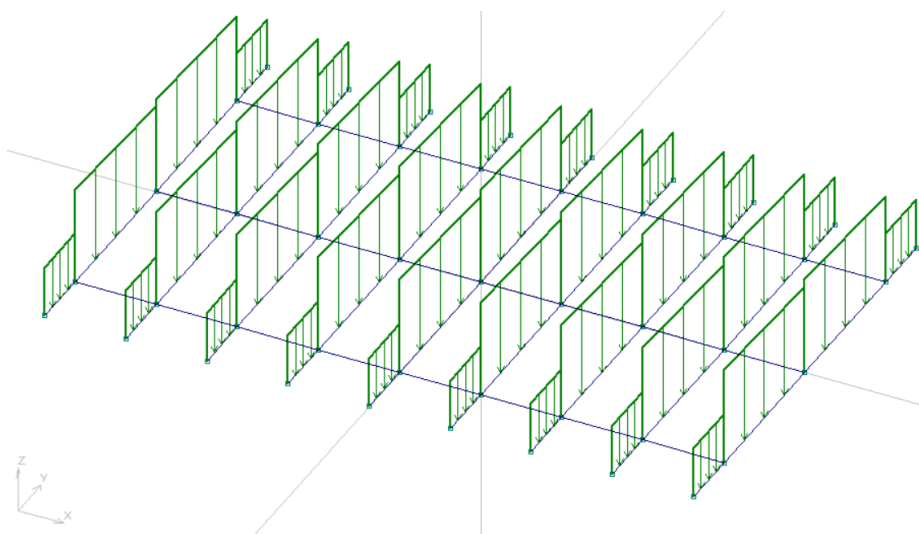

Slika 4.4 Opterećenja na model

4.2.2. Rubni uvjeti

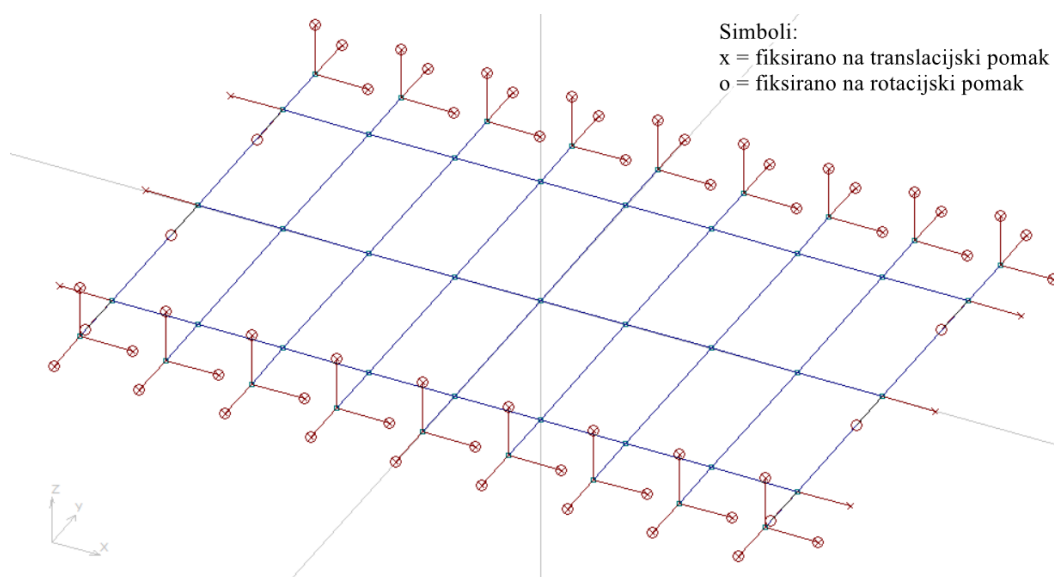

Slika 4.5 Rubni uvjeti

Rubni uvjeti modela glavne palube prikazani su na prethodnoj slici te u tablici niže. Na spoju okvirnih sponja sa jakim okvirima boka zaključane su svih 6 sloboda kretanja, dok su na uzdužne nosače primijenjeni rubni uvjeti koji sprječavaju uzdužnu translaciju i poprečnu rotaciju nosača iz razloga njihove kontinuiranosti izvan granica računskog modela.

Tablica 4.1 Rubni uvjeti modela rešetkaste primarne strukture glavne palube

		R0, R4, R8, R12, R16, R-4, R-8, R-12, R-16	L0, L-8, L8
Translacijski pomak	X	fiksni	fiksni
	Y	fiksni	slobodan
	Z	fiksni	slobodan
Rotacijski pomak	X	fiksni	slobodan
	Y	fiksni	fiksni
	Z	fiksni	slobodan

4.2.3. Dopuštene vrijednosti naprezanja

Rezultati dobiveni analizom naprezanja u 3D-Beam programskom alatu moraju biti manja od maksimalno dopuštenih vrijednosti naprezanja prikazanih Tablicom 4.2 kako bi pravila Registra bila zadovoljena.

Tablica 4.2 Dopuštene vrijednosti naprezanja brodograđevnog čelika povišene čvrstoće

	σ , N/mm ²	σ_{ekv} , N/mm ²	τ , N/mm ²
Maksimalno dopuštene vrijednosti naprezanja	208	250	138

4.2.4. Rezultati

Dimenzije primarnih strukturnih elemenata glavne palube pomoću programskog alata 3D Beam provjerene su prema HRB pravilima. Iz tablica „Beam Stresses“ i „Effective Stress“ u Dodatku C vidimo da su sve vrijednosti naprezanja ispod maksimalno dopuštenih vrijednosti naprezanja brodograđevnog čelika povišene čvrstoće navedenih tablično u prethodnom poglavlju, stoga zaključujemo da roštiljna konstrukcija glavne palube zadovoljava uvjete čvrstoće te da je ispravno dimenzionirana.

Na slici niže prikazan je pomak konstrukcije glavne palube uslijed opterećenja. Kao što se moglo i očekivati, najveći pomak u iznosu od 13,807 mm je na sredini u negativnom smjeru osi z.

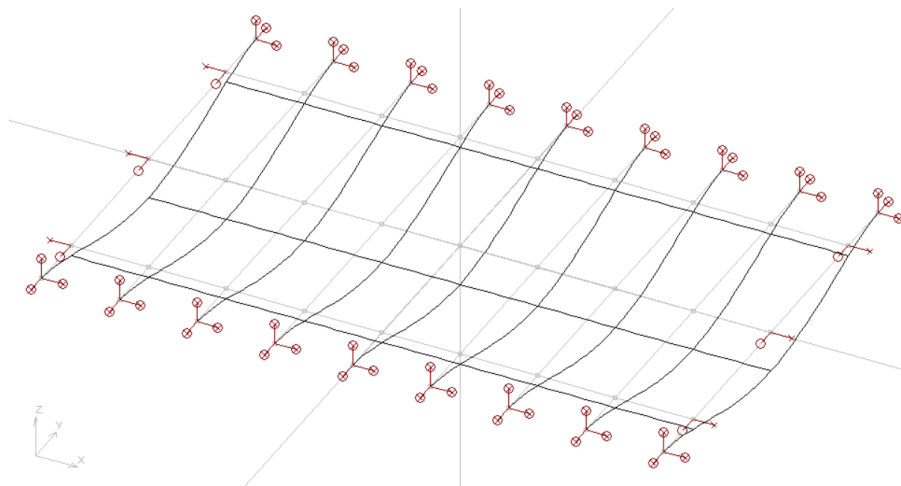

Slika 4.6 Pomak strukture glavne palube

4.3. Okvir boka garažnog prostora i nadgrađe

Za potrebe proračuna okvira boka garažnog prostora modeliran je paralelni srednjak trajekta od rebra -16 do rebra 16 te po visini od glavne palube na visini od 4900 mm sve do kormilarnice na visini od 18000 mm. Model je simetričan s obzirom na glavno rebro te je prikazan na Slici 4.7. Struktura kormilarnice i protuljuljnog tanka predstavljena je pojednostavljeno kako bi se uzelo u obzir maseno opterećenje na strukturu ispod. Proračun primarne strukture kormilarnice i protuljuljnog tanka bit će zasebno izveden u kasnijoj projektnoj fazi koja nije dio fokusa ovog rada.

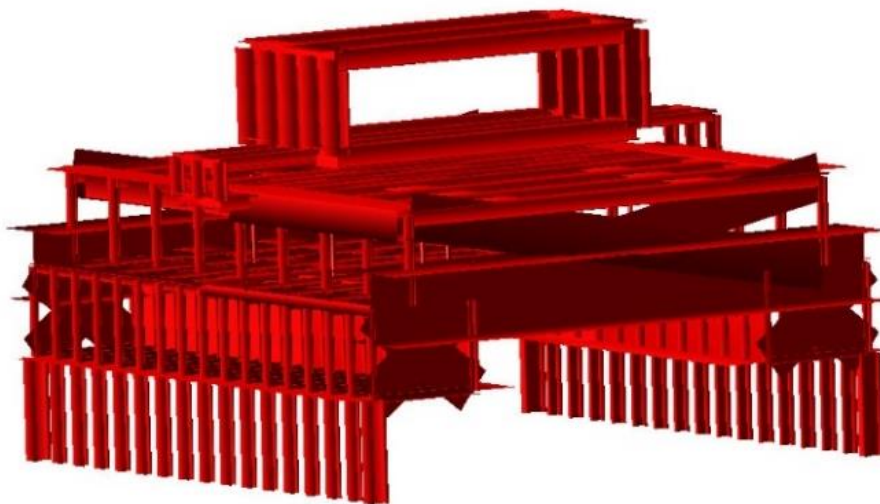

Slika 4.7 Model okvira boka garažnog prostora

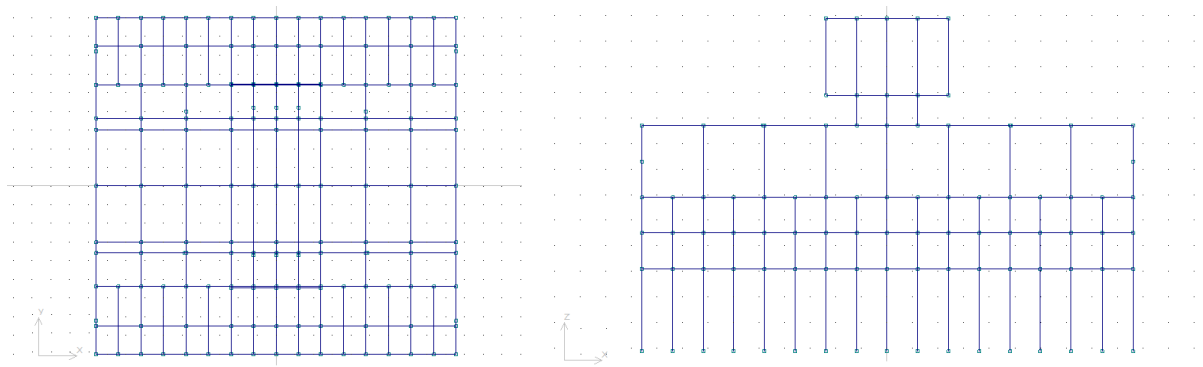

Slika 4.8 Prikaz modela okvira boka u xy i xz ravninama

4.3.1. Rubni uvjeti

Primjenom rubnih uvjeta sprečavaju se translacijski i rotacijski pomaci modela kao krutog tijela te su prikazani na Slici 4.9 te tablično u Tablici 4.3. Oslonci su postavljeni na jaku strukturu glavne palube radi preuzimanja mogućih sila reakcija.

Tablica 4.3 Rubni uvjeti modela okvira boka

		R0, R4, R8, R12, R16, R-4, R-8, R-12, R-16	R2, R6, R10, R14 R-2, R-6, R-10, R-14
Translacijski pomak	X	fiksni	fiksni
	Y	fiksni	fiksni
	Z	fiksni	fiksni
Rotacijski pomak	X	fiksni	fiksni
	Y	fiksni	slobodan
	Z	fiksni	slobodan

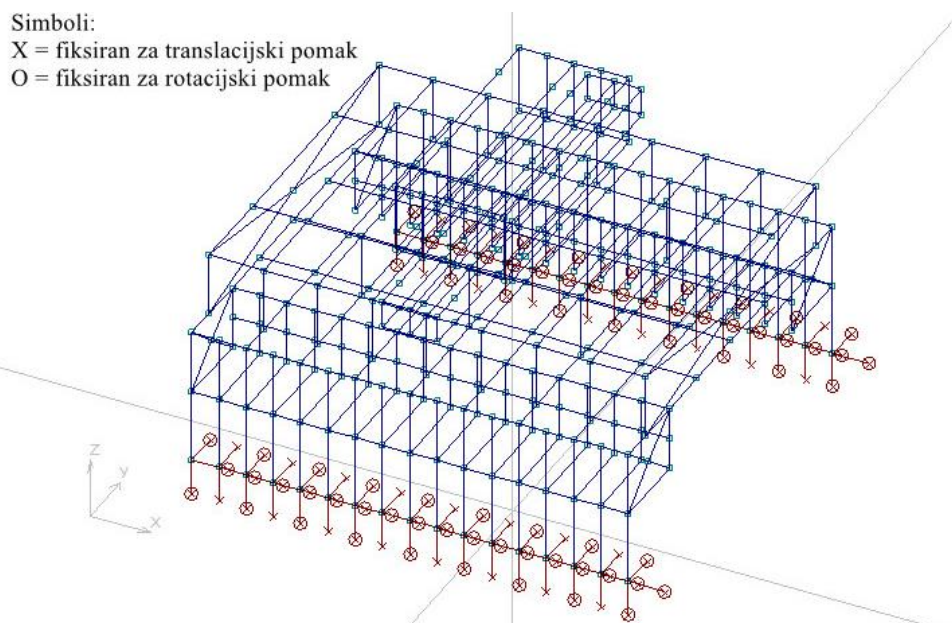

Slika 4.9 Rubni uvjeti modela okvira boka

4.3.2. Opterećenje okvira boka garažnog prostora i nadgrađa

Na model okvira boka garažnog prostora aplicirana su sljedeća tri slučaja opterećenja:

- LC1 - Poprečno akceleracijsko polje
- LC2 - Palubna opterećenja i vlastita težina
- LC3 - Opterećenje od vjetra

Poprečno akceleracijsko polje koje je primijenjeno na model izračunato je prema poglavlju 3.5 pravila Hrvatskog registra brodova, te bezdimenzijska komponenta poprečnog ubrzanja (okomito na bok) uslijed zanošenja, zaošijanja i valjanja iznosi:

$$a_y = 0,645$$

Bezdimenzijska komponenta poprečnog ubrzanja zatim se množi s gravitacijskim ubrzanjem:

$$a_y = 0,645 \cdot 9,81 = 6,327 \text{ m/s}^2.$$

Drugi slučaj opterećenja, LC2, uključuje palubno opterećenje te vlastitu težinu konstrukcije. Sve mase predstavljene su skaliranjem gustoće materijala kako bi odgovarale stvarnim masama na brodu. Faktor masa dobiven je kao kvocijent stvarne mase dobivene iz knjige centracija masa i početne mase modela u 3D Beamu, potom je gustoća materijala korigirana. Korigirana gustoća, u kg/m^3 , prikazana je na 31. stranici Dodatka D, u stupcu *Density* tablice *Materials*.

Kod palubnog opterećenja, prikazanih na Slici 4.10, na jedan poprečni okvir nanosi se opterećenje koje se nalazi na jednom okvirnom razmaku. Također, u obzir se mora uzeti i težina vode na izloženim palubama uslijed valova i nemirnog mora.

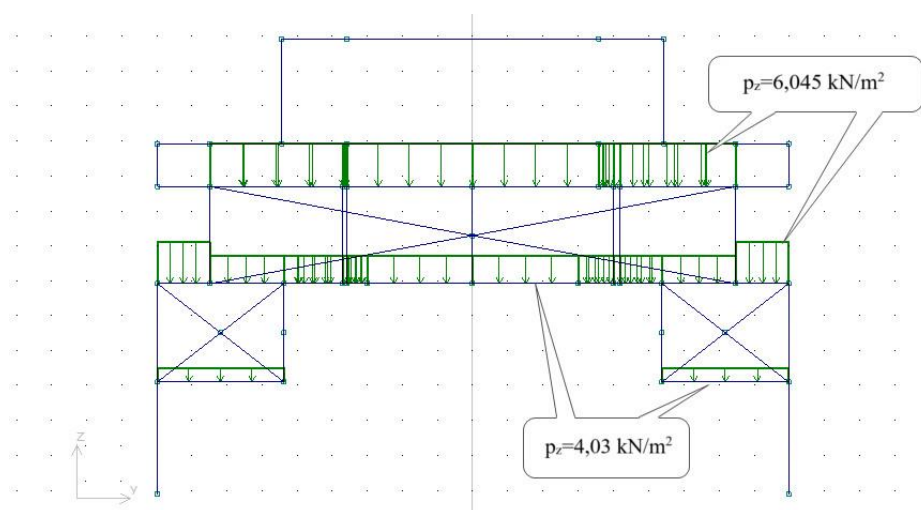

Slika 4.10 Palubna opterećenja

Nadalje, brod mora imati sposobnost da podnese djelovanje loših vremenskih uvjeta. Glavni primjer je jak bočni vjetar. Utjecaj vjetra na brod ovisi o lateralnoj površini tj. o površini iznad vodne linije te o brzini i smjeru vjetra. Stoga, brodovi s većim nadgrađima su izloženiji utjecaju vjetra. Za potrebe ovog rada, u trećem slučaju opterećenja LC3 (Slika 4.11), utjecaj vjetra određen je za tri različita područja u ovisnosti o sunosivoj površini pod utjecajem vjetra, a prema sljedećoj formuli (4.1):

$$F_{vj} = \frac{1}{2} \cdot \rho_{zr} \cdot v^2 \cdot A \quad (4.1)$$

Tablica 4.4 Proračun linearnih opterećenja vjetra

		Paluba 2 - Paluba 4	Paluba 4 - Paluba 5	Kormilarnica
Jedinična površina	A [m]	1,2	2,4	1,68
Gustoća zraka	ρ_{zr} [kg/m ³]	1,22		
Brzina vjetra	v [m/s]	30		
Opterećenje od vjetra	F_{vj} [N/m]	658,8	1317,6	924,8
	F_{vj} [N/mm]	0,6588	1,3176	0,9248

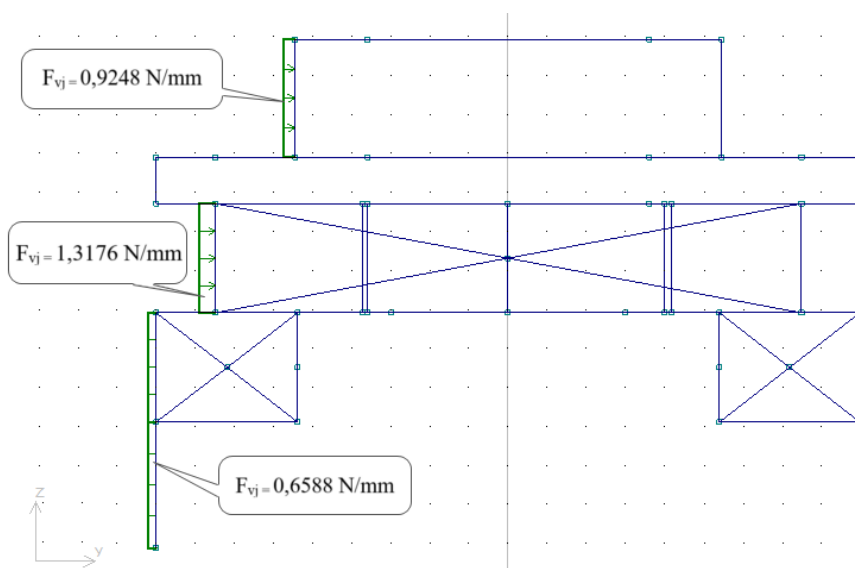

Slika 4.11 Opterećenje od vjetra

4.3.3. Dopuštene vrijednosti naprezanja

Kriteriji prihvatljivosti za brodograđevni čelik normalne čvrstoće su:

$$\sigma = 150 \text{ N/mm}^2$$

$$\sigma_{ekv} = 180 \text{ N/mm}^2$$

$$\tau = 100 \text{ N/mm}^2$$

Kriteriji prihvatljivosti za brodograđevni čelik povišene čvrstoće (čelik granice razvlačenja 355 N/mm²) su:

$$\sigma = 208 \text{ N/mm}^2$$

$$\sigma_{ekv} = 250 \text{ N/mm}^2$$

$$\tau = 138 \text{ N/mm}^2$$

4.3.4. Rezultati

U Dodatku D vidljivo je da svi elementi, osim gređa broj 307 i 310, zadovoljavaju prethodno navedene kriterije. Gređe 307 i 310 modelirane su kao čelone pregrade salona na četvrtoj palubi, no u stvarnosti su dio nosača koji predstavlja poprečnu pregradu velike krutosti. Samim time rezultirajuća naprezanja nisu realna te će biti provjerena metodom konačnih elemenata u sljedećoj projektnoj fazi koja nije dio fokusa ovog rada. Pomak strukture nakon primjene tri slučaja opterećenja prikazan je na slici niže.

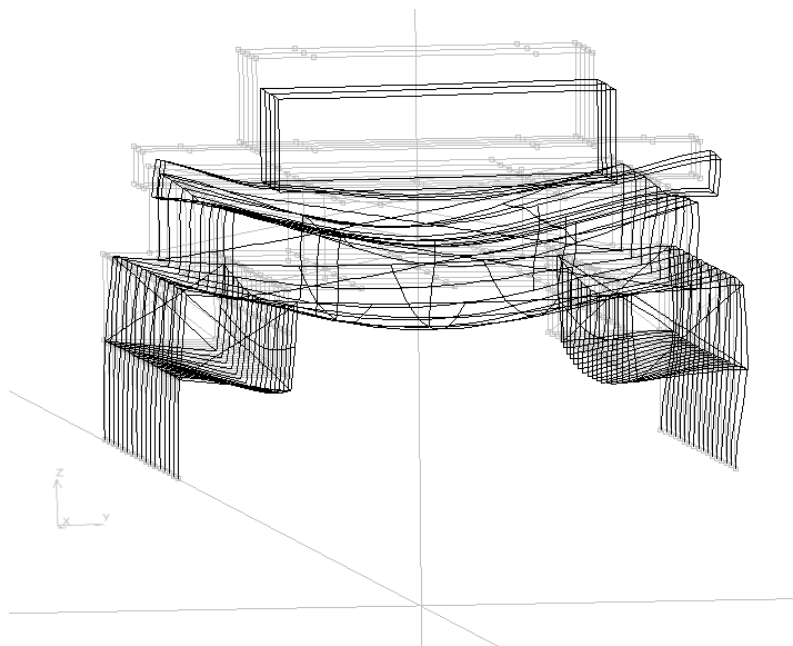

Slika 4.12 Pomak strukture nakon aplikacije tri slučaja opterećenja

Poprečno klimanje broda (eng. racking) je kritično kod trajekata zato što je se veza nadgrađa s trupom ostvaruje samo preko strukture oplate boka. Ovaj problem je najizraženiji u slučajevima valjanja trupa broda u kombinaciji s visokim brzinama bočnog vjetrova. Rješenje prethodno navedenog problema su jaki okvirni nosači boka.

4.4. Naprezanje strukture dna uslijed dokovanja

S obzirom na veliku visinu dvodna provjera strukture dna uslijed dokovanja će biti izvedena na razini jedne rebrenice. Očekivane razine naprezanja su vrlo niske, uz monotonu strukturu dna, te stoga nema potrebe za razvijanjem trodimenzionalnog modela. Za potrebe provjere načinjen je raniji plan dokovanja sa marginom na inicijalno izračunatu istisninu pri dokovanju od 25%. Spomenuta margina uključuje eventualnu nepreciznost pri ranom određivanju istisnine, kao i nejednakosti u intenzitetu sile pojedinog oslanjanja.

$$\Delta = 1500 \cdot 1,25 = 1875 \text{ t}$$

4.4.1. Opterećenje strukture dna uslijed dokovanja

Cijelo opterećenje prilikom dokovanja je za potrebe ovog proračuna distribuirano u centralnoj liniji, gdje se nalazi 29 potklada dimenzija 1200 x 500 mm (Slika 4.13). Za bočnu stabilnost postavljaju se potklade izvan područja centralne linije, a u području poprečnih ili uzdužnih pregrada. Prilikom dokovanja, težinu broda preuzimaju potklade. Sila u potkladama prilikom dokovanja izračunata je prema sljedećem izrazu (4.2):

$$P_{Z_{dok}} = \frac{\Delta}{n}, \quad (4.2)$$

gdje je n broj potklada u centralnoj liniji tj. $n = 29$.

$$P_{Z_{dok}} \approx 65 \text{ t} = 637650 \text{ N}$$

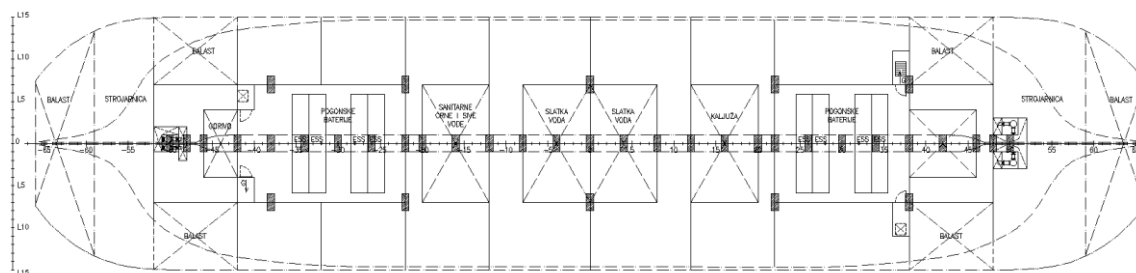

Slika 4.13 Plan potklada

Model rebrenice je stoga opterećen silom od 637,65 kN u centralnoj liniji kako bi se simulirala sila pri dokovanju (Slika 4.14). Kao i u prethodnom poglavlju, brojevi čvorova prikazani su svijetloplavim brojevima, a grede su numerirane tamnoplavim brojevima.

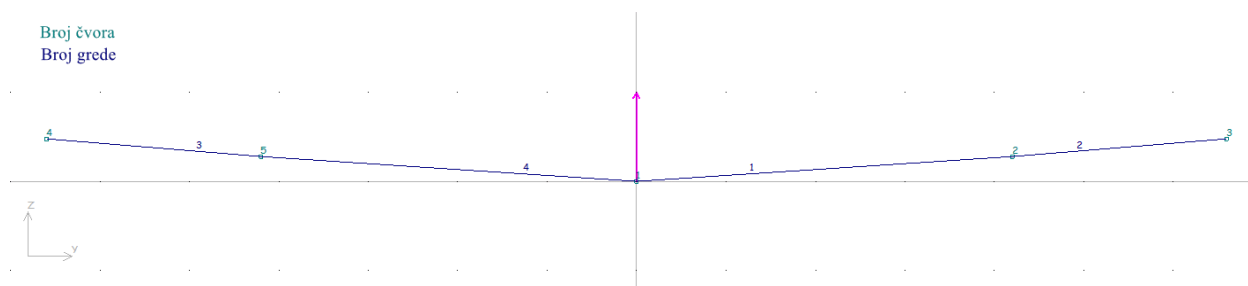

Slika 4.14 Rebrenica opterećenja silom dokovanja

Konzervativno je zanemaren doprinos primarne uzdužne strukture dna. Proračun je izveden za rebra gdje su rebrenice propusne jer je situacija u tom slučaju nepovoljnija nego u usporedbi s nepropusnim rebrenicama. Nepovoljnija situacija proizlazi iz smanjenog ekvivalentnog momenta inercije nosača te smanjene ekvivalentne debljine struka u slučaju nepropusne rebrenice koja tipično ima izreze u limu struka.

4.4.2. Rubni uvjeti

Postavljeni rubni uvjeti fiksni na sve rotacijske i translacijske pomake na 6600 mm od centralne linije (L11 i L-11), ova točka predstavlja oslonac rebrenice u vidu uzdužne pregrade trupa. Detalji rubnih uvjeta prikazani su u Tablici 4.5 te na Slici 4.15.

Tablica 4.5 Rubni uvjeti modela prilikom dokovanja

		L11, L-11
Translacijski pomak	X	fiksni
	Y	fiksni
	Z	fiksni
Rotacijski pomak	X	fiksni
	Y	fiksni
	Z	fiksni

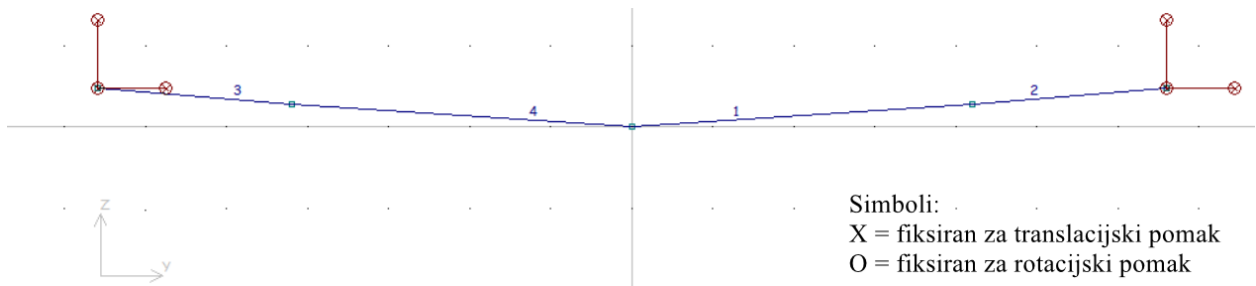

Slika 4.15 Rubni uvjeti modela rebrenice

4.4.3. Dopuštene vrijednosti naprezanja i rezultati

Iz Tablice „Beam Stresses“ na šestoj stranici Dodatka E vidljivo je da su najveća naprezanja smična. Maksimalno smično naprezanje od 72 N/mm^2 u usporedbi s maksimalnim dopuštenim naprezanjima iz Tablice 4.6 potvrđuje prethodnu pretpostavku da su razine naprezanja zadovoljavajuće te da nema potrebe za razvijanjem trodimenzionalnog modela.

Tablica 4.6 Maksimalno dopuštene vrijednosti naprezanja

	$\sigma, \text{ N/mm}^2$	$\sigma_{\text{ekv}}, \text{ N/mm}^2$	$\tau, \text{ N/mm}^2$
Maksimalno dopuštene vrijednosti naprezanja	150	180	100

Dijagram smičnih sila kod dokovanja te pomak strukture dna uslijed dokovanja prikazani su na slikama niže.

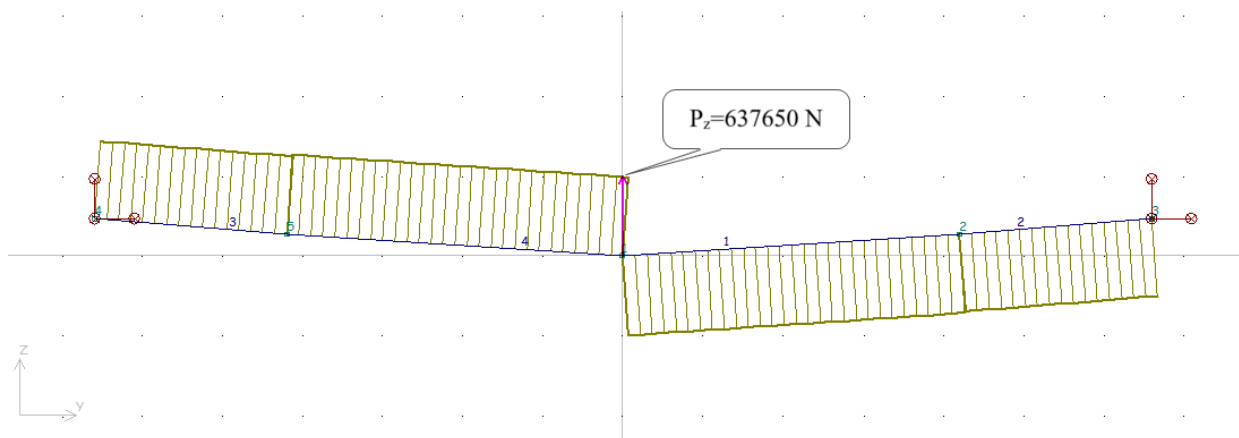

Slika 4.16 Dijagram smičnih sila kod dokovanja

Očekivano, najveći pomak strukture (Slika 4.17) je na sredini tj. u centralnoj liniji broda gdje su potklade i postavljene te iznosi 6,273 mm.

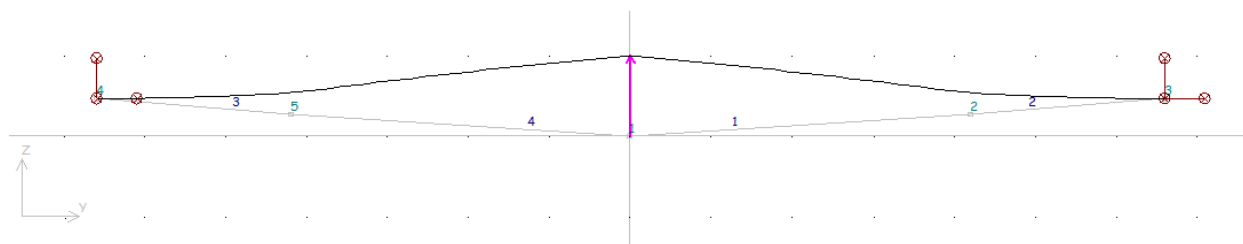

Slika 4.17 Pomak strukture dna uslijed dokovanja

5. PROVJERA STRUKTURE METODOM KONAČNIH ELEMENATA

Danas u inženjerskim proračunima primjena metode konačnih elemenata (MKE) je neizbježna. Zbog mnoštva računskih operacija, analiziranje strukture metodom konačnih elemenata jedino ima smisla obradom u nekom računalnom programu. Shodno tome, postoje brojni računalni programi koji se temelje na ovoj metodi te omogućuju relativno brzu i jednostavnu analizu brodskih konstrukcija. Pri tome nije riječ samo o formiranju i rješavanju matematičkih operacija, već i o prezentaciji rezultata te generiranju podataka. [5]

Kako je metoda konačnih elemenata numerička metoda, dobiveni rezultati nisu egzaktni, već su približni. Drugim riječima, stvarnim vrijednostima moguće se samo približiti uporabom pravilnog proračunskog modela te uz ispravno odabrane tipove konačnih elemenata. Slijedom toga, uz dobro poznavanje teorijske osnove konačnih elemenata, izuzetno je važno i poznavanje fizikalnog ponašanja same konstrukcije koja je predmet analize.

Suvremena metoda provjere dimenzioniranja strukturnih elemenata je izrada modela cijelog ili pojedinih dijelova broda u programskom alatu koji se koristi metodom konačnih elemenata. Ako su parcijalni modeli modelirani ispravno, te ako su precizno oslonjeni i opterećeni, rezultati će biti vrlo blizu rezultatima dobivenim analizom globalnog trodimenzionalnog modela. No, za potrebe izrade detaljnih izvještaja koji se potom šalju na potvrdu klasifikacijskom društvu potrebno je napraviti cijeli model. Za potrebe ovog rada trajekt će biti modeliran djelomično tj. od rebra -36 do rebra 36, no analizirat će se samo raspodjela globalnih uzdužnih naprezanja u paralelnom srednjaku.

Diskretizacija kontinuuma je temelj numerike metode konačnih elemenata. Diskretni model međusobno povezanih elemenata s ograničenim stupnjevima slobode zamjenjuje razmatrani kontinuum s beskonačno stupnjeva slobode gibanja. Razmatrani kontinuum dijeljenjem na konačan broj potpodručja postaje mreža konačnih elemenata. Što je mreža gušća ili drugim riječima što je broj konačnih elemenata veći, rješenje je točnije. Karakteristične veličine prvo se izračunavaju lokalno tj. zasebno u svakom konačnom elementu te potom se odgovarajućim transformacijama mogu izračunati globalno za čitavu konstrukciju.

Rad programskih alata koji se temelje na metodi konačnih elemenata možemo podijeliti u tri radne faze, a to su prethodna obrada (eng. pre-processing), simulacija (eng. processing) te naknadna obrada (eng. post-processing). Kao alat za pre-processing korišten je program GeniE, alat za processing Sestra te kao alat za post-processing korišten program Xtract.

Programski modul Sestra (eng. Superelement Structural Analysis) koristi metodu konačnih elemenata za linearnu strukturnu analizu. Prethodno izrađeni model u GeniE-u upotrebljava kao ulazni podatak i generira matricu krutosti koju potom rješava.

Metoda konačnih elemenata zapravo služi kao alat za potvrdu pretpostavki. Cilj je provjeriti raspodjelu globalnih uzdužnih naprezanja paralelnog srednjaka uslijed uzdužnog opterećenja momenata primjenom metode konačnih elemenata. Nadalje, metodom konačnih elemenata potvrdit će se pretpostavka efektivnih strukturnih elemenata u uzdužnoj čvrstoći broskog trupa te će se posljedično provjeriti čvrstoća djelomično uključenih strukturnih elemenata u uzdužnoj čvrstoći broda.

5.1. Izrada modela

Model trajekta izrađen u GeniE programskom paketu prikazan je na Slici 5.1, a modeliran je prema prethodno proračunatim strukturnim dimenzijama iz trećeg poglavlja ovog rada tj. prema nacrtu glavnog rebra iz Dodatka B.

Model je smješten u radni prostor programa prema standardnoj brodograđevnoj praksi. Ishodište koordinatnog sustava nalazi se u sjecištu osnovice s centralnom ravninom. Os x definirana je u uzdužnom smjeru, pozitivne orijentacije prema pramcu. Os y definirana je u poprečnom smjeru, pozitivnog usmjerenja prema lijevom boku. Globalna os z definirana je u vertikalnom smjeru s pozitivnim smjerom od osnovice prema nadgrađu broda. Na slici modela trajekta prikazan je koordinatni sustav koji u ovom slučaju nije postavljen u ishodištu, no može koristiti za bolje razumijevanje orijentacije istog.

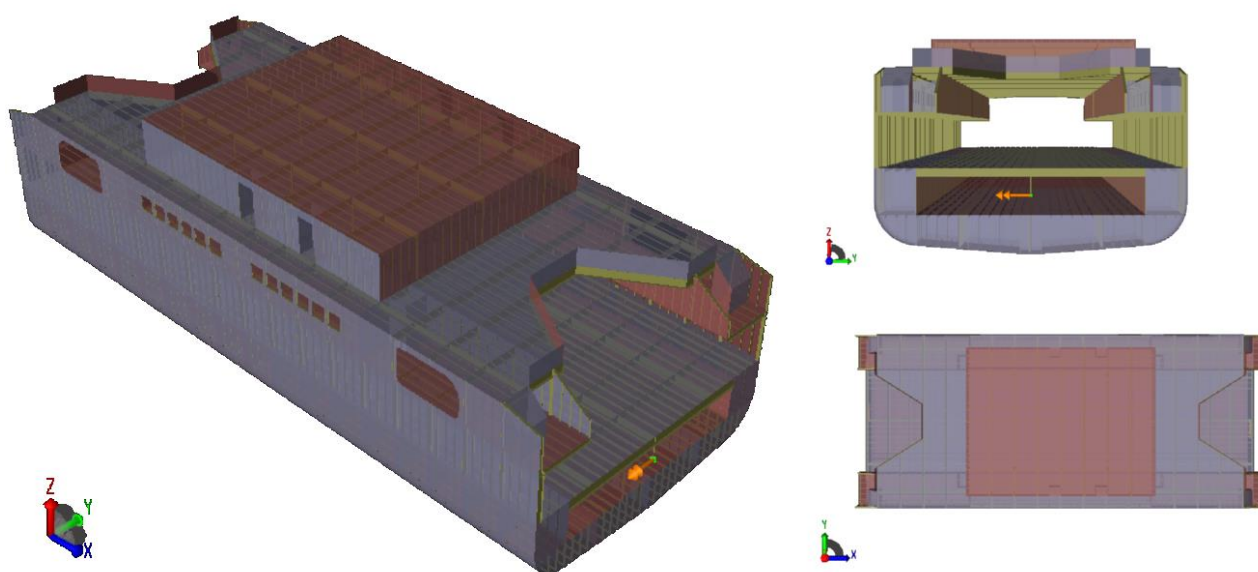

Slika 5.1 Model trajekta izrađen u GeniE programskom paketu

Struktura uključena u model obuhvaća glavne konstruktivne elemente kao što su opločenja paluba, kobilica, hrptenica, podveze, bočni nosači, poprečna bočna rebra, rebrenice u dvodnu i transverze, te sekundarne strukturne elemente kao što su uzdužnjaci dvodna, glavne i gornjih paluba.

Dvije korištene vrste materijala su obični brodograđevni čelik te brodograđevni čelik povišene čvrstoće (Tablica 5.1).

Tablica 5.1 Karakteristike upotrjebljenih materijala

Brodograđevni čelik	Granica razvlačenja	Gustoća	Young-ov modul elastičnosti materijala	Poissonov koeficijent
	R_{eH} , MPa	t/mm^3	E, MPa	ν
Običan	235	$7,85 \cdot 10^{-9}$	210000	0,3
Povišene čvrstoće	355	$7,85 \cdot 10^{-9}$	210000	0,3

5.2. Rubni uvjeti i opterećenje

Rubni uvjeti uzeti su prema ShipRight procedurama iz Lloyd Registra te su prikazani u Tablici 5.2 i na Slici 5.2. U svrhu minimiziranja utjecaja rubnih uvjeta na odziv konstrukcije, oslonci su postavljeni u sjecištima jakih strukturnih elemenata. Iz tog razloga su poprečna tj. transverzalna ograničenja postavljena na poprečne pregrade na rebrima +12 i -12 te na samim krajevima modela (Slika 5.3 i Slika 5.4).

Tablica 5.2 Rubni uvjeti za globalna naprezanja na savijanje [6]

Pozicija	Translacija			Rotacija		
	δ_x	δ_y	δ_z	θ_x	θ_y	θ_z
Ograničenja na krajevima modela						
Krmeni kraj	L	-	-	-	L	L
Pramčani kraj	L	-	-	-	L	L
Neovisna točka na krmenom kraju	●	■	■	■	M	●
Neovisna točka na pramčanom kraju	-	■	■	■	M	●
Poprečna (transverzalna) ograničenja						
Točke K,L	-	●	-	-	-	-
Vertikalna ograničenja						
Točke G, H, I, J	-	-	●	-	-	-

Simboli

- ograničeno (fiksno)
- ograničenje (fiksno) može biti potrebno za uklanjanje matematičkih singularnosti
- nema ograničenja (slobodno)
- L kruto povezano s neovisnom točkom na neutralnoj osi u središnjoj liniji
- M primijenjen moment savijanja na neovisnu točku

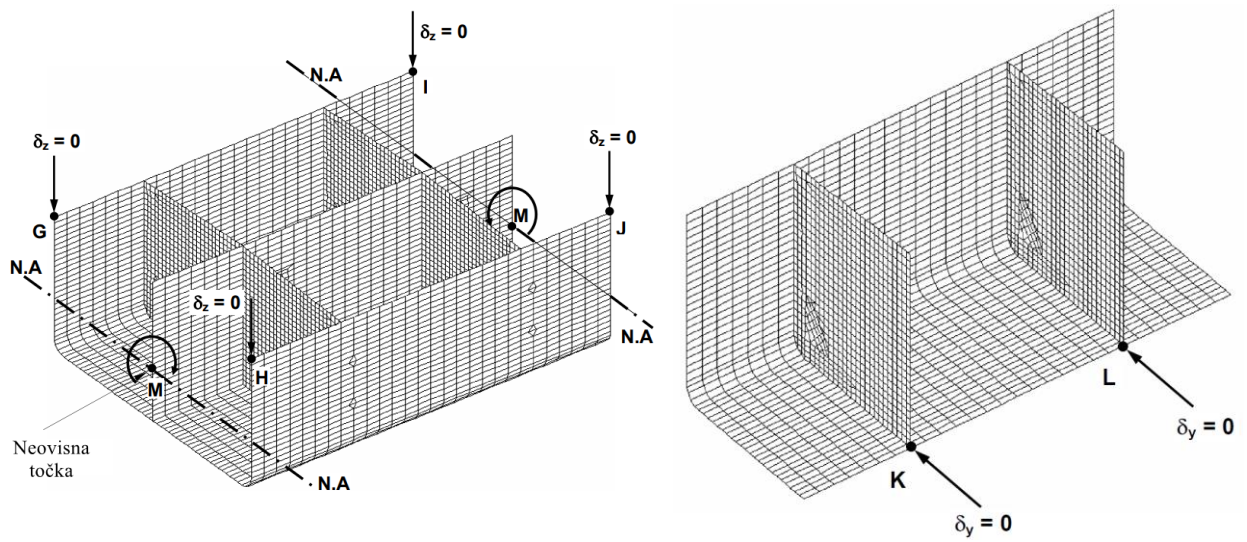

Slika 5.2 Rubni uvjeti MKE modela prema Lloyd Registru [6]

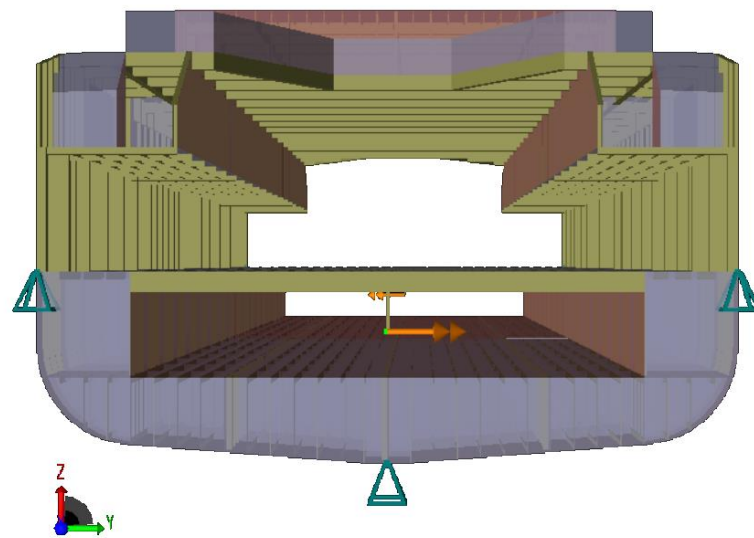

Slika 5.3 Rubni uvjeti MKE modela; pogled s pramca

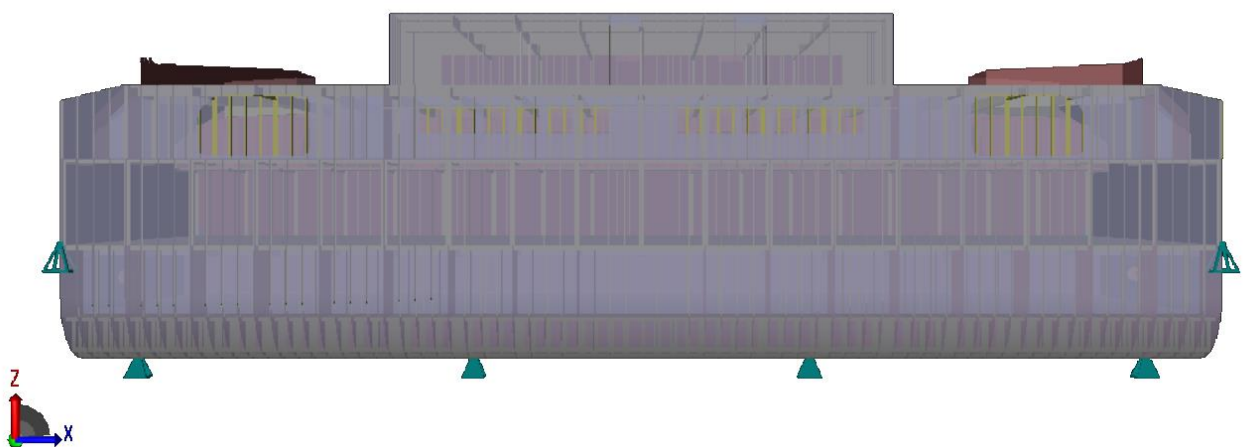

Slika 5.4 Rubni uvjeti MKE modela; pogled s boka

Na model trajekta primijenjena su dva slučaja opterećenja:

- LC 1 - brod u pregibu (eng. hogging)
- LC 2 - brod u progibu (eng. sagging)

Za potrebe nanošenja slučajeva opterećenja za stanje pregiba i progiba potrebno je dobiti ukupni moment savijanja za svako stanje. Ukupan pregibni moment savijanja jednak je zbroju pregibnog momenta savijanja na mirnoj vodi ($M_{BH\ SW}$) i pregibnog momenta savijanja na valovitoj vodi (M_{WH}). Analogno tome, ukupan progibni moment savijanja jednak je zbroju progibnog momenta savijanja na mirnoj vodi ($M_{BS\ SW}$) i progibnog momenta savijanja na valovitoj vodi (M_{WS}). Stoga, konačni slučajevi opterećenja MKE modela za stanja pregiba i progiba prikazani su u Tablici 5.3.

Tablica 5.3 Slučajevi opterećenja MKE modela

		Koordinate, mm			m_y , N/mm
		x	y	z	
LC1	brod u pregibu	21600	0	3374	$9,899 \cdot 10^{10}$
		-21600	0	3374	$-9,899 \cdot 10^{10}$
LC2	brod u progibu	21600	0	3374	$-1,1115 \cdot 10^{11}$
		-21600	0	3374	$1,1115 \cdot 10^{11}$

Jedna od karakteristika protočnih trajekata je da su uvijek u stanju pregiba na mirnoj vodi, a uzrok tome je prilično ravnomjerna raspodjela vlastite težine po dužini broda te oblik. Odnosno imaju višak uzgona u sredini te višak težine na krajevima broda. Posljedica takve raspodjele statičkog opterećenja obično je opterećenost vrlo velikim momentom savijanja na mirnoj vodi. Upravo kombinacija najvećeg momenta savijanja na mirnoj vodi i najvećeg momenta savijanja na valovima daje najveća uzdužna naprezanja.

S druge strane, varijanta najmanjeg momenta savijanja na mirnoj vodi i najvećeg momenta savijanja na valovima rezultira pojavom tlačnih naprezanja u gornjim palubama što treba izbjegavati. Naime, kako je nadgrađe četvrte palube izrađeno od tankih ploča debljine 7 mm, njihovu strukturu treba provjeriti na izvijanje.

Mreža je generirana automatski. Kao preferenca pri izradi mreže izabrani su kvadratni elementi. Odabrana duljina elemenata mreže iznosi 300 mm radi matematičke pogodnosti s rebrenim razmacima koji su 600 mm te se pokazala kao prikladni izbor.

5.3. Rezultati metode konačnih elemenata

Nakon modeliranja, nanošenja dva slučaja opterećenja i definiranja rubnih uvjeta provedena je linearno statička analiza. Xtract je dio programskog paketa Sesam koji služi za vizualnu prezentaciju rezultata, animaciju te za izradu izvješća o rezultatima.

Iako je u programu GeniE trajekt modeliran od rebra -36 do rebra 36, u programu Xtract analizirat će se samo naprezanja u području paralelnog srednjaka tj. područje od rebra -18 do rebra 18 kako bi se izbjegla područja blizu utjecaja rubnih uvjeta, gdje bi rezultati bili nerealni.

Dijelove strukture moguće je složiti u skupine tj. setove te na taj način osim analize globalnog modela, moguće je provjeriti naprezanja samo u određenoj skupini elemenata, primjerice glavna paluba, nadgrađe, oplata i sl. Također, raspon ljestvice naprezanja moguće je podesiti prema željenom opsegu. U ovom slučaju podešeno je da tople boje (crvena, narančasta i žuta) prikazuju pozitivna naprezanja, dok hladne boje (različite nijanse plave) prikazuju negativna naprezanja. Kao atribut prikaza rezultata izabran je tzv. D-STRESS koji sadrži raščlanjena naprezanja. Točnije, analizirana su SIGMX (σ_{Mx}) naprezanja u smjeru lokalne x-osi.

5.3.1. Pregibno stanje

U pregibnom stanju broda vlačna naprezanja se pojavljuju na palubi, dok se u dnu pojavljuju tlačna naprezanja.

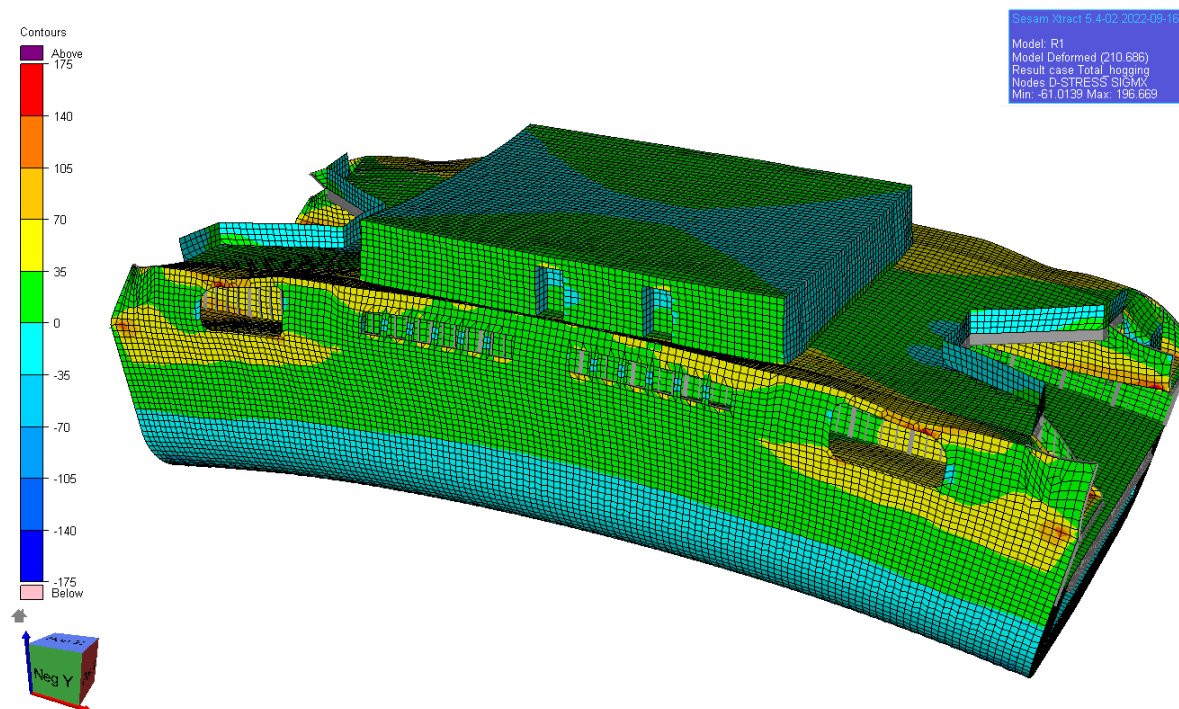

Slika 5.5 Naprezanja σ_x MKE modela u stanju pregiba

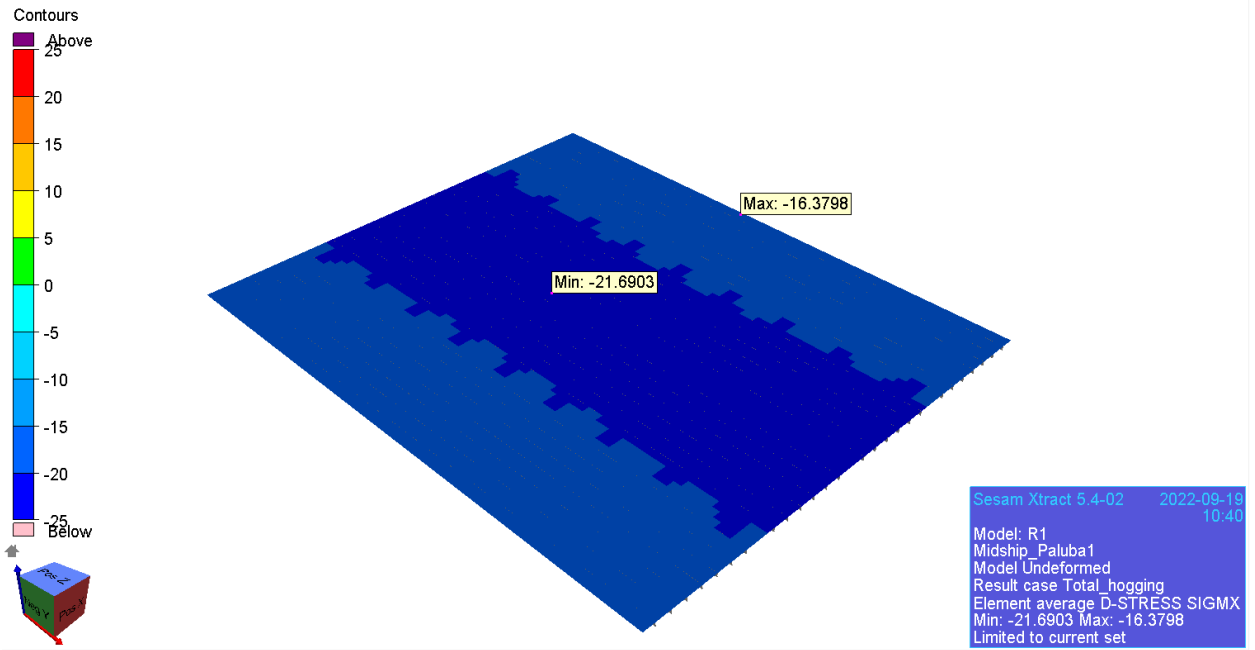

Slika 5.6 Naprezanja σ_x u paralelnom srednjaku Palube 1 u stanju pregiba

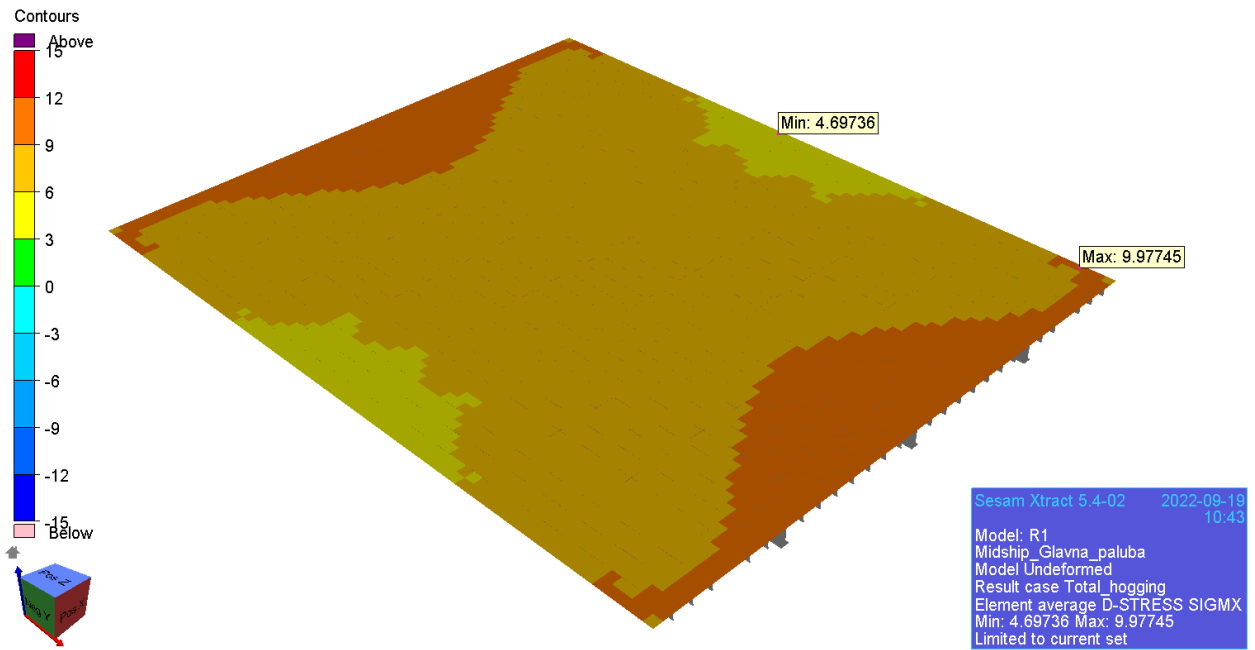

Slika 5.7 Naprezanja σ_x u paralelnom srednjaku glavne palube (Paluba 2) u stanju pregiba

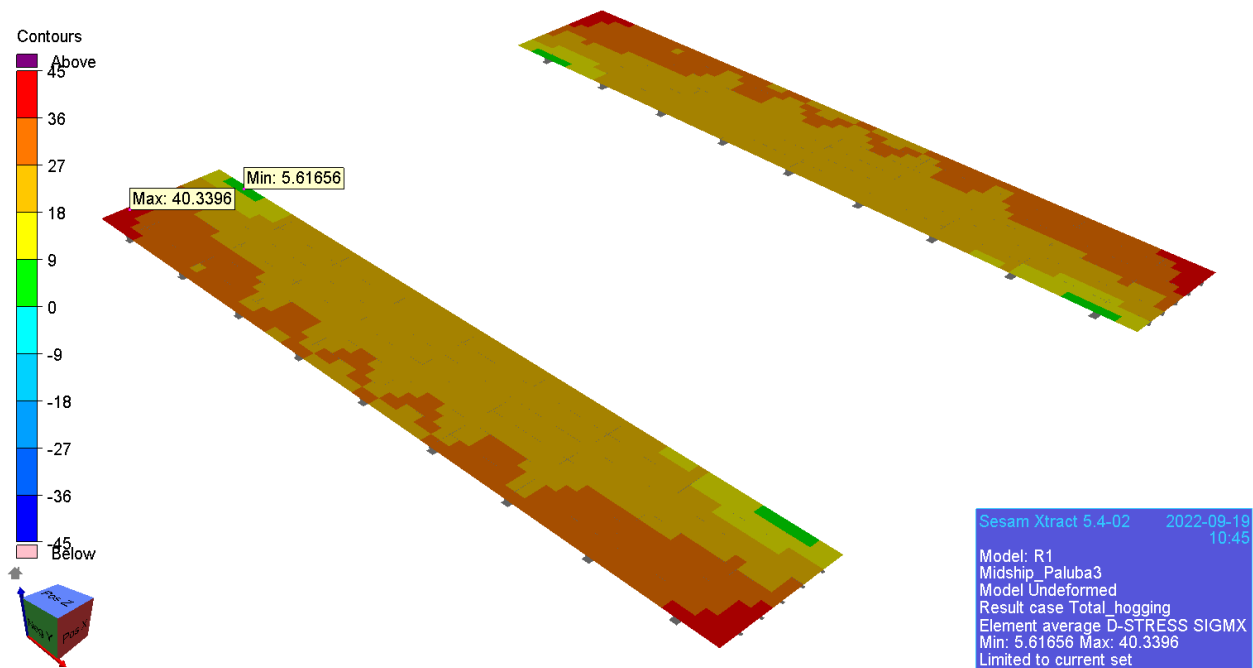

Slika 5.8 Naprezanja σ_x u paralelnom srednjaku palube čvrstoće (Paluba 3) u stanju pregiba

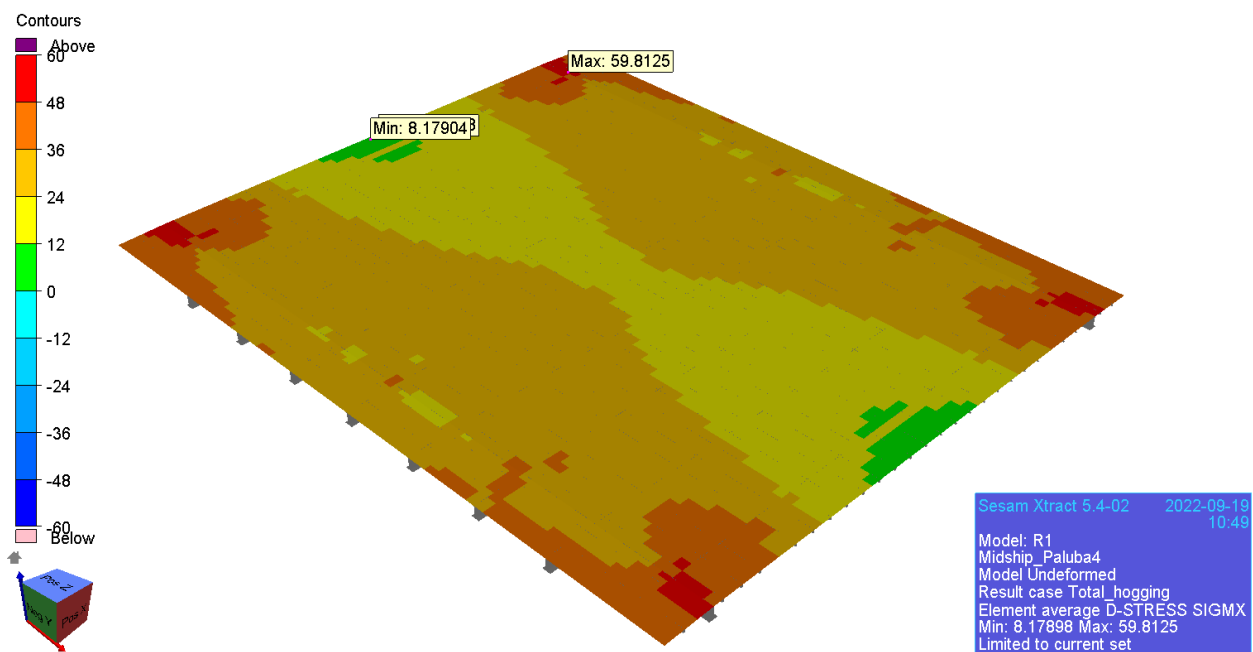

Slika 5.9 Naprezanja σ_x u paralelnom srednjaku Palube 4 u stanju pregiba

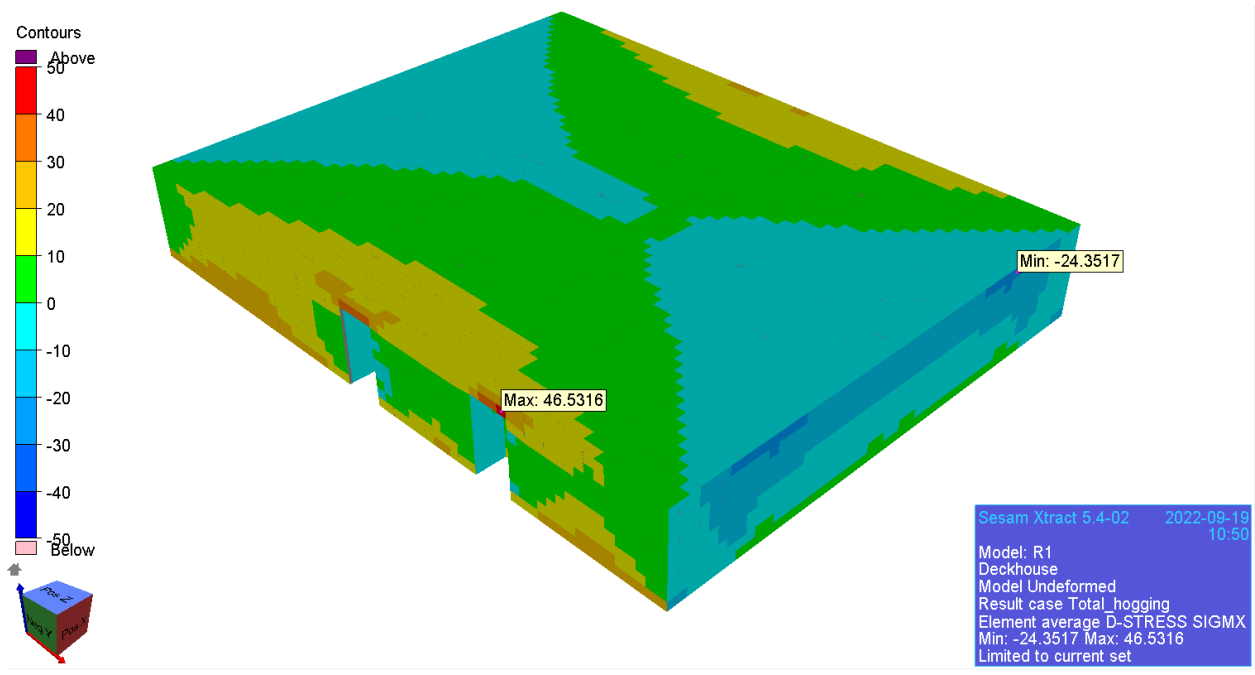

Slika 5.10 Naprezanja σ_x u nadgrađu u stanju pregiba

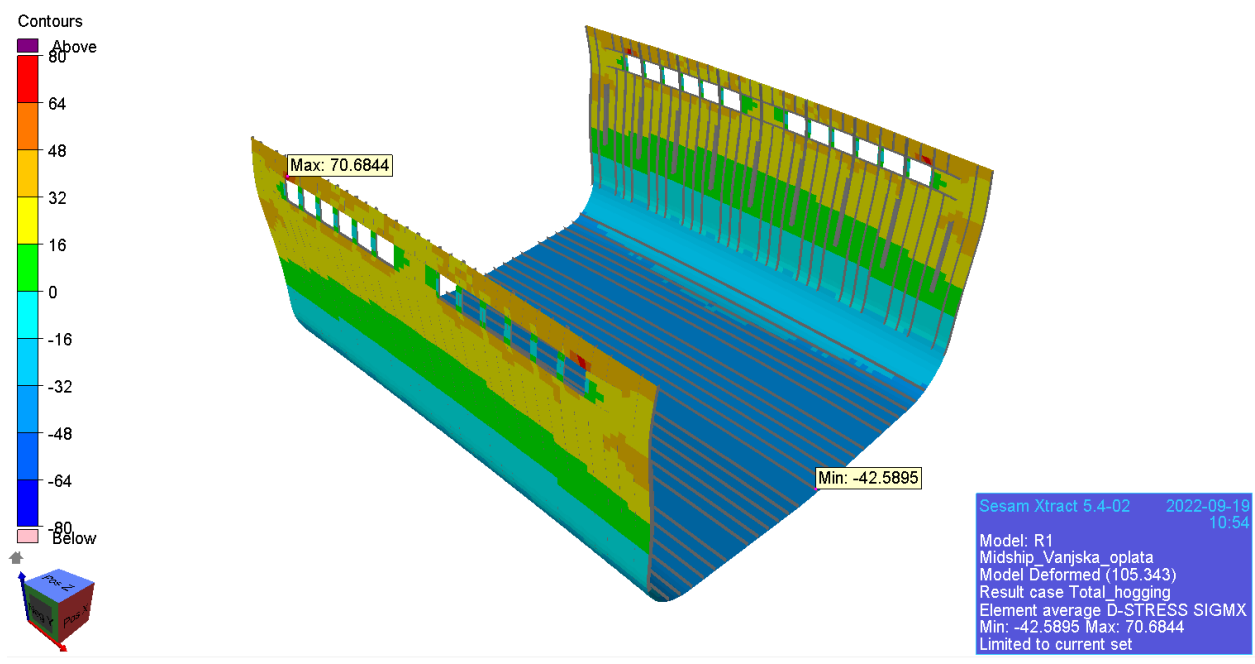

Slika 5.11 Naprezanja σ_x oplate paralelnog srednjaka u stanju pregiba

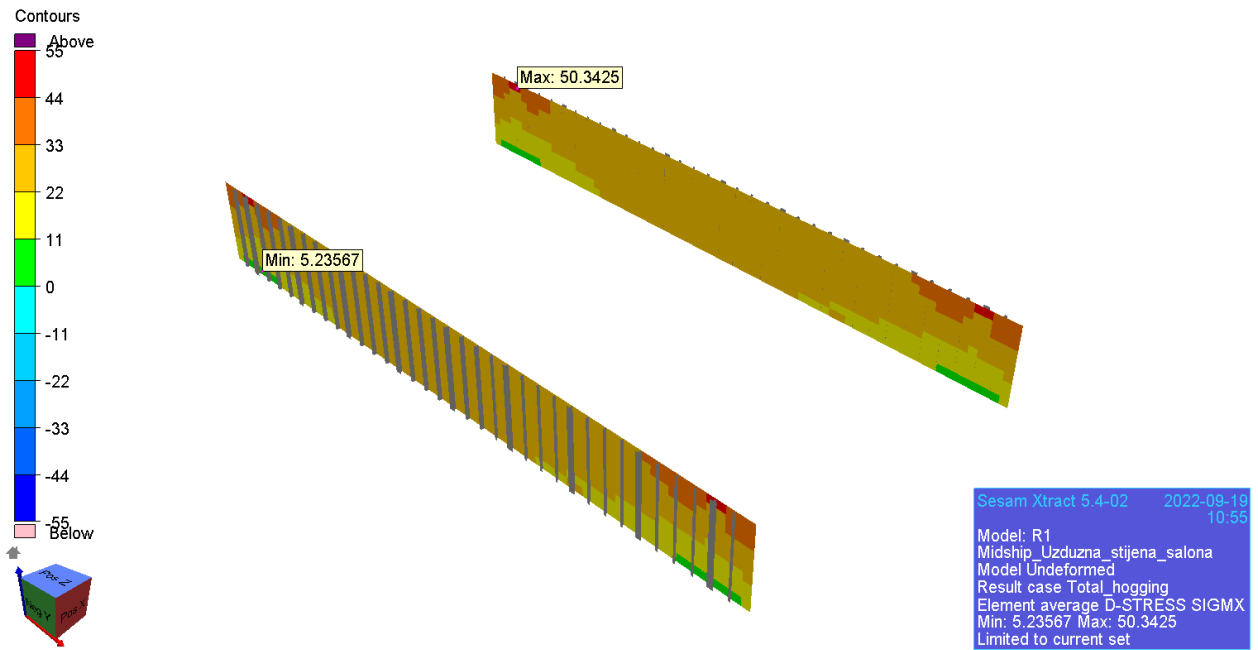

Slika 5.12 Naprezanja σ_x uzdužne stijene salona na Palubi 3 u stanju pregiba

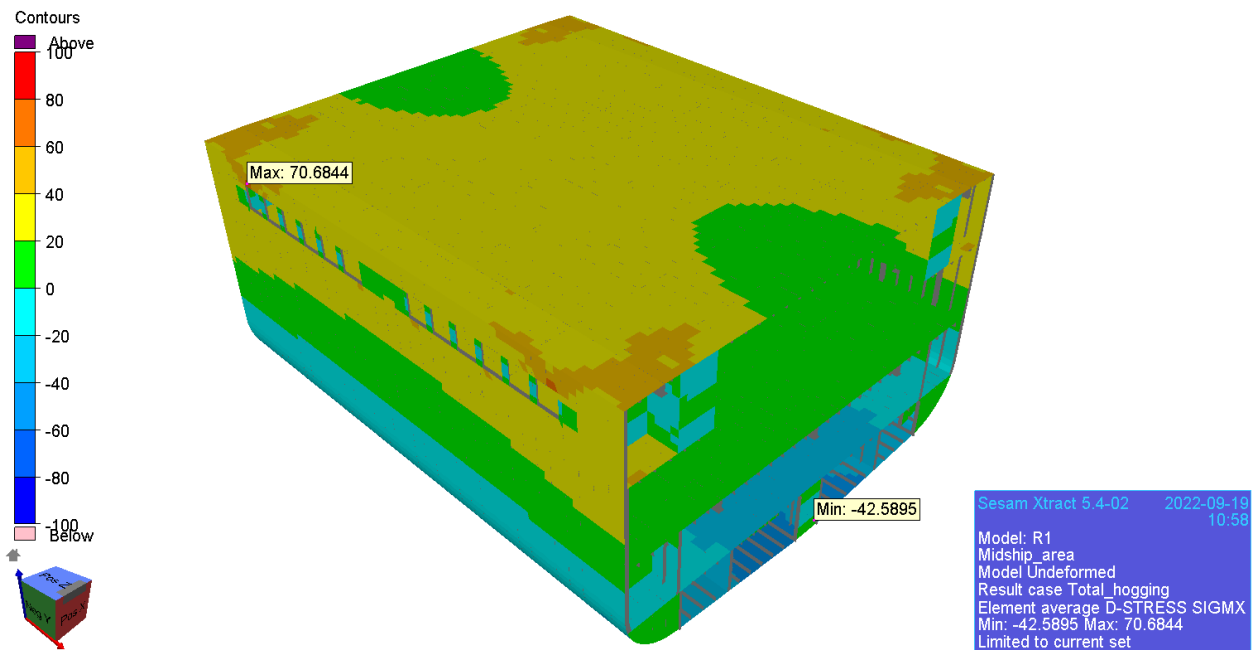

Slika 5.13 Naprezanja σ_x u paralelnom srednjaku u stanju pregiba - pogled odozgo

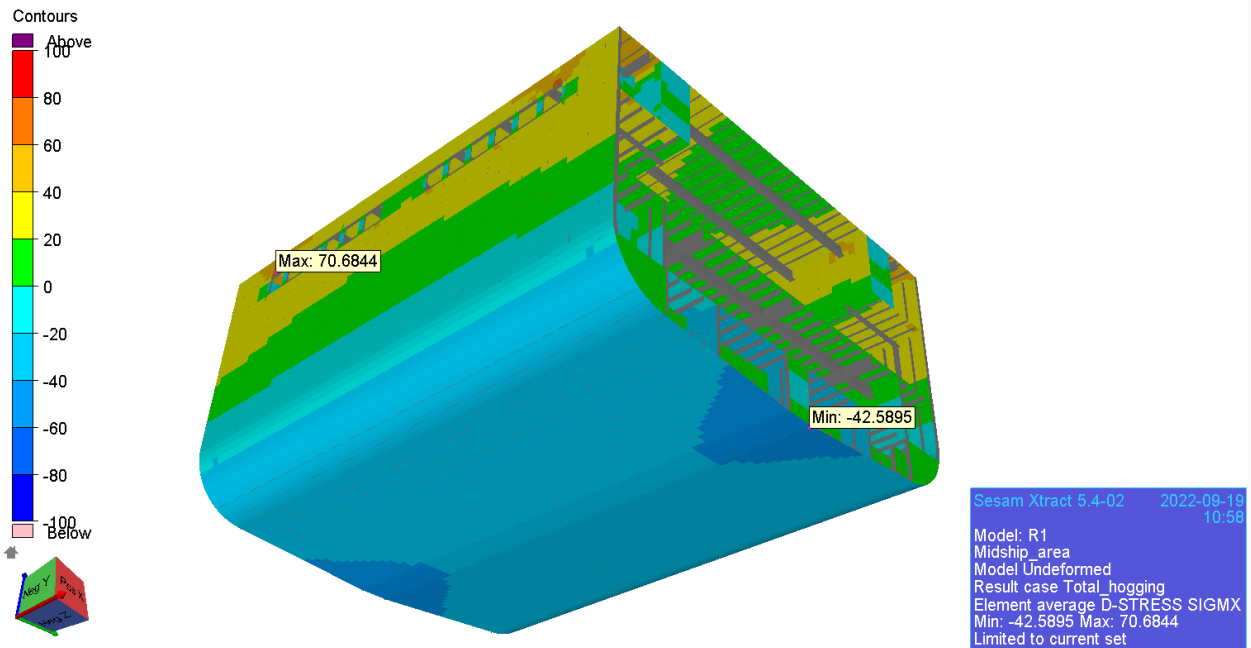

Slika 5.14 Naprezanja σ_x u paralelnom srednjaku u stanju pregiba - pogled odozdo

5.3.2. Progibno stanje

S druge strane, kod progibnog stanja broda na palubi se pojavljuju tlačna naprezanja, a u dnu vlačna naprezanja.

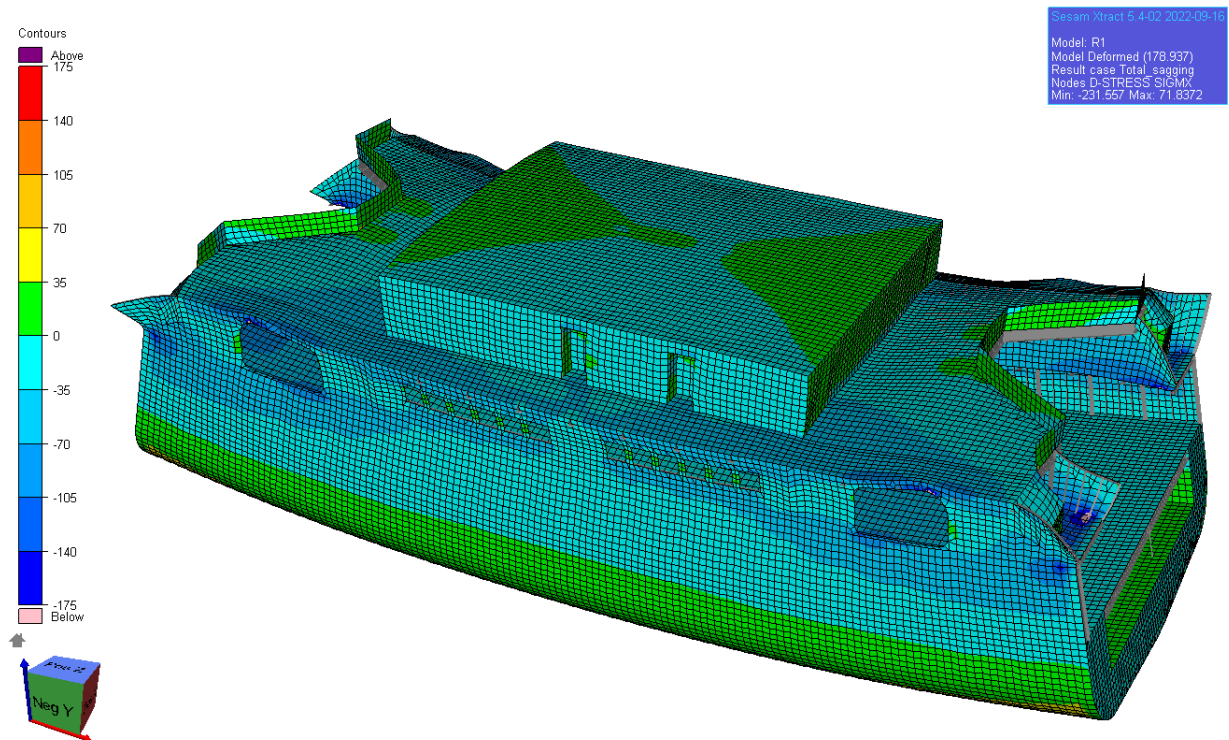

Slika 5.15 Naprezanja σ_x MKE modela u stanju progiba

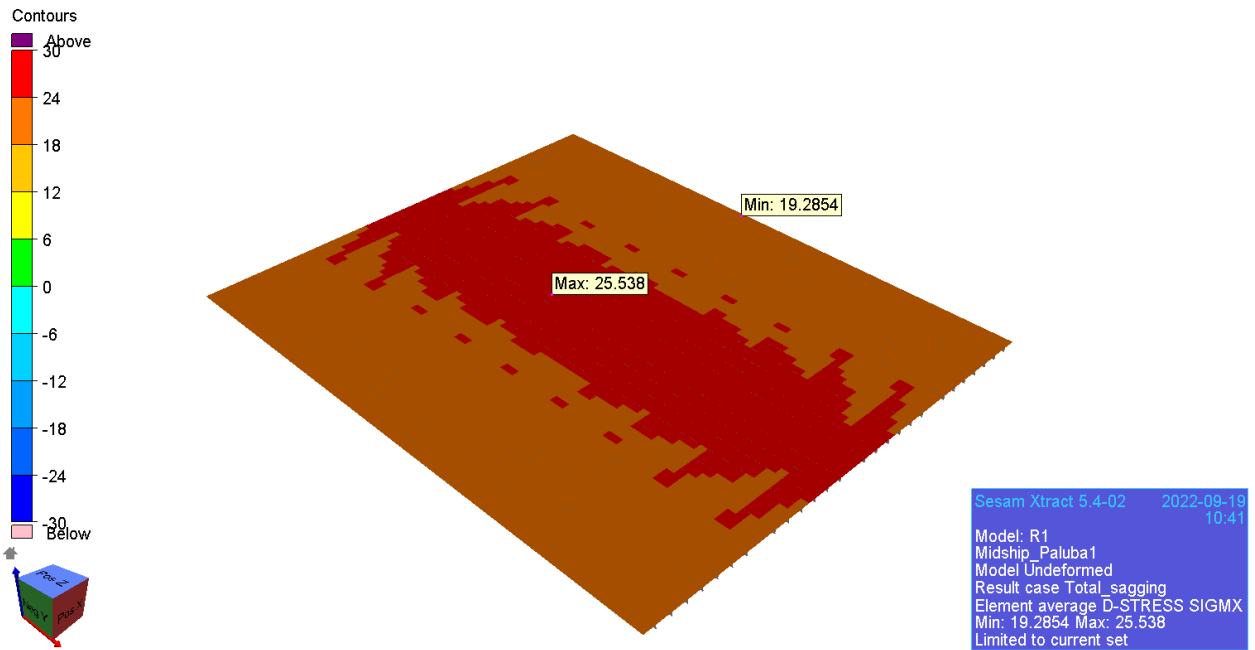

Slika 5.16 Naprezanja σ_x u paralelnom srednjaku Palube 1 u stanju progiba

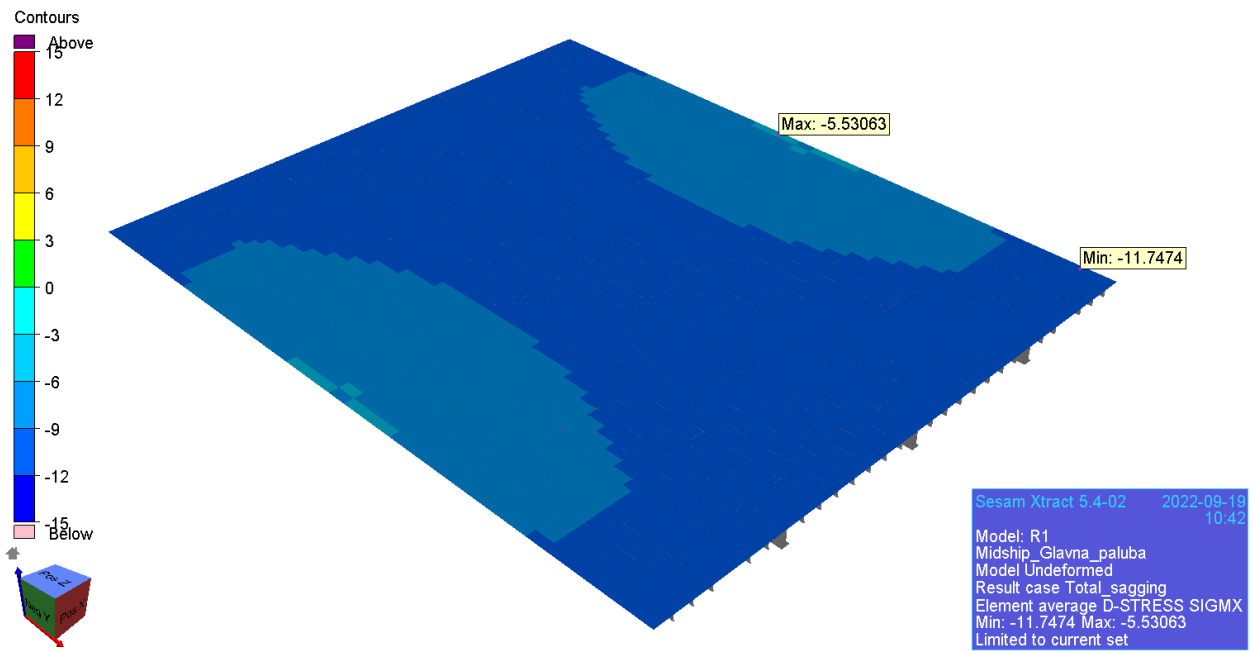

Slika 5.17 Naprezanja σ_x u paralelnom srednjaku glavne palube (Paluba 2) u stanju progiba

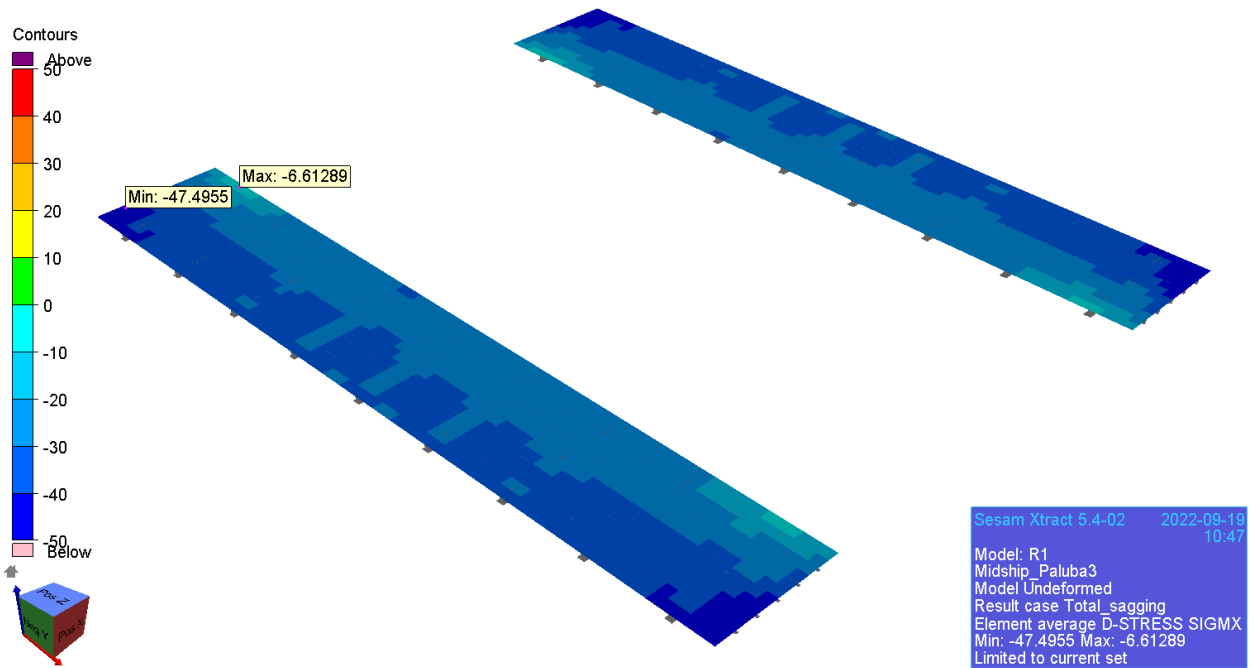

Slika 5.18 Naprezanja σ_x u paralelnom srednjaku palube čvrstoće (Paluba 3) u stanju progiba

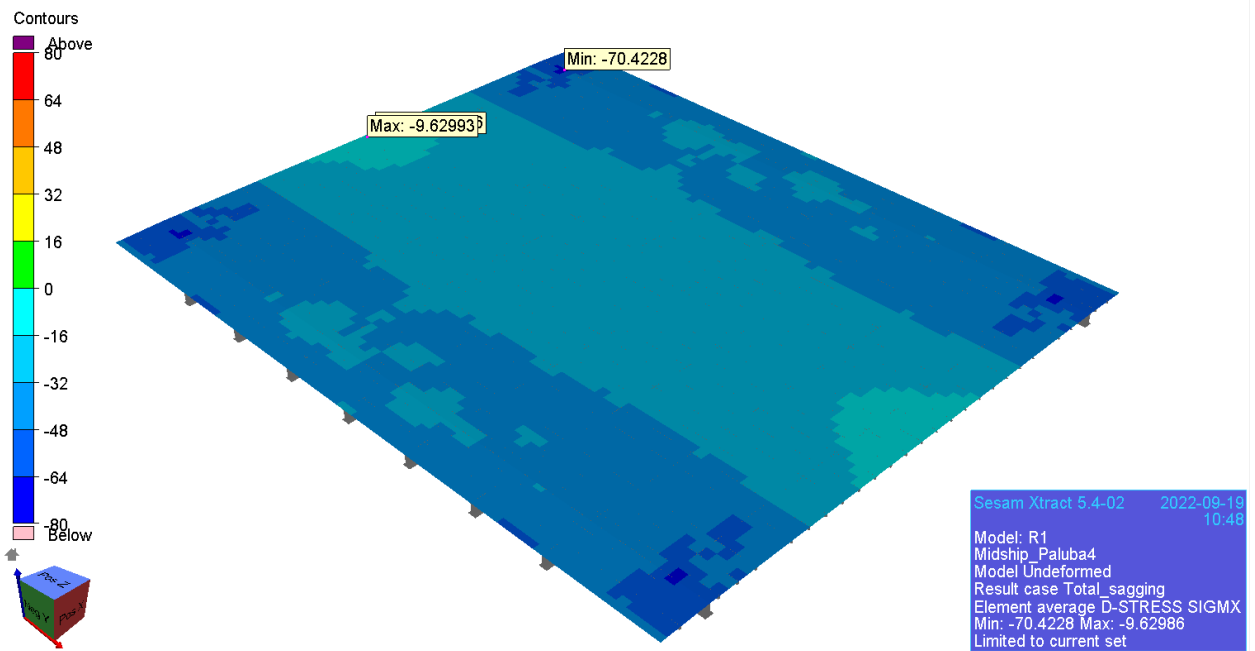

Slika 5.19 Naprezanja σ_x u paralelnom srednjaku Palube 4 u stanju progiba

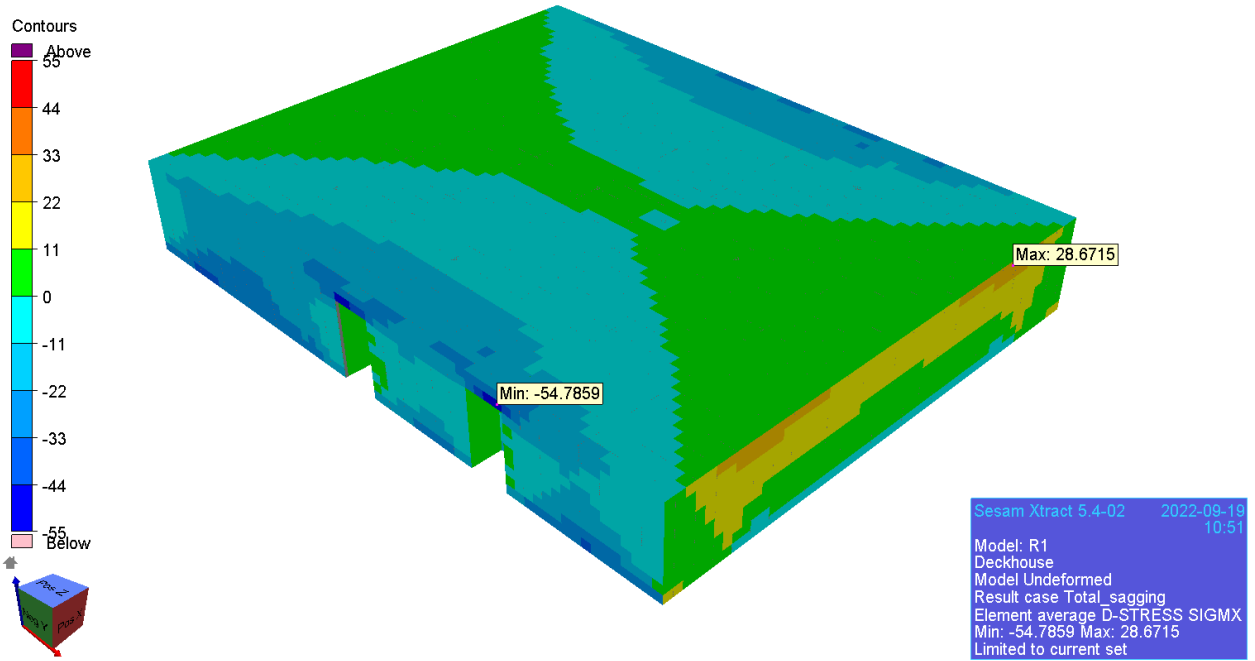

Slika 5.20 Naprezanja σ_x u nadgrađu u stanju progiba

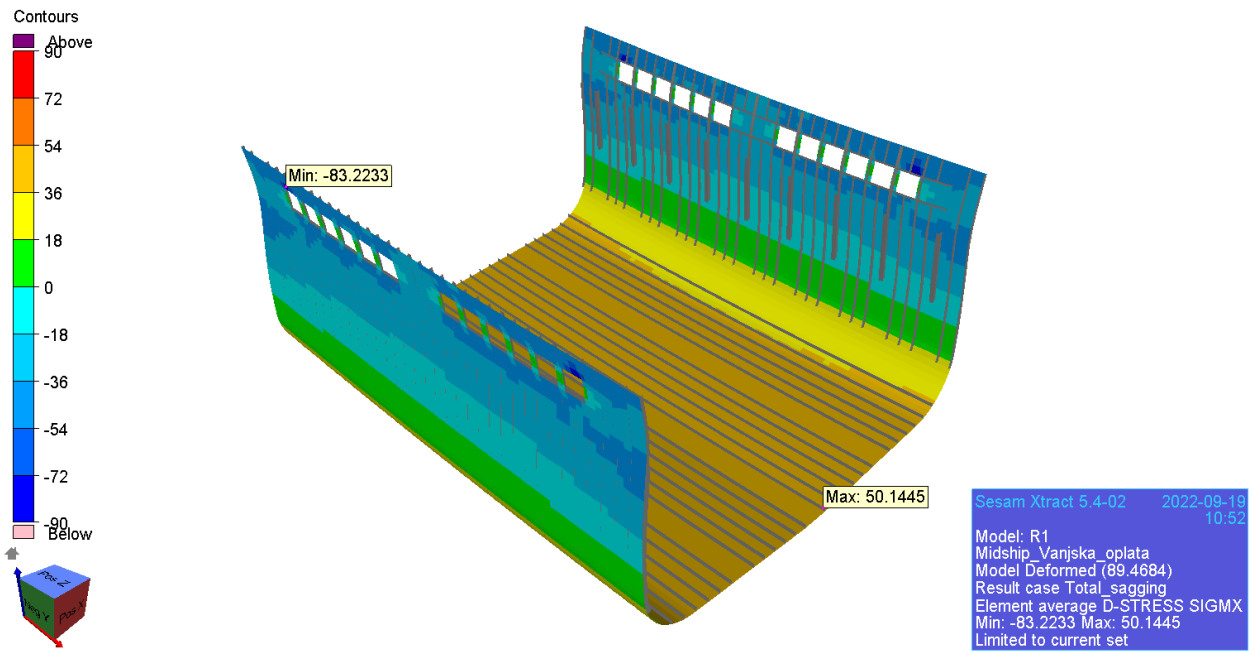

Slika 5.21 Naprezanja σ_x oplate paralelnog srednjaka u stanju progiba

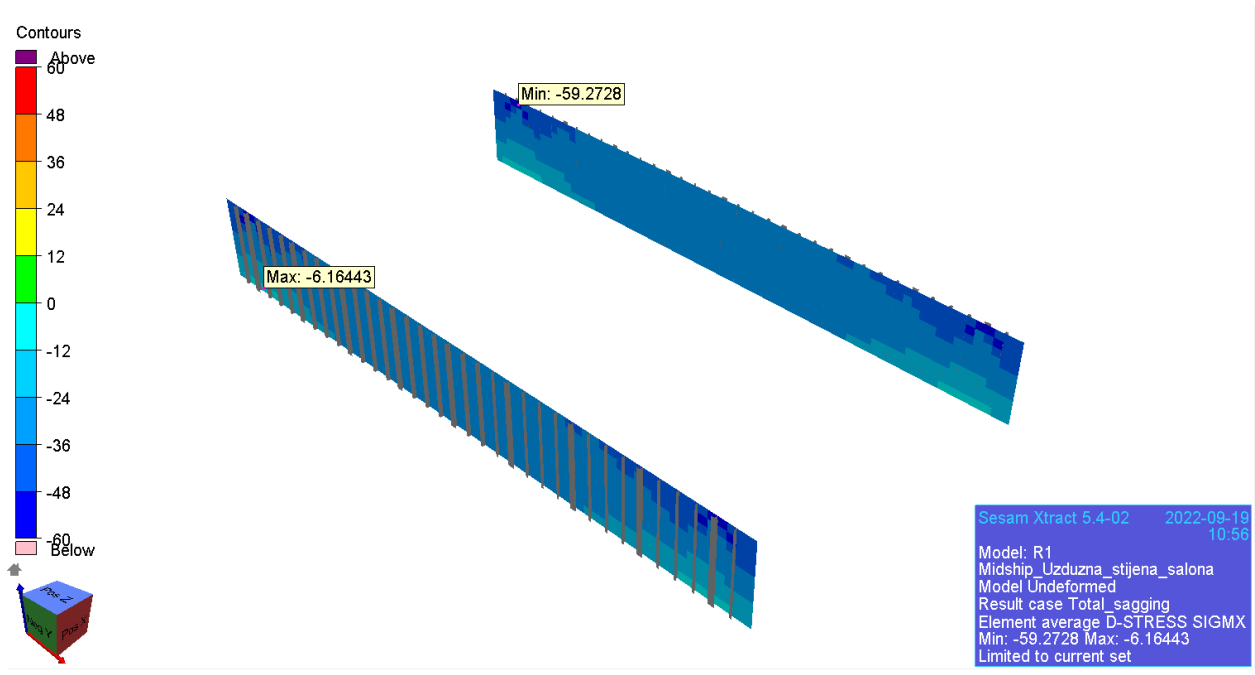

Slika 5.22 Naprezanja σ_x uzdužne stijene salona na Palubi 3 u stanju progiba

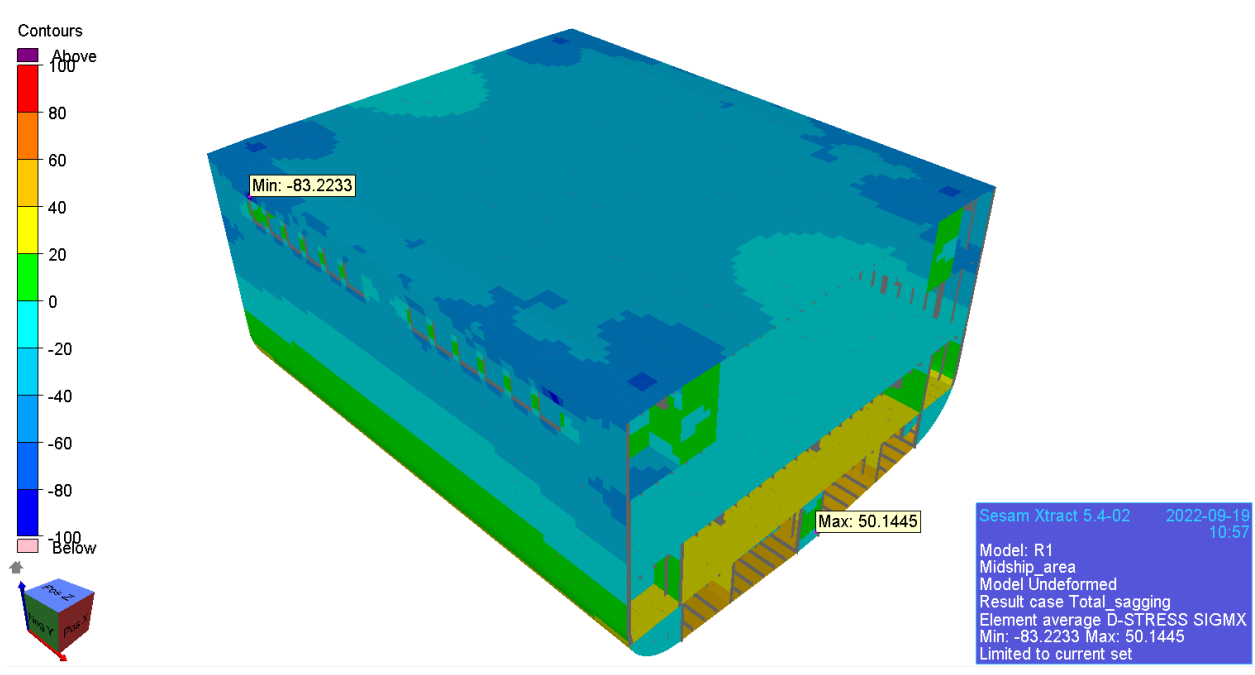

Slika 5.23 Naprezanja σ_x u paralelnom srednjaku u stanju progiba - pogled odozgo

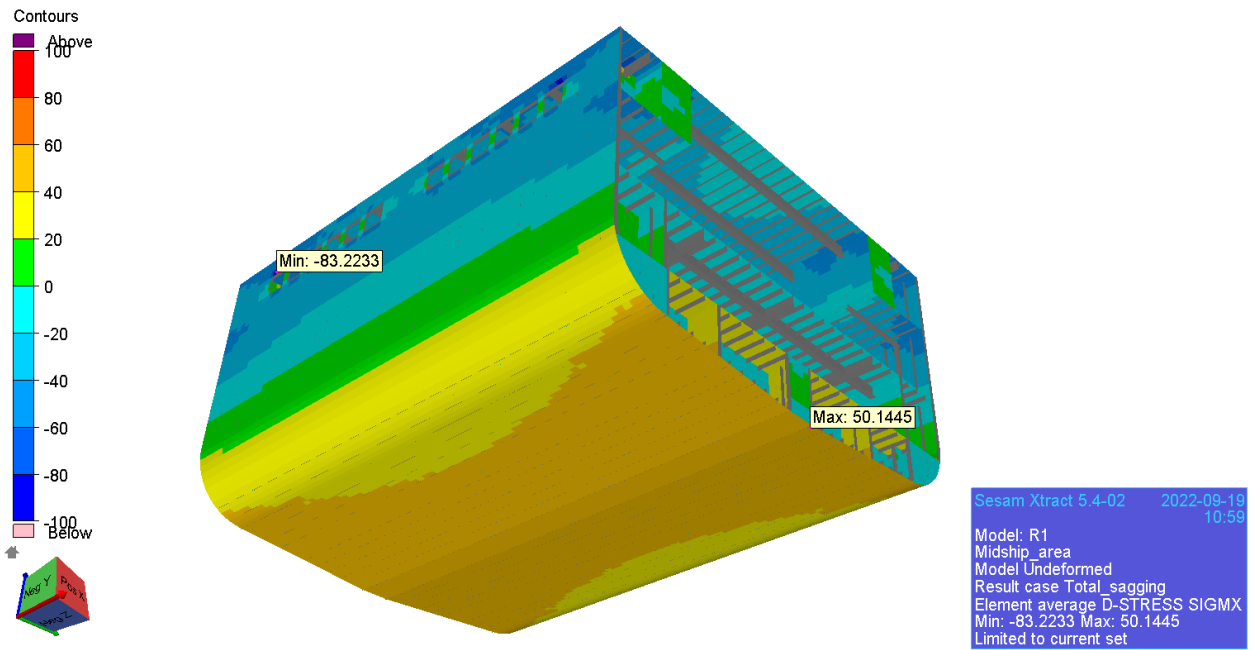

Slika 5.24 Naprezanja σ_x u paralelnom srednjaku u stanju progiba - pogled odozdo

5.3.3. Provjera uključenosti brodske strukture u uzdužnu čvrstoću broda

MKE analiza broskog trupa dokazuje djelomičnu uključenost brodske strukture i iznad Palube 3 koja je inicijalno proglašena palubom čvrstoće. Iz tog razloga potrebno je provjeriti strukturnu stabilnost iste uslijed maksimalnog uzdužnog momenta a kako bi se izbjegla pojava elastičnog izvijanja opločenja uslijed maksimalnih opterećenja. Slijedom toga, iterativnom metodom faktoriziranja uključenosti strukture iznad palube čvrstoće dolazimo do zaključka da je uzdužna pregrada salona te vanjske oplata iznad Palube 3 uključena 55% u uzdužnu čvrstoću. Isti faktor uključenosti vrijedi i za Palubu 4. Faktor uključenosti određen je kalibracijom naprezanja proizašlih iz karakteristika poprečnog presjeka izračunatih kroz Nauticus Hull s rezultatnim naprezanjima proizašlih iz analize metodom konačnih elemenata.

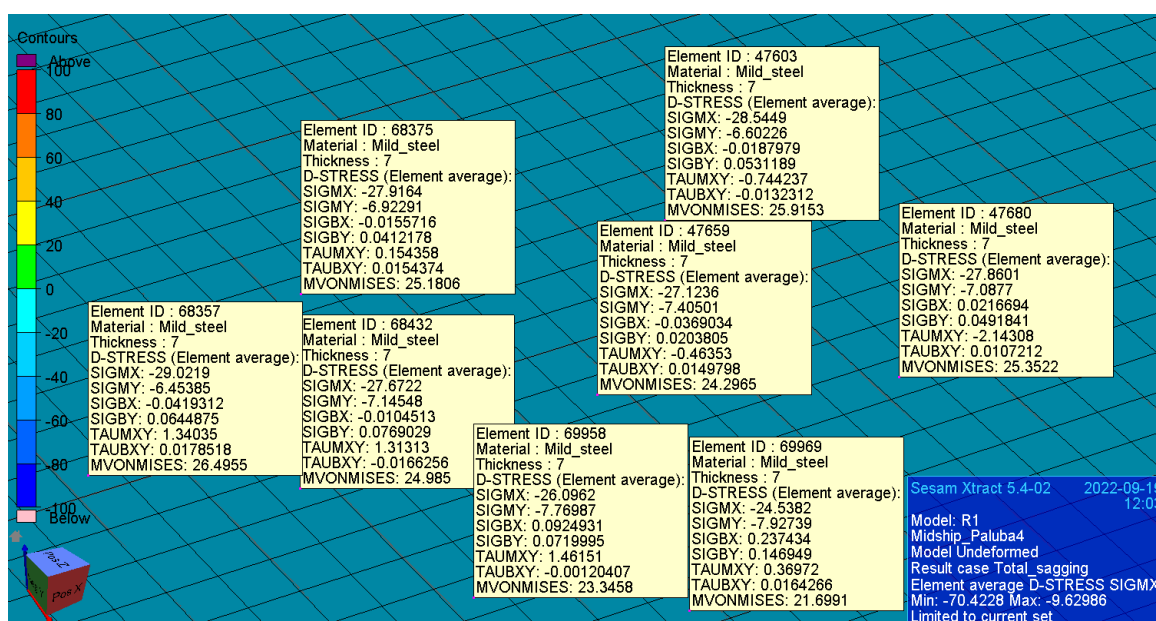

Slika 5.25 Naprezanja Palube 4

Na slici 5.25 prikazana su naprezanja Palube 4. Ukoliko se pozornost obrati na vrijednosti označene sa SIGMX vidljivo je da je njihova srednja vrijednost 27,35 N/mm².

Tablica 5.4 Uključenost Palube 4

Vertikalni moment inercije, I_y (bruto, eng. gross)	I	12,89	m ⁴
Vertikalna udaljenost od osnovice do horizontalne neutralne linije	Z_n	4,485	m
Moment savijanja	M_h	98,99	Nm
Naprezanje Palube 4 (10900 mm od osnovice); uključenost 55%	$\sigma_{10,9}$	27,1	N/mm ²
Naprezanje Palube 3 (8100 mm od osnovice)	$\sigma_{8,1}$	27,8	N/mm ²
Naprezanje dna	σ_{dno}	34,4	N/mm ²

Promatramo koliko gornja Paluba 4 sudjeluje u globalnom savijanju grede, stoga $\sigma_{10,9}$ određujemo prema izrazu (5.1):

$$\sigma = \frac{M_h(10,9-Z_n)}{I} \cdot 0,55 \quad (5.1)$$

Usporedbom naprezanja za različite postotke uključenosti četvrte palube s naprezanjima dobivenih MKE modelom (Slika 5.25) može se utvrditi da uključenost četvrte palube u uzdužnoj čvrstoći broda iznosi oko 55%. U tom slučaju naprezanje Palube 4 iznosi 27,1 N/mm² (Tablica 5.4) što odgovara srednjoj vrijednosti naprezanja Palube 4 MKE modela.

Kako Paluba 4 ipak djelomično sudjeluje u uzdužnoj čvrstoći, potrebno ju je stabilizirati na izvijanje sukladno Poglavlju 4.6 Hrvatskog registra brodova tj. prema izrazima iz poglavlja 3.9.3. ovog rada. Vrijednosti korištene za proračun prikazane su u Tablici 5.5 i Tablici 5.6.

Tablica 5.5 Izvijanje uzdužno ukrepljenih limova

HRB, Poglavlje 4.6.2.1.1			Paluba 4 (Uključenost 55%)
modul elastičnosti materijala	E	N/mm ²	206000
koeficijent izvijanja	m	-	7,636
smanjena debljina opločenja	t _b	mm	6,50
duljina kraće stranice panela	b	m	1,2
normalno (tlačno) naprezanje	σ_E	N/mm ²	41,54

HRB, Poglavlje 4.6.4.1			Paluba 4 (Uključenost 55%)
moment savijanja broda na mirnoj vodi	M _s	kNm	-29430,00
moment savijanja broda na valu	M _w	kNm	-81720,00
moment inercije glavnog rebra	I _n	cm ⁴	1206900000,0
duljina u vertikalnom smjeru od neutralne osi do promatrane točke	y	m	6,435
koeficijent materijala	k	-	1,00
normalno (tlačno) naprezanje	σ_a	N/mm ²	32,59

ne uzimaju se manje od iznosa dobivenog po izrazu (5.2): $\sigma_a > \frac{30}{k} \quad (5.2)$

			Paluba 4 (Uključenost 55%)
usvojeno normalno (tlačno) naprezanje	σ_a	N/mm ²	32,59
očitanja naprezanja iz MKE modela + 10% margine za sigurnost	σ_c	N/mm ²	31,06

Tablica 5.6 Izvijanje poprečno ukrepljenih limova

HRB, Poglavlje 4.6.2.1.1

			Paluba 4 – Bok (7500 mm od CL)
modul elastičnosti materijala	E	N/mm ²	206000
koeficijent izvijanja	m	-	1,324
smanjena debljina opločenja	t _b	mm	6,50
duljina kraće stranice panela	b	m	0,6
duljina dulje stranice panela	a	m	2,8
koeficijent korekcije	c	-	1,21
normalno (tlačno) naprezanje	σ_E	N/mm ²	28,80

HRB, Poglavlje 4.6.4.1

			Paluba 4 – Bok (7500 mm od CL)
moment savijanja broda na mirnoj vodi	M _s	kNm	-29430,00
moment savijanja broda na valu	M _w	kNm	-81720,00
moment inercije glavnog rebra	I _n	cm ⁴	1206900000,0
duljina u vertikalnom smjeru od neutralne osi do promatrane točke	y	m	6,87
koeficijent materijala	k	-	1,00
normalno (tlačno) naprezanje	σ_a	N/mm ²	34,80

ne uzimaju se manje od iznosa dobivenog po izrazu (5.3): $\sigma_a > \frac{30}{k}$ (5.3.)

			Paluba 4 – Bok (7500 mm od CL)
usvojeno normalno (tlačno) naprezanje	σ_a	N/mm ²	34,80
očitanja naprezanja iz MKE modela + 10% margine za sigurnost	σ_c	N/mm ²	33,42

Na prosjeke očitanih naprezanja iz MKE modela dodana je margina od 10% radi sigurnosti. Očitana naprezanja iz MKE modela za uzdužno ukrepljene limove prikazana su u Tablici 5.7.

Tablica 5.7 Očitana naprezanja iz MKE modela uzdužno ukrepljenih limova

	očitanja naprezanja iz MKE modela + 10% margine za sigurnost
	σ_{MKE}
	N/mm ²
Paluba 1	28,70
Paluba 2	29,04
Paluba 3	32,78
Paluba 4	31,06

Očitana naprezanja iz MKE modela za poprečno ukrepljene limove prikazana su u Tablici 5.8.

Tablica 5.8 Očitana naprezanja iz MKE modela poprečno ukrepljenih limova

	očitanja naprezanja iz MKE modela + 10% margine za sigurnost
	σ_{MKE}
	N/mm ²
Paluba 1 - Uzdužna pregrada 6600 mm od CL	17,12
Paluba 2 – Bok (9000 mm od CL)	18,15
Paluba 3 - Unutarnja rebra salona (Uzdužna pregrada 5400 mm od CL)	31,86
Paluba 3 - Vanjska rebra salona (9000 mm od CL)	35,64
Paluba 4 – Bok (7500 mm od CL)	33,42

Očitana naprezanja σ_{MKE} za uzdužno i poprečno ukrepljene limove svake palube, uključujući i četvrtu palubu, manja su od normalnih tlačnih naprezanja σ_a prethodno izračunatih prema Hrvatskom registru brodova te zaključujemo da su kriteriji za izvijanje zadovoljeni.

5.4. Zaključak MKE analize

Zadaća strukturne analize podobnosti je temeljem izračunatih odziva naprezanja i deformacija prepoznati strukturne elemente koji ne mogu izdržati nametnuta opterećenja. Kako su sva dobivena naprezanja manja od najvećih dozvoljenih, dolazi se do zaključka da su elementi zadovoljavajuće dimenzionirani te da je distribucija naprezanja u paralelnom srednjaku prihvatljiva. Dominantno naprezanje je globalno, a ne lokalno.

Povećana naprezanja su većinom na mjestima gdje se naglo mijenja presjek. Primjerice, vidljivo je povećano naprezanje uz rub prozorskih otvora salona. Zbog toga su rubovi prozora napravljeni sa zaobljenim kutovima kako bi se smanjila koncentracija naprezanja. Drugi primjer povećane koncentracije naprezanja je područje iznad otvora za ulaz u bočnoj stijenci nadgrađa na četvrtoj palubi.

U stanju pregiba, na prvoj palubi, koja se nalazi ispod neutralne linije, javljaju se negativna naprezanja, dok su na gornjim palubama tj. na palubama iznad neutralne linije naprezanja pozitivna. Kod progiba je situacija obrnuta, na prvoj palubi su naprezanja pozitivna, dok su naprezanja paluba iznad neutralne linije negativna.

Prijelazne zone izvan 0,3 L rješavaju se u sljedećoj projektnoj fazi pomoću dodatnih analiza tipičnih poprečnih presjeka. Za svaki tip presjeka potrebno je izraditi zaseban Nauticus Hull model zato što se struktura i moment opterećenja duž broda mijenja, stoga nije ispravno donositi zaključke samo na temelju glavnog rebra.

6. ZAKLJUČAK

Brodovi namijenjeni prijevozu vozila i putnika, od kojih je jedan tema ovog rada, predstavljaju specifičan način prijevoza robe tj. putnika. Čitava brodska konstrukcija podređena je teretu na kotačima. Shodno tome, palube su optimizirane za smještanje što većeg kapaciteta vozila, te se teži strukturnim rješenjima koja ne sputavaju protočnost vozila kroz trajekt.

Proces projektiranja strukture trupa dvostranog trajekta duljine 80 m namijenjenog plovidbi Jadranskim morem u ovom radu je podijeljen kroz tri faze. Prva faza je proračun dimenzija strukturnih elemenata te proračun čvrstoće prema pravilima i propisima Hrvatskog registra brodova. Kako dotičan trajekt ima dvije palube na kojima smješta različite vrste vozila koja točkasto opterećuju palubu, potrebno je dimenzionirati svaku palubnu zasebno na odgovarajuća osovinska opterećenja. Iz tog razloga je debljina paluba različita, za razliku od ostalih teretnih brodova kojima je debljina palubnih limova ujednačena. Osnovni zadatak ove faze bio je zadovoljiti uvjet da otporni moment palube i dna bude veći od minimalnog dopuštenog momenta propisanog Registrom, što je uspješno dokazano.

Potom slijedi proračun i provjera primarnih struktura glavne palube, okvira boka i nadgrađa, te provjera strukture dna uslijed dokovanja. Navedeni segmenti druge faze projektiranja izvedeni su u DNV 3D Beam programskom paketu u kojem se dimenzije automatski provjeravaju u skladu s DNV pravilima, te su također provjerene u skladu s pravilima HRB-a.

Trup broda je trodimenzionalno tijelo oblika tankostjenog kutijastog nosača. Uzdužna čvrstoća je od izrazitog značaja pošto je dimenzija duljine izrazito veća u usporedbi s visinom i širinom. Prilikom analiziranja uzdužne čvrstoće broda, brod se obično promatra kao greda. No, primjenom naprednih programskih paketa koji primjenjuju metodu konačnih elemenata moguće je odrediti uzdužnu čvrstoću vrlo složene strukture broskog trupa. Stoga, je kao treća faza projektiranja primjenom metode konačnih elemenata u jednom od osnovnih alata za strukturnu analizu brodske konstrukcije SESAM (eng. Super Element Structural Analysis Modulus) napravljena provjera distribucije globalnih uzdužnih naprezanja u području paralelnog srednjaka te su dobiveni rezultati zadovoljavajući.

Sljedeća projektna faza bila bi određivanje prijelaznih zona izvan područja 0,3 L tj. dimenzioniranje pramčane i krmene strukture te proračun primarne strukture kormilarnice i protuljuljnog tanka.

LITERATURA

- [1] Uršić, J.: "Čvrstoća broda I. dio", Sveučilišna naklada d.o.o., Zagreb, 1991.
- [2] Watson, D.: "Practical ship design", Elsevier, Oxford, 1998.
- [3] Hrvatski registar brodova: "PRAVILA ZA KLASIFIKACIJU BRODOVA - DIO 2. TRUP", s Interneta, <https://www.crs.hr/hr/pravila-i-aktivnosti-povezani-s-rh/pravila-i-smjernice/pravila-za-klasifikaciju-brodova>, 9. kolovoz 2022.
- [4] Uršić, J.: "Čvrstoća broda II. dio", Sveučilišna naklada d.o.o., Zagreb, 1991.
- [5] Senjanović, I.: "Metode konačnih elemenata u analizi brodskih konstrukcija", Sveučilišna naklada Liber, Zagreb, 1986.
- [6] Lloyd's Register: "ShipRight Primary Structure", s Interneta, [https://www.lr.org/en/shipright-procedures/#accordion-structuraldesignassessment\(sda\)](https://www.lr.org/en/shipright-procedures/#accordion-structuraldesignassessment(sda)), 2. rujan 2022.

POPIS SLIKA

Slika 2.1 Primjeri RO-PAX brodova.....	5
Slika 2.2 Različite izvedbe brodskih rampi.....	7
Slika 2.3 Trajekt Četiri zvonika	8
Slika 2.4 Preliminarni opći plan zadanog broda	9
Slika 3.1 Hrvatski registar brodova.....	10
Slika 3.2 Ilustracija glavnog rebra.....	11
Slika 3.3 Otisak kotača na polju lima.....	15
Slika 3.4 Momenti savijanja.....	21
Slika 3.5 Smična sila	21
Slika 3.6 Koeficijent razdiobe M	22
Slika 3.7 Koeficijenti raspodjele F_1 i F_2	23
Slika 3.8 NauticusHull	23
Slika 3.9 Model u Nauticus Hull.....	24
Slika 4.1 Nauticus 3D Beam programski alat	31
Slika 4.2 3D Beam model primarnih strukturnih elemenata glavne palube.....	32
Slika 4.3 Numeracija čvorova i greda modela glavne palube	32
Slika 4.4 Opterećenja na model.....	33
Slika 4.5 Rubni uvjeti.....	33
Slika 4.6 Pomak strukture glavne palube	35
Slika 4.7 Model okvira boka garažnog prostora	35
Slika 4.8 Prikaz modela okvira boka u xy i xz ravninama.....	36
Slika 4.9 Rubni uvjeti modela okvira boka	36
Slika 4.10 Palubna opterećenja	37
Slika 4.11 Opterećenje od vjetra	38
Slika 4.12 Pomak strukture nakon aplikacije tri slučaja opterećenja.....	39
Slika 4.13 Plan potklada.....	40
Slika 4.14 Rebrenica opterećenja silom dokovanja	41
Slika 4.15 Rubni uvjeti modela rebrenice	42
Slika 4.16 Dijagram smičnih sila kod dokovanja.....	42
Slika 4.17 Pomak strukture dna uslijed dokovanja	43
Slika 5.1 Model trajekta izrađen u GeniE programskom paketu	45
Slika 5.2 Rubni uvjeti MKE modela prema Lloyd Registru [6]	47
Slika 5.3 Rubni uvjeti MKE modela; pogled s pramca.....	47

Slika 5.4 Rubni uvjeti MKE modela; pogled s boka.....	47
Slika 5.5 Naprezanja MKE modela u stanju pregiba	49
Slika 5.6 Naprezanja u paralelnom srednjaku Palube 1 u stanju pregiba	50
Slika 5.7 Naprezanja u paralelnom srednjaku glavne palube (Paluba 2) u stanju pregiba	50
Slika 5.8 Naprezanja u paralelnom srednjaku palube čvrstoće (Paluba 3) u stanju pregiba	51
Slika 5.9 Naprezanja u paralelnom srednjaku Palube 4 u stanju pregiba	51
Slika 5.10 Naprezanja u nadgrađu u stanju pregiba	52
Slika 5.11 Naprezanja oplata paralelnog srednjaka u stanju pregiba	52
Slika 5.12 Naprezanja uzdužne stijene salona na Palubi 3 u stanju pregiba	53
Slika 5.13 Naprezanja u paralelnom srednjaku u stanju pregiba - pogled odozgo	53
Slika 5.14 Naprezanja u paralelnom srednjaku u stanju pregiba - pogled odozdo	54
Slika 5.15 Naprezanja MKE modela u stanju progiba	54
Slika 5.16 Naprezanja u paralelnom srednjaku Palube 1 u stanju progiba	55
Slika 5.17 Naprezanja u paralelnom srednjaku glavne palube (Paluba 2) u stanju progiba	55
Slika 5.18 Naprezanja u paralelnom srednjaku palube čvrstoće (Paluba 3) u stanju progiba.....	56
Slika 5.19 Naprezanja u paralelnom srednjaku Palube 4 u stanju progiba	56
Slika 5.20 Naprezanja u nadgrađu u stanju progiba	57
Slika 5.21 Naprezanja oplata paralelnog srednjaka u stanju progiba.....	57
Slika 5.22 Naprezanja uzdužne stijene salona na Palubi 3 u stanju progiba.....	58
Slika 5.23 Naprezanja u paralelnom srednjaku u stanju progiba - pogled odozgo	58
Slika 5.24 Naprezanja u paralelnom srednjaku u stanju progiba - pogled odozdo	59
Slika 5.25 Naprezanja Palube 4.....	60

POPIS TABLICA

Tablica 2.1 Glavne značajke broda	8
Tablica 3.1 Opterećenja brodske konstrukcije	12
Tablica 3.2 Tlak u kotačima	15
Tablica 3.3 Vrijednosti dopuštenih naprezanja s obzirom na koeficijent materijala	18
Tablica 3.4 Dimenzije okvirnih rebara	18
Tablica 3.5 Dimenzije običnih rebara	18
Tablica 3.6 Moment otpora sponja i uzdužnjaka palube	19
Tablica 3.7 Dimenzije palubnih sponja	19
Tablica 3.8 Dimenzije palubnih uzdužnjaka	19
Tablica 3.9 Momenti savijanja i smične sile na mirnoj vodi	22
Tablica 3.10 Momenti savijanja i smične sile na valovitoj vodi	23
Tablica 3.11 Svojstva presjeka iz programskog paketa NauticusHull	24
Tablica 3.12 Izvijanje uzdužno ukrepljenih limova	27
Tablica 3.13 Izvijanje poprečno ukrepljenih limova	28
Tablica 4.1 Rubni uvjeti modela rešetkaste primarne strukture glavne palube	34
Tablica 4.2 Dopuštene vrijednosti naprezanja brodograđevnog čelika povišene čvrstoće	34
Tablica 4.3 Rubni uvjeti modela okvira boka	36
Tablica 4.4 Proračun linearnih opterećenja vjetra	38
Tablica 4.5 Rubni uvjeti modela prilikom dokovanja	41
Tablica 4.6 Maksimalno dopuštene vrijednosti naprezanja	42
Tablica 5.1 Karakteristike upotrjebljenih materijala	46
Tablica 5.2 Rubni uvjeti za globalna naprezanja na savijanje [6]	46
Tablica 5.3 Slučajevi opterećenja MKE modela	48
Tablica 5.4 Uključenost Palube 4	60
Tablica 5.5 Izvijanje uzdužno ukrepljenih limova	61
Tablica 5.6 Izvijanje poprečno ukrepljenih limova	62
Tablica 5.7 Očitana naprezanja iz MKE modela uzdužno ukrepljenih limova	62
Tablica 5.8 Očitana naprezanja iz MKE modela poprečno ukrepljenih limova	62

POPIS OZNAKA

- A_u - površina poprečnog presjeka upore, cm^2
 a_v - koeficijent ubrzanja,
 B – širina broda, m
 C_B - koeficijent istisnine
 C_w - koeficijent ovisan o duljini broda
 D – visina broda, m
 e_D - udaljenost neutralne linije do osnovice broda, m
 e_P - udaljenost neutralne linije do linije glavne palube, m
 f - koeficijent za zakrivljena rebra
 $F_{s_negative}$ - negativna smična sila na mirnoj vodi, kN
 $F_{s_positive}$ - pozitivna smična sila na mirnoj vodi, kN
 $F_{w_negative}$ - negativna smična sila na valovitoj vodi, kN
 $F_{w_positive}$ - pozitivna smična sila na valovitoj vodi, kN
 h_a - stvarna (ugrađena) visina hrptenice, mm
 h_{db} - visina hrptenice, mm
 I_y - moment inercije površine glavnog rebra oko osi y, m^4
 k - koeficijent materijala,
 l - nepoduprti raspon, m
 L - duljina broda u metrima, na ljetnoj teretnoj liniji
 l_{k1}, l_{k2} - duljina spoja donjeg/gornjeg koljena, m
 M_{BH_SW} - pregibni moment savijanja na mirnoj vodi, kNm
 M_{BS_SW} - progibni moment savijanja na mirnoj vodi, kNm
 M_{WH} - pregibni moment savijanja na valovitoj vodi, kNm
 M_{WS} - progibni moment savijanja na valovitoj vodi, kNm
 p - opterećenja paluba nastambi, kN/m^2
 P - opterećenje, u kN, od točka ili skupine kotača u polju lima,
 p_1, p_2 - opterećenja punih tankova, kN/m^2
 p_B - opterećenje broskog dna, kN/m^2
 p_D - opterećenje izloženih paluba, kN/m^2
 p_{DA} - opterećenja paluba nadgrađa, kN/m^2
 p_{DB} - opterećenje pokrova dvodna, kN/m^2
 p_{Dmin} - minimalno opterećenje palube čvrstoće, kN/m^2
 p_{dx} - opterećenje djelomično napunjenih tankova, kN/m^2

p_L - opterećenja paluba tereta, kN/m^2
 p_s - opterećenja bokova broda, kN/m^2
 S - razmak između okvirnih rebara, m
 s - razmak rebara, m
 t - debljina lima/opločenja, mm
 t_1 - debljina opločenja dna, mm
 $t_{1\text{min}}$ - najmanja dopuštena debljina opločenja dna, mm
 t_K - dodatak za koroziju
 t_{KB} - debljina plosne kobilice, mm
 t_p - debljina punih rebrenica, mm
 t_s – debljina opločenja boka, mm
 t_u - debljina stijenki cijevnih upora, mm
 W_D - moment otpora za dno, m^3
 W_P - moment otpora za palubu, m^3

SAŽETAK

U ovom radu napravljen je projekt strukture trupa dvostranog trajekta duljine 80 m namijenjen plovidbi po Jadranu. Pomoću Mathcad programskog paketa dimenzionirani su strukturni elementi prema pravilima Hrvatskog registra brodova te je napravljen pripadni nacrt glavnog rebra u softveru AutoCAD. Potom slijedi proračun i provjera strukturnih elemenata primjenom DNV 3D-Beam programskog alata. Dobiveni rezultati modela rešetkaste primarne strukture glavne palube te modela okvira boka garažnog prostora i nadgrađa zadovoljavaju kriterije čvrstoće. Provjereno je i naprezanje strukture dna uslijed dokovanja, koje također zadovoljava. Nadalje, primjenom metode konačnih elemenata pomoću DNV GeniE programskog paketa provjerena je raspodjela globalnih uzdužnih naprezanja u paralelnom srednjaku.

Ključne riječi: *putnički trajekt, čvrstoća broda*

SUMMARY

The main topic of this paper is a hull structure design of an 80 m double-ended ferry, intended for navigation in the Adriatic Sea. The structural ship elements were dimensioned according to the rules of the Croatian Ship Register using the Mathcad software. The drawing of the main midship frame was made in AutoCAD. Then follows the verification of previously calculated structural elements using DNV 3D-Beam software. The obtained results of main deck model and the racking model meet the strength criteria. Docking stress of the bottom structure was also checked and meets the strength criteria. Furthermore, the distribution of global longitudinal stresses in midship section is verified using the finite element method in DNV GeniE software.

Key words: passenger ferry, ship strength

DODATCI

DODATAK A – Proračun u Mathcad programskom paketu

DODATAK B – Nacrt glavnog rebra

DODATAK C – Rešetkasta primarna struktura glavne palube (DNV 3D-Beam)

DODATAK D – Okvir boka garažnog prostora i nadgrađe (DNV 3D-Beam)

DODATAK E – Naprezanje strukture dna uslijed dokovanja (DNV 3D-Beam)

3 DESIGN LOADS

3.1 General

3.1.2 Definitions

3.1.2.1 Load centre:

a) For plates:

– vertical stiffening system:

0,5 x stiffener spacing above the lower support of plate field, or lower edge of plate when the thickness changes within the plate field;

– horizontal stiffening system:

midpoint of plate field.

b) For stiffeners and girders:

- centre of span l .

3.1.2.2 Definition of symbols

v = ship's speed according to Section 1.2.6

ρ_c = density of cargo as stowed, [t/m³]

ρ = density of liquids, [t/m³]

$\rho = 1.025$ t/m³ for fresh and sea water

z = vertical distance of the structure's load centre above base line, [m]

x = distance from aft end of length L , in [m]

C_b = block coefficient according to 1.2.6 (not to be taken less then 0.6)

$p_0 = 2.1 (C_b + 0.7) \times C_w \times C_L \times f$, [kN/m²]

$C_w = L/25 + 4.1$

$C_L = (L/90)^{1/2}$

$f = 1$ for shell plating and weather decks

$f = 0.75$ for frames and deck beams

$f = 0.60$ for web frames, stringers and grillage systems

NOTE: for restricted service areas these values p_0 may be decrease, as follows

- 10 % for service range 2 ($C_{s_r} = 0.9$)
- 25 % for service range 3 ($C_{s_r} = 0.75$)
- 30 % for service range 4, 5 ($C_{s_r} = 0.70$)
- 40 % for service range 6,7,8 ($C_{s_r} = 0.6$)

$$C_{s_r} := 0.7$$

$$v := 12 \quad \text{kn}$$

$$\rho := 1.025 \quad \text{t/m}^3$$

$$L := 76 \quad \text{m}$$

$$d := 2.7 \quad \text{m}$$

$$C_b := 0.68$$

$$D := 4.9 \quad \text{m}$$

$$B := 18 \quad \text{m}$$

$$C_w := \frac{L}{25} + 4.1 = 7.14$$

$$C_L := \left(\frac{L}{90} \right)^{\frac{1}{2}} = 0.919$$

DODATAK A - Proračun u Mathcad programskom paketu

basic external load Shell:

$$f_s := 1$$

$$p_{0s} := 2.1 \cdot (C_b + 0.7) \cdot C_W \cdot C_L \cdot f_s \cdot C_{s_r} = 13.31 \quad \text{kN/m}^2$$

basic external load Fames and deck beams:

$$f_f := 0.75$$

$$p_{0f} := 2.1 \cdot (C_b + 0.7) \cdot C_W \cdot C_L \cdot f_f \cdot C_{s_r} = 9.983 \quad \text{kN/m}^2$$

basic external load Web frames strigers and grillage systems:

$$f_g := 0.6$$

$$p_{0g} := 2.1 \cdot (C_b + 0.7) \cdot C_W \cdot C_L \cdot f_g \cdot C_{s_r} = 7.986 \quad \text{kN/m}^2$$

3.2 External sea loads

3.2.1 Load on weather decks

3.2.1.1 Load on weather deck is determinated as follows:

C_a = factor depending of the longitudinal position

$$C_w := 0.15 \cdot \max(100, L) - 10 = 5$$

$$C_a(x) := \begin{cases} \left(1.2 - \frac{x}{L}\right) & \text{if } \frac{x}{L} < 0.2 \\ 1 & \text{if } 0.2 \leq \frac{x}{L} \leq 0.7 \\ \left[1 + C \cdot \left(\frac{x}{L} - 0.7\right)\right] & \text{if } 0.7 \leq \frac{x}{L} \leq 1.0 \end{cases}$$

$$x := 0 \cdot L .. 1 \cdot L$$

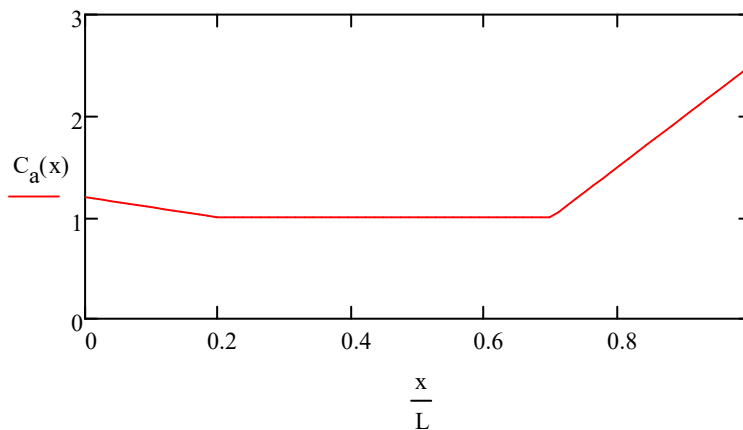

DODATAK A - Proračun u Mathcad programskom paketu

Shell (plating of deck)

DECK 4 - 10900 ABL

$$x := 40 \text{ m}$$

$$z := 10.5 \text{ m}$$

$$P_{Ds}(x, z, C_a) := p_{0s} \cdot \frac{20 \cdot d}{(10 + z - d) \cdot D} \cdot C_a(x)$$

$$P_{Ds}(x, z, C_a) = 8.059 \text{ kN/m}^2$$

DECK 5 - 13700 ABL

$$x := 40 \text{ m}$$

$$z := 13.7 \text{ m}$$

$$P_{Ds}(x, z, C_a) = 6.985 \text{ kN/m}^2$$

Frames (deck beams)

DECK 4 - 10900 ABL

$$x := 40 \text{ m}$$

$$z := 10.5 \text{ m}$$

$$P_{Df}(x, z, C_a) := p_{0f} \cdot \frac{20 \cdot d}{(10 + z - d) \cdot D} \cdot C_a(x)$$

$$P_{Df}(x, z, C_a) = 6.045 \text{ kN/m}^2$$

DECK 5 - 13700 ABL

$$x := 40 \text{ m}$$

$$z := 13.7 \text{ m}$$

$$P_{Df}(x, z, C_a) = 5.239 \text{ kN/m}^2$$

Girders

DECK 4 - 10900 ABL

$$x := 40 \text{ m}$$

$$z := 10.5 \text{ m}$$

$$P_{Dg}(x, z, C_a) := p_{0g} \cdot \frac{20 \cdot d}{(10 + z - d) \cdot D} \cdot C_a(x)$$

$$P_{Dg}(x, z, C_a) = 4.836 \text{ kN/m}^2$$

DECK 5 - 13700 ABL

$$x := 40 \text{ m}$$

$$z := 13.7 \text{ m}$$

$$P_{Dg}(x, z, C_a) = 4.191 \text{ kN/m}^2$$

DODATAK A - Proračun u Mathcad programskom paketu

3.2.1.2 Streight deck which are also weather decks and forcastle decks

Shell (deck plating)

$$p_{Dmin_s} := \max(16 \cdot f_s, 0.7 \cdot p_{0s})$$

$$p_{Dmin_s} = 16 \quad \text{kN/m}^2$$

Frames (deck beams)

$$p_{Dmin_f} := \max(16 \cdot f_f, 0.7 \cdot p_{0f})$$

$$p_{Dmin_f} = 12 \quad \text{kN/m}^2$$

Girders

$$p_{Dmin_g} := \max(16 \cdot f_g, 0.7 \cdot p_{0g})$$

$$p_{Dmin_g} = 9.6 \quad \text{kN/m}^2$$

3.2.2 Load on ship's side

3.2.2.1 Load on ship's sides

$$C_F(x) := \begin{cases} \left[1 + \frac{5}{C_b} \cdot \left(0.2 - \max\left(\frac{x}{L}, 0.1\right) \right) \right] & \text{if } 0 \leq \frac{x}{L} \leq 0.2 \\ 1 & \text{if } 0.2 \leq \frac{x}{L} \leq 0.7 \\ 1 + \frac{20}{C_b} \cdot \left(\min\left(\frac{x}{L}, 0.93\right) - 0.7 \right)^2 & \text{if } 0.7 \leq \frac{x}{L} \leq 1 \end{cases}$$

$$\frac{x}{L} := 0..1$$

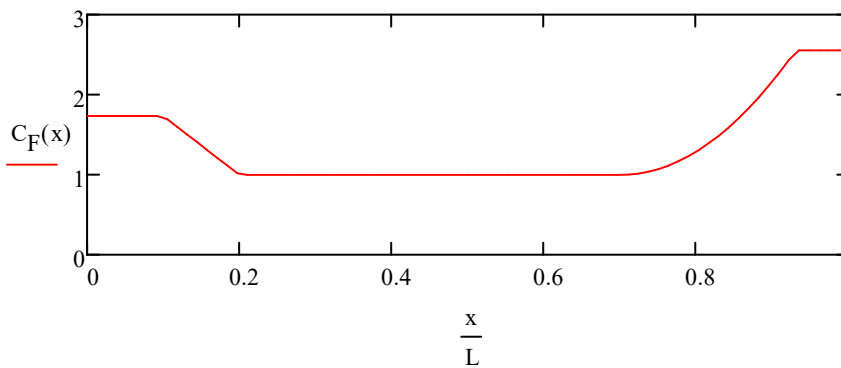

DODATAK A - Proračun u Mathcad programskom paketu

Shell

Elements below load waterline:

$$x := 40 \quad \text{m}$$

$$z := 1 \quad \text{m}$$

$$p_{S_S}(x, z) := \begin{cases} \left[10 \cdot (d - z) + p_{0s} \cdot C_F(x) \cdot \left(1 + \frac{z}{d} \right) \right] & \text{if } z \leq d \\ \left[p_{0s} \cdot C_F(x) \cdot \frac{20}{(10 + z - d)} \right] & \text{if } z > d \end{cases}$$

$$p_{S_S}(x, z) = 35.24 \quad \text{kN/m}^2$$

Opločenje boka (Paluba 1 - Paluba 2)

$$x := 40 \quad \text{m}$$

$$z := 2.5 \quad \text{m}$$

$$p_{S_S}(x, z) = 27.634 \quad \text{kN/m}^2$$

Ukrepe boka (Paluba 1 - Paluba 2)

$$x := 40 \quad \text{m}$$

$$z := 3.55 \quad \text{m}$$

$$p_{S_S}(x, z) = 24.535 \quad \text{kN/m}^2$$

Opločenje boka (Paluba 2 - Paluba 3)

$$x := 40 \quad \text{m}$$

$$z := 5.2 \quad \text{m}$$

$$p_{S_S}(x, z) = 21.296 \quad \text{kN/m}^2$$

Ukrepe boka (Paluba 2 - Paluba 3)

$$x := 40 \quad \text{m}$$

$$z := 6.5 \quad \text{m}$$

$$p_{S_S}(x, z) = 19.29 \quad \text{kN/m}^2$$

Opločenje boka (Paluba 3 - Paluba 4)

$$x := 40 \quad \text{m}$$

$$z := 8.4 \quad \text{m}$$

$$p_{S_S}(x, z) = 16.955 \quad \text{kN/m}^2$$

DODATAK A - Proračun u Mathcad programskom paketu

Ukrepe boka (Paluba 3 - Paluba 4)

$$\underline{x} := 40 \quad \text{m}$$

$$\underline{z} := 9.5 \quad \text{m}$$

$$P_{S_s}(x, z) = 15.845 \quad \text{kN/m}^2$$

BOTTOM LONGITUDINALS

$$\underline{x} := 40 \quad \text{m}$$

$$\underline{z} := 0 \quad \text{m}$$

$$P_{S_f}(x, z) := \begin{cases} \left[10 \cdot (d - z) + p_{0f} \cdot C_F(x) \cdot \left(1 + \frac{z}{d} \right) \right] & \text{if } z \leq d \\ \left[p_{0f} \cdot C_F(x) \cdot \frac{20}{(10 + z - d)} \right] & \text{if } z > d \end{cases}$$

$$P_{S_f}(x, z) = 36.983 \quad \text{kN/m}^2$$

$$\underline{x} := 40 \quad \text{m}$$

$$\underline{z} := 2.5 \quad \text{m}$$

$$P_{S_f}(x, z) = 21.226 \quad \text{kN/m}^2$$

Elements above load waterline:

$$\underline{x} := 40 \quad \text{m}$$

$$\underline{z} := 5.2 \quad \text{m}$$

$$P_{S_f}(x, z) = 15.972 \quad \text{kN/m}^2$$

$$\underline{x} := 40 \quad \text{m}$$

$$\underline{z} := 8.4 \quad \text{m}$$

$$P_{S_f}(x, z) = 12.717 \quad \text{kN/m}^2$$

$$\underline{x} := 40 \quad \text{m}$$

$$\underline{z} := 11 \quad \text{m}$$

$$P_{S_f}(x, z) = 10.91 \quad \text{kN/m}^2$$

DODATAK A - Proračun u Mathcad programskom paketu

3.2.3 Load on ship's bottom

$$x := 40 \text{ m}$$

$$p_B(x) := 10 \cdot d + p_{0s} \cdot C_F(x)$$

$$p_B(x) = 40.31 \quad \text{kN/m}^2$$

3.2.5 Load on decks of superstructures and deckhouses

3.2.5.1 Load on exposed decks and parts of superstructure and deckhouse decks which are not treated as strength deck

1.If deckhouse deck is calculated then -> deck_house=1, forecastle_deck=0, exposed_wheel_house_top=0, other_decks=0

2.If forecastle deck is calculated then -> deck_house=0, forecastle_deck=1, exposed_wheel_house_top=0, other_decks=0

3.If exposed wheel house top is calculated then -> deck_house=0, forecastle_deck=0, exposed_wheel_house_top=1, other_decks=0

4.If other decks are calculated then ->deck_house=0, forecastle_deck=0, exposed_wheel_house_top=0, other_decks=1

$$\text{deck_house} := 0$$

$$\text{forecastle_deck} := 0$$

$$\text{exposed_wheel_house_top} := 0$$

$$\text{other_decks} := 1$$

For deck house deck calculation:

b' = breadth of deckhouse;

B' = largest breadth of ship at the position considered.

$$b'' := 15 \text{ m}$$

$$B'' := 15 \text{ m}$$

Plating

$$x := 40 \text{ m}$$

$$z := 14.9 \text{ m}$$



$$PDA_{\text{plating}}(x, z, \text{deck_house}, \text{forecastle_deck}, \text{exposed_wheel_house_top}, \text{other_decks}, C_a, p_{Ds})$$

$$:= \begin{cases} \max \left[p_{Ds}(x, z, C_a) \cdot \max \left[1 - \left(\frac{z-D}{10} \right), 0.5 \right], 4 \right] & \text{if other_decks} = 1 \wedge \text{deck_house} = 0 \wedge \text{forecastle_deck} = 0 \wedge \text{exposed_wheel_house_top} = 0 \\ \max \left[p_{Ds}(x, z, C_a) \cdot \max \left[1 - \left(\frac{z-D}{10} \right), 0.5 \right], 2.5 \right] & \text{if exposed_wheel_house_top} = 1 \wedge \text{other_decks} = 0 \wedge \text{deck_house} = 0 \wedge \text{forecastle_deck} = 0 \\ \max(p_{Ds}(x, z, C_a) \cdot 1, p_{Dmin_s}) & \text{if forecastle_deck} = 1 \wedge \text{other_decks} = 0 \wedge \text{exposed_wheel_house_top} = 0 \wedge \text{deck_house} = 0 \\ \max \left[p_{Ds}(x, z, C_a) \cdot \max \left[1 - \left(\frac{z-D}{10} \right), 0.5 \right], \left(0.7 \cdot \frac{b''}{B''} + 0.3 \right), 4 \right] & \text{if deck_house} = 1 \wedge \text{other_decks} = 0 \wedge \text{exposed_wheel_house_top} = 0 \wedge \text{forecastle_deck} = 0 \end{cases}$$

$$PDA_{\text{plating}}(x, z, \text{deck_house}, \text{forecastle_deck}, \text{exposed_wheel_house_top}, \text{other_decks}, C_a, p_{Ds}) = 4 \quad \text{kN/m}^2$$

DODATAK A - Proračun u Mathcad programskom paketu

Stiffeners

$$\underline{x} := 40 \text{ m}$$

$$\underline{z} := 10 \text{ m}$$



$$PDA_stiffeners(x, z, deck_house, forecastle_deck, exposed_wheel_house_top, other_decks, C_a, p_{Ds})$$

$$:= \begin{cases} \max \left[p_{Df}(x, z, C_a) \cdot \max \left[1 - \left(\frac{z-D}{10} \right), 0.5 \right], 4 \right] & \text{if } other_decks = 1 \wedge deck_house = 0 \wedge forecastle_deck = 0 \wedge exposed_wheel_house_top = 0 \\ \max \left[p_{Df}(x, z, C_a) \cdot \max \left[1 - \left(\frac{z-D}{10} \right), 0.5 \right], 2.5 \right] & \text{if } exposed_wheel_house_top = 1 \wedge other_decks = 0 \wedge deck_house = 0 \wedge forecastle_deck = 0 \\ \max(p_{Df}(x, z, C_a) \cdot 1, p_{Dmin_f}) & \text{if } forecastle_deck = 1 \wedge other_decks = 0 \wedge exposed_wheel_house_top = 0 \wedge deck_house = 0 \\ \max \left[p_{Df}(x, z, C_a) \cdot \max \left[1 - \left(\frac{z-D}{10} \right), 0.5 \right] \cdot \left(0.7 \cdot \frac{b^*}{B^*} + 0.3 \right), 4 \right] & \text{if } deck_house = 1 \wedge other_decks = 0 \wedge exposed_wheel_house_top = 0 \wedge forecastle_deck = 0 \end{cases}$$

$$PDA_stiffeners(x, z, deck_house, forecastle_deck, exposed_wheel_house_top, other_decks, C_a, p_{Ds}) = 4 \quad \text{kN/m}^2$$

Girders

$$\underline{x} := 40 \text{ m}$$

$$\underline{z} := 10 \text{ m}$$



$$PDA_girders(x, z, deck_house, forecastle_deck, exposed_wheel_house_top, other_decks, C_a, p_{Ds})$$

$$:= \begin{cases} \max \left[p_{Dg}(x, z, C_a) \cdot \max \left[1 - \left(\frac{z-D}{10} \right), 0.5 \right], 4 \right] & \text{if } other_decks = 1 \wedge deck_house = 0 \wedge forecastle_deck = 0 \wedge exposed_wheel_house_top = 0 \\ \max \left[p_{Dg}(x, z, C_a) \cdot \max \left[1 - \left(\frac{z-D}{10} \right), 0.5 \right], 2.5 \right] & \text{if } exposed_wheel_house_top = 1 \wedge other_decks = 0 \wedge deck_house = 0 \wedge forecastle_deck = 0 \\ \max(p_{Dg}(x, z, C_a) \cdot 1, p_{Dmin_g}) & \text{if } forecastle_deck = 1 \wedge other_decks = 0 \wedge exposed_wheel_house_top = 0 \wedge deck_house = 0 \\ \max \left[p_{Dg}(x, z, C_a) \cdot \max \left[1 - \left(\frac{z-D}{10} \right), 0.5 \right] \cdot \left(0.7 \cdot \frac{b^*}{B^*} + 0.3 \right), 4 \right] & \text{if } deck_house = 1 \wedge other_decks = 0 \wedge exposed_wheel_house_top = 0 \wedge forecastle_deck = 0 \end{cases}$$

$$PDA_girders(x, z, deck_house, forecastle_deck, exposed_wheel_house_top, other_decks, C_a, p_{Ds}) = 4 \quad \text{kN/m}^2$$

3.3 Cargo loads, load on accomodation decks

3.3.1 Load on cargo decks

3.3.1.1 Load on cargo deck is determinated as follows

p_c = static cargo load, in [kN/m²] (if cargo load is unknown the left 0 as value)

$$p_c := 0 \text{ kN/m}^2$$

h = mean 'tween deck height, in [m]

$$h := 2.12 \text{ m}$$

$$p_{c1}(p_c, h) := \begin{cases} p_c & \text{if } p_c \neq 0 \\ (7 \cdot h) & \text{if } p_c = 0 \end{cases}$$

DODATAK A - Proračun u Mathcad programskom paketu

$$p_{c1}(p_c, h) = 14.84 \quad \text{kN/m}^2$$

a_v = acceleration factor as follows:

$$F := 0.11 \cdot \frac{\max(v, \sqrt{L})}{\sqrt{L}}$$

$$m_0 := 1.5 + F$$

$$x := 0..L$$

$$m(x) := \begin{cases} \left[m_0 - 5 \cdot (m_0 - 1) \cdot \frac{x}{L} \right] & \text{if } 0 < \frac{x}{L} \leq 0.2 \\ 1 & \text{if } 0.2 < \frac{x}{L} \leq 0.7 \\ \left[1 + \frac{(m_0 + 1)}{0.3} \cdot \left(\frac{x}{L} - 0.7 \right) \right] & \text{if } 0.7 < \frac{x}{L} \leq 1 \end{cases}$$

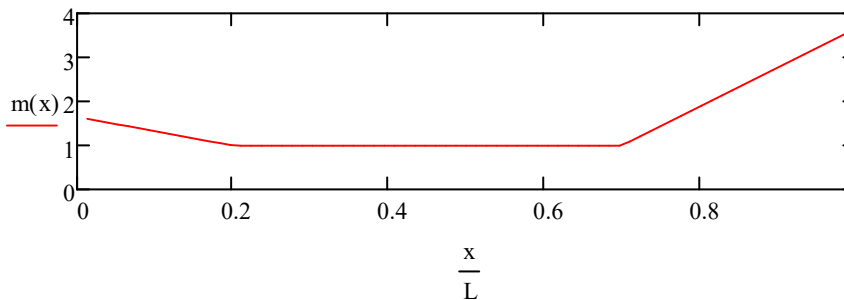

$$a_v(x) := F \cdot m(x)$$

$$x := 40 \quad \text{m}$$

p_L = cargo load [kN/m²]

$$p_L(p_{c1}, a_v, x) := p_{c1}(p_c, h) \cdot (1 + a_v(x))$$

$$p_L(p_{c1}, a_v, x) = 17.087 \quad \text{kN/m}^2$$

3.3.2 Load on inner bottom

3.3.2.1 Inner bottom cargo loads

G = mass of cargo in the hold, [t]

$$G := 82 \quad \text{t}$$

V = volume of the hold, in [m³], (hatchways excluded)

$$V := 970 \quad \text{m}^3$$

h = height of the highest point of the cargo above the inner bottom, in [m], assuming hold to be completely filled

DODATAK A - Proračun u Mathcad programskom paketu

$$h := 2.12 \text{ m}$$

$x := 40$ m For calculating a_v , the distance between the centre of gravity of the hold and the aft end of the length L is to be taken.

$$P_{DB}(x, G, V, h, a_v) := 9.81 \cdot \frac{G}{V} \cdot h \cdot (1 + a_v(x))$$

$$P_{DB}(x, G, V, h, a_v) = 2.024 \text{ kN/m}^2$$

3.3.3 Loads on accommodation and machinery decks

3.3.3.1 Deck load in accommodation and service spaces

$$x := 40 \text{ m}$$

$$p(x) := 3.5 \cdot (1 + a_v(x))$$

$$p(x) = 4.03 \text{ kN/m}^2$$

3.3.3.2 Deck load on machinery decks

$$x := 40$$

$$p(x) := 8 \cdot (1 + a_v(x))$$

$$p(x) = 9.211$$

3.4 Load on tank structures

3.4.1 Design pressure for filed tanks

3.4.1.1 Design pressure for service condition is the greater value obtained by next procedure

h_1 = distance of load centre from tank top, in [m];

a_v = acceleration factor, see 3.3.1.1;

ϕ = design heeling angle, [°], for tanks;

= $\arctan(f_{bk} \times D/B)$, in general;

$f_{bk} = 0,5$ for ships with bilge keel

= $0,6$ for ships without bilge keel

$\phi \geq 20^\circ$ for hatch covers of holds carrying liquids

b = upper breadth of tank, [m];

y = distance of load centre from the vertical longitudinal central plane of tank, [m];

p_v = set pressure of pressure relief valve, [bar], (if a pressure relief valve is fitted);

$p_{vmin} = 0,1$ bar (1,0 mSV), during ballast water exchange for both, the sequential method as well as the flow-through method;

$p_{vmin} = 0,2$ [bar] (2,0 mSV) for cargo tanks of tankers;

mSV = metre of head water.

$$h_1 := 2.2 \text{ m}$$

If ship have bilge keel then -> bilge_keel=1

If ship doesn't have bilge keel -> bilge_keel=0

$$\text{bilge_keel} := 0$$

$$f_{bk} := \begin{cases} 0.5 & \text{if bilge_keel} = 1 \\ 0.6 & \text{if bilge_keel} = 0 \end{cases}$$

If calculating hatch covers of holds carrying liquids-> hatch_liquid=1

if not-> hatch_liquid=0

DODATAK A - Proračun u Mathcad programskom paketu

hatch_liquid := 1

$$\phi(\text{bilge_keel}, \text{hatch_liquid}) := \begin{cases} \text{atan}\left(f_{bk} \cdot \frac{D}{B}\right) & \text{if hatch_liquid} = 0 \\ \left(20 \cdot \frac{\pi}{180}\right) & \text{if hatch_liquid} = 1 \end{cases}$$

b := 8.4 m

y := 0 m $\phi(\text{bilge_keel}, \text{hatch_liquid}) = 0.349$

If pressure relief valve is fitted then -> prs_relief=1
 If pressure relief valve is not fitted then -> prs_relief=0
 If pressure relief valve is fitted then fill the value p_{prv}

prs_relief := 1

p_{prv} := 0 bar

$$p_v(\text{prs_relief}, p_{prv}) := \begin{cases} p_{prv} & \text{if prs_relief} = 1 \\ 0.1 & \text{if prs_relief} = 0 \end{cases}$$

$p_v(\text{prs_relief}, p_{prv}) = 0$ bar

x := 40 m



$$p_1(x, h_1, a_v, p_v, \rho, \phi, y, b) := \max\left[9.81 \cdot h_1 \cdot \rho \cdot (1 + a_v(x)) + 100 \cdot p_v(\text{prs_relief}, p_{prv}),\right. \\ \left.9.81 \cdot \rho \cdot [h_1 \cdot \cos(\phi(\text{bilge_keel}, \text{hatch_liquid})) + (0.3 \cdot b + y) \cdot \sin(\phi(\text{bilge_keel}, \text{hatch_liquid}))] + 100 \cdot p_v(\text{prs_relief}, p_{prv})\right]$$

WATER TANK IN DOUBLE BOTTOM

$h_1 := 2.2$ m

$$p_1(x, h_1, a_v, p_v, \rho, \phi, y, b) = 29.454 \quad \text{kN/m}^2$$

ROLL REDUCTION TANK AT DECK 5

$h_1 := 1.2$ m

$$p_1(x, h_1, a_v, p_v, \rho, \phi, y, b) = 20.005 \quad \text{kN/m}^2$$

3.4.1.2 Maximum static design pressure

h_2 = distance of load centre from top of overflow or from a point 2,5 m above tank top, whichever is the greater. Tank venting pipes of cargo tanks of tankers are not to be regarded as overflow pipes

$h_2 := 2.2$ m

For tanks equipped with pressure relief valves and/or for tanks intended to carry liquids of a density greater than 1 t/m³, the head h_2 is at least to be measured to a level at the following distance hp above tank top

DODATAK A - Proračun u Mathcad programskom paketu

p_{v1} = pressure of pressure relief valve

$$p_{v1} := 0 \text{ bar}$$

$$p_{v12}(p_{v1}, \rho) := \max(p_{v1}, 0.25 \cdot \rho)$$

$$h_p(p_{v12}, p_{v1}, \rho) := 9.81 \cdot p_{v12}(p_{v1}, \rho)$$

$$h_p(p_{v12}, p_{v1}, \rho) = 2.514 \text{ m}$$

h_{of} = height of top of the overflow above tanktop [m]



$$p_2(h_2, h_p, h_{of}, p_{v1}, p_{v12}, \rho) := \begin{cases} (9.81 \cdot h_2) & \text{if } h_2 > h_2 - \max(2.5, h_{of}) + h_p(p_{v12}, p_{v1}, \rho) \\ \left[\left[9.81 \cdot (h_2 - \max(2.5, h_{of}) + h_p(p_{v12}, p_{v1}, \rho)) \right] \right] & \text{if } h_2 \leq h_2 - \max(2.5, h_{of}) + h_p(p_{v12}, p_{v1}, \rho) \end{cases}$$

WATER TANK IN DOUBLE BOTTOM

$$h_2 := 2.2 \text{ m}$$

$$h_{of} := 2.2 \text{ m}$$

$$p_2(h_2, h_p, h_{of}, p_{v1}, p_{v12}, \rho) = 21.718 \text{ kN/m}^2$$

ROLL REDUCTION TANK AT DECK 5

$$h_2 := 1.2 \text{ m}$$

$$h_{of} := 1.2 \text{ m}$$

$$p_2(h_2, h_p, h_{of}, p_{v1}, p_{v12}, \rho) = 11.908 \text{ kN/m}^2$$

3.4.2 Design pressure for partially filled tanks

3.4.2.1 For tanks which are partially filled between 20% and 90% of their volume design loads are obtained with next sequence.

a) For structures within $l_t/4$ from the bulkheads limiting the free surface in longitudinal ship direction

p_v = set pressure of pressure relief valve, [bar], (if a pressure relief valve is fitted)

$$p_{v2} := 0.1 \text{ bar}$$

l_t = distance, in [m], between transverse bulkheads or effective transverse wash bulkheads at the height where the structure is located;

$$l_t := 5$$

x_1 = distance of structural element from the tank's ends in the ship's longitudinal direction, in [m]

$$x_1 := 1$$

$$n_x(x_1) := 1 - \frac{4}{l_t} \cdot x_1$$

$$n_x(x_1) = 0.2$$

DODATAK A - Proračun u Mathcad programskom paketu

$$p_{dx}(l_t, n_x, p_{v2}, \rho, x_1) := \left(4 - \frac{L}{150}\right) \cdot l_t \cdot \rho \cdot n_x(x_1) + 100 \cdot p_{v2}$$

$$p_{dx}(l_t, n_x, p_{v2}, \rho, x_1) = 13.581 \quad \text{kN/m}^2$$

b) For structures within $b_t/4$ from the bulkheads limiting the free surface in transversal ship direction

b_t = distance in, [m], between tank sides or effective longitudinal wash bulkhead at the height where the structure is located;

$$b_t := 3 \quad \text{m}$$

y_1 = distance of structural element from the tank's ends in the ship's transverse direction, in [m]

$$y_1 := 0.5 \quad \text{m}$$

$$n_y(y_1) := 1 - \frac{4}{b_t} \cdot y_1$$

$$n_y(y_1) = 0.333$$

$$p_{dy}(b_t, \rho, n_y, p_{v2}, y_1) := \left(4 - \frac{B}{20}\right) \cdot b_t \cdot \rho \cdot n_y(y_1) + 100 \cdot p_{v2}$$

$$p_{dy}(b_t, \rho, n_y, p_{v2}, y_1) = 13.178 \quad \text{kN/m}^2$$

3.5 Design values of acceleration components

3.5.1 Acceleration components

$$A_{\omega}(z) := \left[0.7 - \left(\frac{\max(L, 100)}{1200}\right) + 5 \cdot \left[\frac{(z - d)}{\max(L, 100)}\right]\right] \cdot \frac{0.6}{C_b}$$

f = factor depending on probability level Q as outlined in Table

$f :=$

	0	1
0	"Q"	"f"
1	"10 ⁻⁸ "	1
2	"10 ⁻⁷ "	0.875
3	"10 ⁻⁶ "	0.75
4	"10 ⁻⁵ "	0.625
5	"10 ⁻⁴ "	0.5

$$f_{\omega} := 1$$

$$a_{0\omega} := \left[0.2 \cdot \left(\frac{v}{\sqrt{\max(L, 100)}}\right) + \frac{(3 \cdot C_W \cdot C_L)}{\max(L, 100)}\right] \cdot f$$

DODATAK A - Proračun u Mathcad programskom paketu

GM = metacentric height, in [m]

$$GM := 0.5 \text{ m}$$

$$k := \max\left(13 \cdot \frac{GM}{B}, 1\right)$$

a_x, a_y, a_z = maximum dimensionless accelerations (i.e., relative to the acceleration of gravity g) in the related directions x, y and z .

$$a_z(x) := a_0 \cdot \sqrt{1 + \left(5.3 - \frac{45}{L}\right)^2 \cdot \left(\frac{x}{L} - 0.45\right)^2 \left(\frac{0.6}{C_b}\right)^{1.5}}$$

$$\underline{x} := 0..L$$

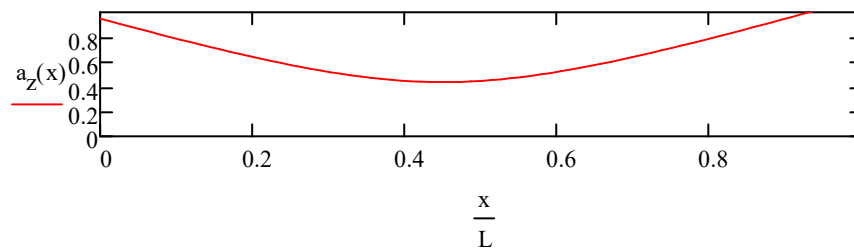

$$x := 40 \text{ m}$$

$$a_z(x) = 0.46$$

$$a_y(x, z) := a_0 \cdot \sqrt{0.6 + 2.5 \cdot \left(\frac{x}{L} - 0.45\right)^2 + k \cdot \left[1 + 0.6 \cdot k \cdot \frac{(z-d)}{B}\right]^2}$$

$$\underline{x} := 0..L \quad \underline{z} := 0..D$$

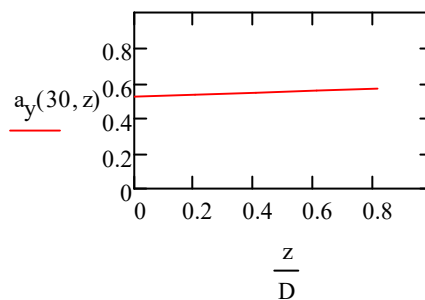
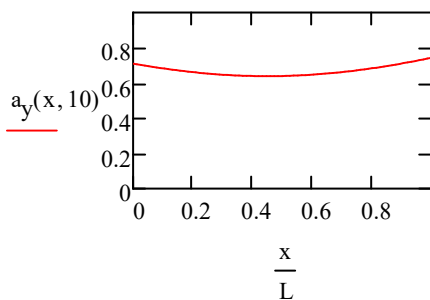

$$x := 40 \text{ m}$$

$$z := 10.2 \text{ m}$$

$$a_y(x, z) = 0.645$$

$$a_x(z) := a_0 \cdot \sqrt{0.06 + A(z)^2 - 0.25 A(z)}$$

$$\underline{z} := 0..D$$

DODATAK A - Proračun u Mathcad programskom paketu

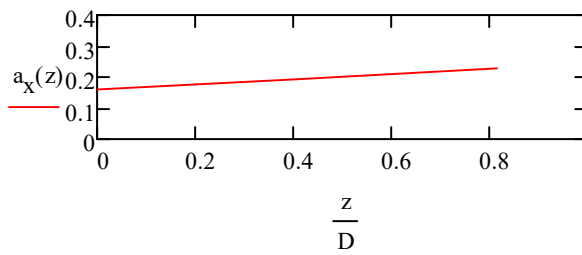

$z := 10 \text{ m}$

$$a_x(z) = 0.337$$

DODATAK A - Proračun u Mathcad programskom paketu

PRINCIPAL DATA :

Length in m,	$L := 76$
Breadth moulded in m,	$B := 18$
Depth moulded in m,	$D := 4.9$
Draught moulded in m,	$d := 2.7$
Block coefficient,	$C_b := 0.68$
Vessel design velocity in kn	$v := 12$
Density of sea water t/m ³	$\rho := 1.025$

4 LONGITUDINAL STRENGTH

4.1 General

4.1.2 Definitons

M_B = still water bending moment, in [kNm];

M_w = vertical wave bending moment, in [kNm];

C_w = wave coefficient depending on length;

F_s = still water shear force, in [kN];

F_w = vertical wave shear force, in [kN];

I_y = moment of inertia of the transversal section, in [cm⁴], around the horizontal axis;

W = section modulus of transversal section around the horizontal axis, in [cm³];

S = first moment of the sectional area of the longitudinal members, in [cm³], related to the neutral axis;

C_b = block coefficient;

v = maximum speed of ship, in [kn], at defined shaft revolution and engine power.

k = material factor according to 1.4.2.2

x = distance, in [m], between aft end of length L and the position considered

H_{sg}, H_{sd} = vertical extent of HS steel used in deck or bottom, [m]

4.1.3 Explanations

- **Longitudinal members** - parts of hull structure which participate in longitudinal strength and which extend continuously over $0,4 \cdot L$ amidship.
- **Strength deck** - is the deck forming the upper flange of the hull girder. That may be deck of a midship superstructure if it is at $0,4 L$ amidship and extend in length greater than: $L = 3 \times (B/2 + h)$, [m] where:
 h = height from uppermost continuous deck to the deck considered, in [m].
- **Longitudinal bulkhead** - longitudinal bulkhead which extend from bottom to deck and which is effectively connected with shell plating by transversal bulkheads at both ends.
- **Effective shear area of shell or inner shell** - area of entire height.
- **Effective shear area of longitudinal bulkhead** - area of entire height of bulkhead. Where bulkhead is corrugated area of cross section is to be deducted for relation between projected and developed length of corrugation

DODATAK A - Proračun u Mathcad programskom paketu

4.2 Vertical longitudinal bending moments and shear forces

4.2.1 Still water bending moment and shear force

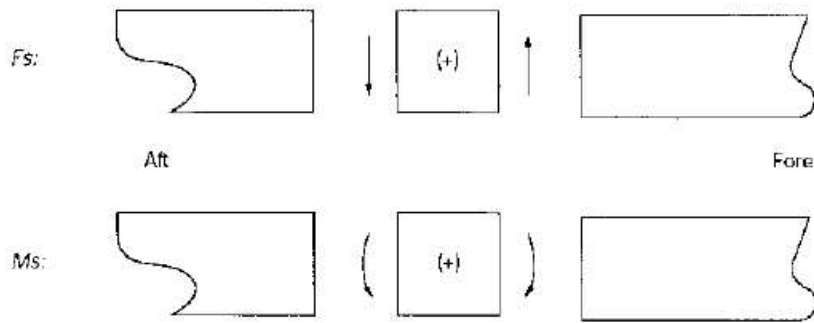

Sign convention of M_B and F_S

Next values of bending moments on still water are defined from weight and buoyancy distribution along the ship

M_{BH_SW} = Bending moment at considered longitudinal section in hogging on still water [kNm]

$$M_{BH_SW} := 29430 \quad \text{kNm} \quad M_{BH_SW} = 3000 \text{ TM}$$

M_{BS_SW} = Bending moment at considered longitudinal section in sagging on still water [kNm]

$$M_{BS_SW} := -29430 \quad \text{kNm} \quad M_{BS_SW} = -3000 \text{ TM}$$

4.2.2 Wave bending moment

$$C_w := \begin{cases} 10.75 - \left(\frac{300 - L}{100}\right)^{1.5} & \text{if } L \leq 300 \\ 10.75 & \text{if } 300 < L \leq 350 \\ 10.75 - \left(\frac{L - 350}{300}\right)^{1.5} & \text{if } 350 < L \leq 500 \end{cases} = 7.397$$

$$M(x) := \begin{cases} \left(2.5 \cdot \frac{x}{L}\right) & \text{if } \frac{x}{L} < 0.4 \\ 1 & \text{if } 0.4 \leq \frac{x}{L} \leq 0.65 \\ \left(\left(\frac{1 - \frac{x}{L}}{0.35}\right)\right) & \text{if } \frac{x}{L} > 0.65 \end{cases}$$

DODATAK A - Proračun u Mathcad programskom paketu

$x := 0..L$

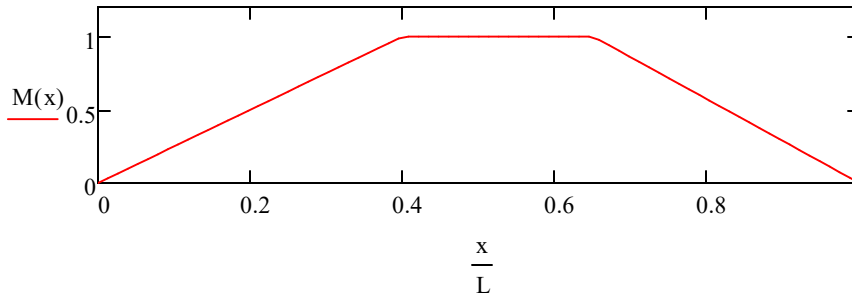

$x := 40$ m

Wave bending moment for ships in limited service conditions may be reduced as follows:

- navigation area 7 and 8 for 40%, $C_{NA}=0.60$
- navigation area 5 and 6 for 30%, $C_{NA}=0.70$
- navigation area 3 and 4 for 25%, $C_{NA}=0.75$
- navigation area 2 for 10%, $C_{NA}=0.90$
- navigation area 1 for 0%. $C_{NA}=1.00$

$C_{NA} := 0.70$

M_{WH} = wave bending moment Hogging

$$M_{WH}(x) := 190 \cdot M(x) \cdot C_W \cdot L^2 \cdot B \cdot \max(C_b, 0.6) \cdot 10^{-3} \cdot C_{NA}$$

$$M_{WH}(x) = 6.956 \times 10^4 \text{ kNm}$$

M_{WS} = wave bending moment Sagging

$$M_{WS}(x) := -110 \cdot M(x) \cdot C_W \cdot L^2 \cdot B \cdot (\max(C_b, 0.6) + 0.7) \cdot 10^{-3} \cdot C_{NA}$$

$$M_{WS}(x) = -8.172 \times 10^4 \text{ kNm}$$

4.2.3 Wave shear force

F_1, F_2 = Distribution factors

$$m_{\text{max}} := \left[\frac{0.92 \cdot 190 \cdot \max(C_b, 0.6)}{110 \cdot (\max(C_b, 0.6) + 0.7)} \right]$$

DODATAK A - Proračun u Mathcad programskom paketu

$$F_1(x) := \begin{cases} \left[5 \cdot m \cdot \left(\frac{x}{L} \right) \right] & \text{if } 0 \leq \left(\frac{x}{L} \right) < 0.2 \\ m & \text{if } 0.2 \leq \left(\frac{x}{L} \right) < 0.3 \\ \left[4 \cdot m - 2.1 + (7 - 10 \cdot m) \cdot \left(\frac{x}{L} \right) \right] & \text{if } 0.3 \leq \left(\frac{x}{L} \right) < 0.4 \\ 0.7 & \text{if } 0.4 \leq \left(\frac{x}{L} \right) < 0.6 \\ \left[3 \cdot \left(\frac{x}{L} \right) - 1.1 \right] & \text{if } 0.6 \leq \left(\frac{x}{L} \right) < 0.7 \\ 1 & \text{if } 0.7 \leq \left(\frac{x}{L} \right) < 0.85 \\ \left[\left(\frac{100}{15} \right) \left[1 - \left(\frac{x}{L} \right) \right] \right] & \text{if } 0.85 \leq \left(\frac{x}{L} \right) \leq 1 \end{cases}$$

$$\frac{x}{L} := 0..1$$

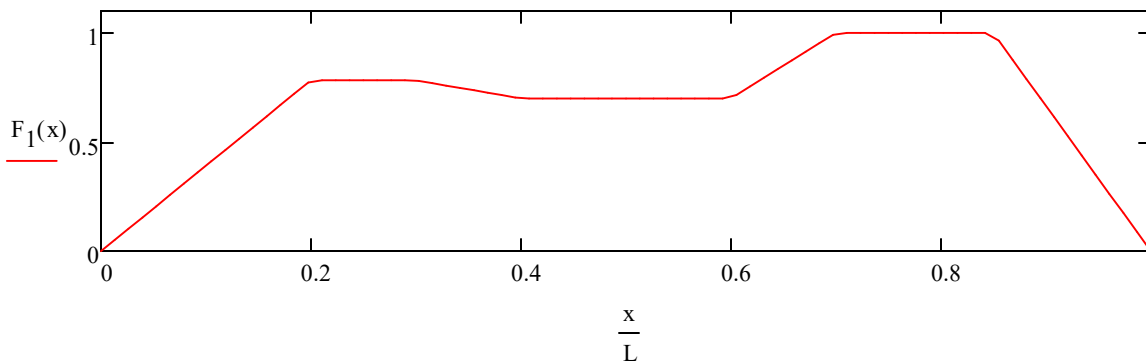

$$m_1 := \left[\frac{190 \cdot C_b}{110 \cdot (\max(C_b, 0.6) + 0.7)} \right]$$

DODATAK A - Proračun u Mathcad programskom paketu

$$F_2(x) := \begin{cases} \left[4.6 \cdot \left(\frac{x}{L} \right) \right] & \text{if } 0 \leq \left(\frac{x}{L} \right) < 0.2 \\ 0.92 & \text{if } 0.2 \leq \left(\frac{x}{L} \right) < 0.3 \\ \left[1.58 - 2.2 \cdot \left(\frac{x}{L} \right) \right] & \text{if } 0.3 \leq \left(\frac{x}{L} \right) < 0.4 \\ 0.7 & \text{if } 0.4 \leq \left(\frac{x}{L} \right) < 0.6 \\ \left[4.9 - 6 \cdot m_1 + (10 \cdot m_1 - 7) \cdot \left(\frac{x}{L} \right) \right] & \text{if } 0.6 \leq \left(\frac{x}{L} \right) < 0.7 \\ m_1 & \text{if } 0.7 \leq \left(\frac{x}{L} \right) < 0.85 \\ \left[m_1 \cdot \left(\frac{100}{15} \right) \left[1 - \left(\frac{x}{L} \right) \right] \right] & \text{if } 0.85 \leq \left(\frac{x}{L} \right) \leq 1 \end{cases}$$

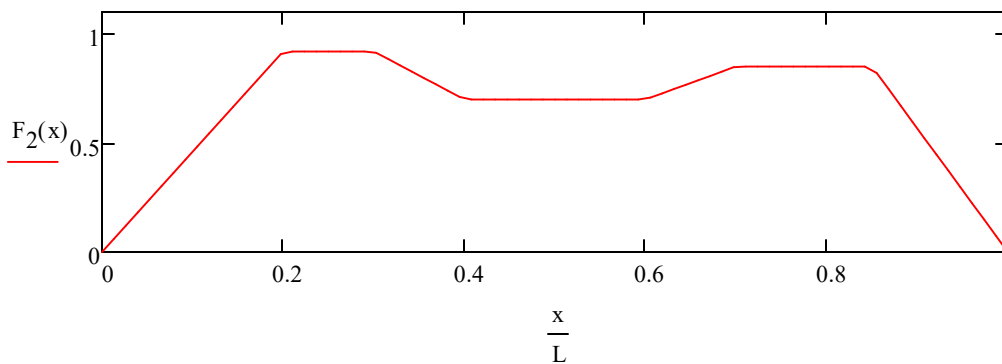

$$F_{w_positive}(x) := 30 \cdot F_1(x) \cdot C_w \cdot L \cdot B \cdot (\max(C_b, 0.6) + 0.7) \cdot 10^{-2}$$

$$F_{w_negative}(x) := -30 \cdot F_2(x) \cdot C_w \cdot L \cdot B \cdot (\max(C_b, 0.6) + 0.7) \cdot 10^{-2}$$

$$x := 40 \text{ m}$$

$$F_{w_positive}(x) = 2.933 \times 10^3 \text{ kN}$$

$$F_{w_negative}(x) = -2.933 \times 10^3 \text{ kN}$$

4.3 Bending strenght

4.3.2 Section modulus strenght criteria

k = material factor

k = 0,78, for steel with $ReH = 315 \text{ N/mm}^2$,

k = 0,72, for steel with $ReH = 355 \text{ N/mm}^2$,

k = 0,66, for steel with $ReH = 390 \text{ N/mm}^2$ provided that a fatigue assessment of the structure is performed to verify compliance with the requirements of the *Register*,

k = 0,68, for steel with $ReH = 390 \text{ N/mm}^2$ in other cases.

k := 1

$\frac{x}{L} := 40$

$$\sigma(x) := \begin{cases} \left[\left[0.5 + \left(\frac{5}{3} \right) \cdot \left(\frac{x}{L} \right) \cdot \left(\frac{18.5 \cdot \sqrt{L}}{k} \right) \right] \right] & \text{if } \left(\frac{x}{L} \right) < 0.3 \\ \left(\frac{18.5 \cdot \sqrt{L}}{k} \right) & \text{if } 0.3 \leq \left(\frac{x}{L} \right) \leq 0.7 \\ \left[\left(\frac{5}{3} \right) \cdot \left[1.3 - \left(\frac{x}{L} \right) \right] \cdot \left(\frac{18.5 \cdot \sqrt{L}}{k} \right) \right] & \text{if } \left(\frac{x}{L} \right) > 0.7 \end{cases}$$

$\sigma(x) = 161.279 \text{ N/mm}^2$

$$W_{H_min}(x) := \left(\frac{|M_{BH_SW} + M_{WH}(x)|}{\sigma(x)} \right) \cdot 10^3$$

$W_{H_min}(x) = 6.138 \times 10^5 \text{ cm}^3$

$$W_{S_min}(x) := \left(\frac{|M_{BS_SW} + M_{WS}(x)|}{\sigma(x)} \right) \cdot 10^3$$

$W_{S_min}(x) = 6.892 \times 10^5 \text{ cm}^3$

4.3.4 Minimum midship section modulus

Minimum midship section modulus for ships in limited service conditions may be reduced as follows:

- 0% for navigation area 1 $C_{NAW}=1.00$
- 5% for navigation area 2 $C_{NAW}=0.95$
- 15% for navigation area 3 $C_{NAW}=0.85$
- 20% for navigation area 4,5 $C_{NAW}=0.80$
- 25% for navigation area 6,7,8 $C_{NAW}=0.75$

$C_{NAW} := 0.8$

DODATAK A - Proračun u Mathcad programskom paketu

$$W_{\min} := C_w \cdot L^2 \cdot B \cdot (\max(C_b, 0.6) + 0.7) \cdot k \cdot C_{NAW}$$

$$W_{\min} = 8.491 \times 10^5 \text{ cm}^3$$

$$W_{\min} := \max(W_{H_{\min}(x)}, W_{S_{\min}(x)}, W_{\min})$$

$$W_{\min} = 8.491 \times 10^5 \text{ cm}^3$$

4.3.3 Moment of inertia

$$I_{\min} := 3 \cdot \left(\frac{L}{k}\right) \cdot W_{\min}$$

$$I_{\min} = 1.936 \times 10^8 \text{ cm}^4$$

W_d = actual modulus of ship crosssection at strength deck

W_b = actual modulus of ship crosssection at bottom

S_d = utilization factor of deck > 1

S_b = utilization factor of bottom > 1

$$W_d := 2703023.516 \text{ cm}^3$$

$$W_b := 1875524.476 \text{ cm}^3$$

$$S_d := \left(\frac{W_d}{W_{\min}}\right) = 3.183$$

$$S_b := \left(\frac{W_b}{W_{\min}}\right) = 2.209$$

4. 4 Shearing strenght

4.4.2 Calculation of shear stresses

I_y, F_s, F_w = according to 4.1.2

S = first moment, in [cm³], about the neutral axis, of the area of the effective longitudinal members between the vertical level at which the shear stress is being determined and the vertical extremity of effective longitudinal members, taken at the section under consideration;

t = thickness of side shell or longitudinal bulkhead plating, in [mm], at the section considered;

$\Phi = 0$ for ships without longitudinal bulkhead Where two longitudinal bulkhead are fitted:

If ship have 2 longitudinal bulkheads then -> long_blk=2

otherwise -> long_blk=0

$$\text{long_blk} := 2$$

$$S := 5324000 \text{ cm}^3$$

DODATAK A - Proračun u Mathcad programskom paketu

$$t := 7 \quad \text{mm}$$

A_s = sectional area of side shell plating, in [cm²], within the depth D

A_L = sectional area of longitudinal bulkhead plating, in [cm²], within the depth D

$$A_s := 1404 \quad \text{cm}^2$$

$$A_L := 364 \quad \text{cm}^2$$

F_s = shear force at considered section (+/-)

$$F_{s_positive} := 1569.6 \quad \text{kN (hogging)}$$

$$F_{s_negative} := -1569.6 \quad \text{kN (sagging)}$$

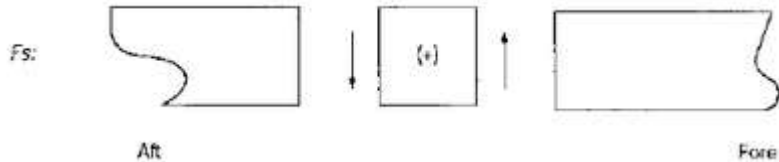

For the side shell:

$$\Phi_{ss} := 0.34 - 0.08 \cdot \left(\frac{A_s}{A_L} \right) = 0.031$$

For the longitudinal bulkhead

$$\Phi_{lb} := 0.16 + 0.08 \cdot \left(\frac{A_s}{A_L} \right) = 0.469$$

I_y = moment of inertia of the transversal section, in [cm⁴], around the horizontal axis;

$$I_y := 1.2069 \cdot 10^9 \quad \text{cm}^4$$

$$x := 54 \quad \text{m}$$

$$\tau_{ss_positive} := \left[\frac{(F_{s_positive} + F_{w_positive}(x)) \cdot S}{I_y \cdot t} \right] \cdot \left(0.5 - \begin{cases} \Phi_{ss} & \text{if long_blk} = 2 \\ 0 & \text{if long_blk} = 0 \end{cases} \right) \cdot 10^2$$

$$\tau_{ss_positive} = 170.061 \quad \text{N/mm}^2$$

$$\tau_{ss_negative} := \left[\frac{(F_{s_negative} + F_{w_negative}(x)) \cdot S}{I_y \cdot t} \right] \cdot \left(0.5 - \begin{cases} \Phi_{ss} & \text{if long_blk} = 2 \\ 0 & \text{if long_blk} = 0 \end{cases} \right) \cdot 10^2$$

$$\tau_{ss_negative} = -151.643 \quad \text{N/mm}^2$$

$$\tau_{lb_positive} := \begin{cases} \left[\frac{(F_{s_positive} + F_{w_positive}(x)) \cdot S}{I_y \cdot t} \right] \cdot (0.5 - \Phi_{lb}) \cdot 10^2 & \text{if long_blk} = 2 \\ 0 & \text{if long_blk} = 0 \end{cases}$$

$$\tau_{lb_positive} = 11.407 \quad \text{N/mm}^2$$

DODATAK A - Proračun u Mathcad programskom paketu

$$\tau_{lb_negative} := \begin{cases} \left[\frac{[(F_{s_negative} + F_{w_negative}(x)) \cdot S]}{I_y \cdot t} \right] \cdot (0.5 - \Phi_{lb}) \cdot 10^2 & \text{if } long_blk = 2 \\ 0 & \text{if } long_blk = 0 \end{cases}$$

$$\tau_{lb_negative} = -10.171 \quad \text{N/mm}^2$$

$$\tau_{permissible} := \left(\frac{110}{k} \right) = 110 \quad \text{N/mm}^2$$

DODATAK A - Proračun u Mathcad programskom paketu

5 Shell plating

5.1 General

5.1.1 The application of the design formulae given in 5.2.1.2 to ships of less than 90 m in length may be accepted by the *Register* when a proof of longitudinal strength has been carried out

If proof of longitudinal strength is carried out then \rightarrow long_strength=1
otherwise \rightarrow long_strength=0

$$\text{long_strength} := 1$$

5.1.2 Definitions

k = material factor according to 1.4.2.2;

p_B = load on bottom, in [kN/m²], according to 3.2.3;

p_S = load on sides, in [kN/m²], according to 3.2.2.1;

p_e = design pressure for the bow area, in [kN/m²], according to 3.2.2.2;

p_{SL} = design slamming pressure, in [kN/m²], according to 3.2.4;

$n_l = 1,0$, for transverse framing;

$n_l = 0,83$, for longitudinal framing;

W_d = actual section modulus at strength deck [cm³]

W_b = actual section modulus at bottom [cm³]

σ_L = maximum hull girder bending stress in [N/mm²] for calculating stress and for fatigue analysis at the considered station is given by the following formula:

$$M_{BH_SW} := 29430 \quad \text{kNm}$$

$$M_{BS_SW} := -29430 \quad \text{kNm}$$

$$M_{WH} := 6.956 \times 10^4 \quad \text{kNm}$$

$$M_{WS} := -8.172 \times 10^4 \quad \text{kNm}$$

$$M_{SL} := 0 \quad \text{kNm} \quad M_{SL}=0 \text{ if } M_B \text{ have 10\% addition on original } M_B \text{ curve from weight and buoyancy}$$

$$w_d := 1.8755 \cdot 10^6 \quad \text{cm}^3$$

$$w_b := 2.703 \cdot 10^6 \quad \text{cm}^3$$

$$\sigma_{L_b} := \left[\frac{(\max(|M_{BH_SW}|, |M_{BS_SW}|) + 0.75 \cdot \max(|M_{WH}|, |M_{WS}|) + |M_{SL}|)}{w_b} \right] \cdot 10^3$$

$$\sigma_{L_b} = 33.563 \quad \text{N/mm}^2$$

$$\sigma_{L_d} := \left[\frac{(\max(|M_{BH_SW}|, |M_{BS_SW}|) + 0.75 \cdot \max(|M_{WH}|, |M_{WS}|) + |M_{SL}|)}{w_d} \right] \cdot 10^3$$

$$\sigma_{L_d} = 48.371 \quad \text{N/mm}^2$$

DODATAK A - Proračun u Mathcad programskom paketu

τ_L = maximum design shear stress due to longitudinal hull girder bending, in [N/mm²], where the wave shear force may be taken as 0,75 F_w ;

σ_{dop} = permissible design stress in [N/mm²];

t_k = corrosion addition according to Section 2.9.1.; 1,5 mm, for $t \leq 10$ mm

$$\tau_{ss} := 31 \quad \text{N/mm}^2$$

k = material factor

$k = 0,78$, for steel with $ReH = 315$ N/mm²,

$k = 0,72$, for steel with $ReH = 355$ N/mm²,

$k = 0,66$, for steel with $ReH = 390$ N/mm² provided that a fatigue assessment of the structure is performed to verify compliance with the requirements of the *Register*,

$k = 0,68$, for steel with $ReH = 390$ N/mm² in other cases.

$$k := 1$$

$$\sigma_{dop} := \begin{cases} \left[\left(0,8 + \frac{L}{450} \right) \cdot \left(\frac{230}{k} \right) \right] & \text{if } L < 90 \\ \left(\frac{230}{k} \right) & \text{if } L \geq 90 \end{cases}$$

$$\sigma_{dop} = 222,844 \quad \text{N/mm}^2$$

5.2 Bottom plating

5.2.1 Plating within 0.4 L amidship

5.2.1.1 The thickness of the bottom plating of ships up to 90 m in length is not to be less than:

$$t_k := 1,5 \quad \text{mm}$$

$$n_1 := 0,83 \quad \begin{array}{l} n_l = 1,0, \text{ for transverse framing;} \\ n_l = 0,83, \text{ for longitudinal framing;} \end{array}$$

$$p_B := 40,31 \quad \text{kN/m}^2$$

$$s_w := 0,6 \quad \text{m}$$

$$t_{1_u90}(n_1, s, p_B, t_k) := \begin{cases} \left(1,9 \cdot n_1 \cdot s \cdot \sqrt{p_B \cdot k} + t_k \right) & \text{if } L \leq 90 \\ 0 & \text{if } L > 90 \end{cases}$$

$$t_{1_u90}(n_1, s, p_B, t_k) = 7,507 \quad \text{mm} \quad \text{CHOSEN THICKNESS: 9 mm}$$

5.2.1.2 The thickness of the bottom plating for ships of 90 m in length and more is not to be less than the following two values

(The application of the design formulae given in 5.2.1.2 to ships of less than 90 m in length may be accepted by the *Register* when a proof of longitudinal strength has been carried out):

$$\sigma_a := \sqrt{\sigma_{dop}^2 - 3 \cdot \left(\begin{cases} \tau_{ss} & \text{if long_strength} = 1 \\ 0 & \text{if long_strength} = 0 \end{cases} \right)^2} - 0,89 \cdot \left[\begin{array}{l} \sigma_{L_b} \text{ if long_strength} = 1 \\ \left(\left(12,6 \cdot \frac{\sqrt{L}}{k} \right) \right) \text{ if long_strength} = 0 \wedge L < 90 \\ \left(\left(\frac{120}{k} \right) \right) \text{ if long_strength} = 0 \wedge L \geq 90 \end{array} \right]$$

DODATAK A - Proračun u Mathcad programskom paketu

$$\sigma_a = 186.408 \quad \text{N/mm}^2$$

$$t_1 := \begin{cases} 0 & \text{if } \text{long_strength} = 0 \wedge L < 90 \\ \left(18.3 \cdot n_1 \cdot s \cdot \sqrt{\frac{p_B}{\sigma_a}} + t_k \right) & \text{if } \text{long_strength} = 1 \vee \text{long_strength} = 0 \wedge L \geq 90 \end{cases}$$

$$t_1 = 5.738 \quad \text{mm}$$

$$t_2 := \begin{cases} 0 & \text{if } \text{long_strength} = 0 \wedge L < 90 \\ \left(1.21 \cdot s \cdot \sqrt{p_B \cdot k} + t_k \right) & \text{if } \text{long_strength} = 1 \vee \text{long_strength} = 0 \wedge L \geq 90 \end{cases}$$

$$t_2 = 6.109 \quad \text{mm}$$

$$t_b(t_1, t_2) := \max(t_1, t_2)$$

$$t_b(t_1, t_2) = 6.109 \quad \text{mm}$$

5.2.2 Critical plate thickness

5.2.2.1 For ships, for which proof of longitudinal strength is carried out, the thickness is not to be less than thickness according to the following formula:

If is the bottom built in longitudinal system then -> long_framing=1

If is the bottom built in transverse system then -> long_framing=0

$$\text{long_framing} := 1$$

c = according to 4.6.2.1.1;

c = correction factor;

$c = 1,0$ for stiffeners sniped at both ends;

$c = 1,3$ when plating stiffened by floors or deep girders;

$c = 1,21$ when stiffeners are angles or T-sections;

$c = 1,10$ when stiffeners are bulb bars;

$c = 1,05$ when stiffeners are flat bars;

$$c := 1.1$$

α = aspect ratio of plate panel considered

s = stiffener's spacing, [m]

l = larger side of panel, [m]

$$s := 0.6 \quad \text{m}$$

$$l := 2.4 \quad \text{m}$$

$$\alpha := \frac{s}{l} = 0.25$$

$$c_1(\alpha, \text{long_framing}) := \begin{cases} 0.5 & \text{if } \text{long_framing} = 1 \\ \left[\frac{1}{(1 + \alpha^2) \cdot \sqrt{c}} \right] & \text{if } \text{long_framing} = 0 \end{cases}$$

$$t_{\text{crit}} := \begin{cases} \left(c_1(\alpha, \text{long_framing}) \cdot 2.32 \cdot s \cdot \sqrt{\sigma_{L_b}} + t_k \right) & \text{if } \text{long_strength} = 1 \\ 0 & \text{if } \text{long_strength} = 0 \end{cases}$$

DODATAK A - Proračun u Mathcad programskom paketu

$$t_{crit} = 5.532 \quad \text{mm}$$

$t_{b_min_admidship}$ = minimal bottom plating thickness

$$t_{b_min_admidship} := \begin{cases} \max(t_1, t_2, t_{crit}) & \text{if } (long_strength = 1 \wedge L < 90) \vee (long_strength = 0 \wedge L \geq 90) \\ t_{1_u90}(n_1, s, p_B, t_k) & \text{if } long_strength = 0 \wedge L < 90 \end{cases}$$

$$t_{b_min_admidship} = 6.109 \quad \text{mm}$$

5.2.4 Bilge strake

5.2.4.1 The thickness of the bilge strake is to be determined as required for the bottom plating according to 5.2.1. The thickness so determined is to be verified for sufficient buckling strength according to Section 4.6, see Table 4.6.2.1-3, load cases 1a, 1b, 2 and 4.

$$s := 0.6 \quad \text{m}$$

$$t_k := 1.5 \quad \text{mm}$$

$$n_1 := 0.83 \quad \begin{array}{l} n_l = 1,0, \text{ for transverse framing;} \\ n_l = 0,83, \text{ for longitudinal framing;} \end{array}$$

$$p_B := 40.31 \quad \text{kN/m}^2$$

$$s := 0.6 \quad \text{m}$$

$$t_{1_u90}(n_1, s, p_B, t_k) := \begin{cases} (1.9 \cdot n_1 \cdot s \cdot \sqrt{p_B \cdot k} + t_k) & \text{if } L \leq 90 \\ 0 & \text{if } L > 90 \end{cases}$$

$$t_{1_u90}(n_1, s, p_B, t_k) = 7.507 \quad \text{mm} \quad \text{CHOSEN THICKNESS: 9 mm}$$

(The application of the design formulae given in 5.2.1.2 to ships of less than 90 m in length may be accepted by the *Register* when a proof of longitudinal strength has been carried out):

$$\sigma_a(\sigma_{dop}, \tau_{ss}, \sigma_{L_b}, k) := \sqrt{\sigma_{dop}^2 - 3 \cdot \left(\begin{cases} \tau_{ss} & \text{if } long_strength = 1 \\ 0 & \text{if } long_strength = 0 \end{cases} \right)^2} - 0.89 \cdot \begin{cases} \sigma_{L_b} & \text{if } long_strength = 1 \\ \left(\left(\frac{12.6 \cdot \sqrt{L}}{k} \right) \right) & \text{if } long_strength = 0 \wedge L < 90 \\ \left(\left(\frac{120}{k} \right) \right) & \text{if } long_strength = 0 \wedge L \geq 90 \end{cases}$$

$$\sigma_a(\sigma_{dop}, \tau_{ss}, \sigma_{L_b}, k) = 186.408 \quad \text{N/mm}^2$$

$$t_1(n_1, s, p_B, \sigma_a, t_k) := \begin{cases} 0 & \text{if } long_strength = 0 \wedge L < 90 \\ \left(18.3 \cdot n_1 \cdot s \cdot \sqrt{\frac{p_B}{\sigma_a(\sigma_{dop}, \tau_{ss}, \sigma_{L_b}, k)}} + t_k \right) & \text{if } long_strength = 1 \vee long_strength = 0 \wedge L \geq 90 \end{cases}$$

$$t_1(n_1, s, p_B, \sigma_a, t_k) = 5.738 \quad \text{mm}$$

$$t_2(s, p_B, k, t_k) := \begin{cases} 0 & \text{if } long_strength = 0 \wedge L < 90 \\ (1.21 \cdot s \cdot \sqrt{p_B \cdot k} + t_k) & \text{if } long_strength = 1 \vee long_strength = 0 \wedge L \geq 90 \end{cases}$$

DODATAK A - Proračun u Mathcad programskom paketu

$$t_2(s, p_B, k, t_k) = 6.109 \quad \text{mm}$$



$$t_{\min_bilge_strake}(n_1, s, p_B, t_k, \sigma_a, k) := \begin{cases} t_{1_u90}(n_1, s, p_B, t_k) & \text{if } \text{long_strength} = 0 \wedge L < 90 \\ \max(t_1(n_1, s, p_B, \sigma_a, t_k), t_2(s, p_B, k, t_k)) & \text{if } (\text{long_strength} = 1 \wedge L < 90) \vee (\text{long_strength} = 0 \wedge L \geq 90) \end{cases}$$

$$t_{\min_bilge_strake}(n_1, s, p_B, t_k, \sigma_a, k) = 6.109 \quad \text{mm}$$

CHOSEN THICKNESS: 9 mm

5.2.5 Flat plate keel and garboard strake

5.2.5.1 The width of the flat plate keel is not to be less than:

$$b_{\text{flat_plate_keel}} := \min(500 + 5 \cdot L, 1800) = 880 \quad \text{mm}$$

The thickness of the flat plate keel within $0,7 L$ amidships is not to be less than:

$$t_{KB} := t_{b_min_amidship} + 2 = 8.109 \quad \text{mm} \quad \text{CHOSEN THICKNESS: 10,5 mm}$$

5.2.5.2 Where a bar keel is arranged, the adjacent garboard strake is to have the scantling of a flat plate keel.

5.2.6 Minimum thickness

At no point the thickness of the bottom shell plating is to be less than:

$$t_{\min} := \begin{cases} \min[(1.5 - 0.01 \cdot L) \cdot \sqrt{L \cdot k}, 16] & \text{if } L < 50 \\ \min(\sqrt{L \cdot k}, 16) & \text{if } L \geq 50 \end{cases}$$

$$t_{\min} = 8.718 \quad \text{mm}$$

CHOSEN THICKNESS: 9 mm

5.3 SIDE SHELL PLATING

5.3.1 Side shell plating within 0,4 L amidships

$$p_{\text{max}} := 35.24 \quad \text{kN/m}^2$$

$$s_w := 0.6 \quad \text{m}$$

$$t_{\text{kev}} := 1.5 \quad \text{mm}$$

$$n_1 := 0.83 \quad \begin{array}{l} n_l = 1,0, \text{ for transverse framing;} \\ n_l = 0,83, \text{ for longitudinal framing;} \end{array}$$

$$\sigma_{LS}(\sigma_{L_b}, \sigma_{L_d}) := 0.76 \cdot \max(\sigma_{L_b}, \sigma_{L_d})$$

$$\tau_L(\tau_{ss}) := \tau_{ss}$$

$$\tau_L(\tau_{ss}) = 31$$

$$\sigma_{\text{dop}}(\sigma_{\text{dop}}, \tau_L, \sigma_{LS}) := \sqrt{\sigma_{\text{dop}}^2 - 3 \cdot \tau_L(\tau_{ss})^2} - 0.89 \cdot \sigma_{LS}(\sigma_{L_b}, \sigma_{L_d})$$

$$\sigma_a(\sigma_{\text{dop}}, \tau_L, \sigma_{LS}) = 183.561$$

DODATAK A - Proračun u Mathcad programskom paketu

$$t_s(n_1, s, p_{s_s}, k, t_k, \sigma_a) := \begin{cases} (1.9 \cdot n_1 \cdot s \cdot \sqrt{p_{s_s} \cdot k} + t_k) & \text{if } L < 90 \\ \max \left[18.3 \cdot n_1 \cdot s \cdot \sqrt{\left(\frac{p_{s_s}}{\sigma_a (\sigma_{dop}, \tau_L, \sigma_{LS})} \right)} + t_k, 1.21 \cdot s \cdot \sqrt{p_{s_s} \cdot k} + t_k \right] & \text{if } L \geq 90 \end{cases}$$

$$t_s(n_1, s, p_{s_s}, k, t_k, \sigma_a) = 7.117 \quad \text{mm} \quad \text{CHOSEN THICKNESS: 8,5 mm}$$

Side shell plating for transverse framing;

$$p_{s_s} := 27.634 \quad \text{kN/m}^2 \quad s := 0.6 \quad \text{m} \quad t_k := 1.5 \quad \text{mm} \quad n_{10.1} 1$$

$$t_s(n_1, s, p_{s_s}, k, t_k, \sigma_a) = 7.493 \quad \text{mm} \quad \text{CHOSEN THICKNESS: 8,5 mm}$$

5.3.3 Minimum thickness

For the minimum thickness of the side shell plating 5.2.6 applies accordingly.

$$t_{\min_s} := \begin{cases} \min[(1.5 - 0.01 \cdot L) \cdot \sqrt{L \cdot k}, 16] & \text{if } L < 50 \\ \min(\sqrt{L \cdot k}, 16) & \text{if } L \geq 50 \end{cases}$$

$$t_{\min_s} = 8.718 \quad \text{mm} \quad \text{CHOSEN THICKNESS: 8,5 mm}$$

Above a level $d + C_w/2$ above base line smaller thicknesses than t_{\min} may be accepted if the stress level permits such reduction.

$C_w =$ according to 4.2.2

$$C_w := 7.397$$

$$d + \left(\frac{C_w}{2} \right) = 6.399 \quad \text{m}$$

5.3.4 Sheerstrake

5.3.4.1 The width of the sheerstrake is not to be less than:

$$b_{\text{sheerstrake}} := \min(800 + 5 \cdot L, 1800)$$

$$b_{\text{sheerstrake}} = 1.18 \times 10^3 \quad \text{mm} \quad \text{CHOSEN WIDTH: 1200 mm}$$

5.3.4.2 The thickness of the sheer strake within $0,4 L$ amidships

$t_s =$ thickness in [mm] of sides shell

$t_d =$ thickness in [mm] of adjenced deck

$$t_s := 8.5 \quad \text{mm}$$

$$t_d := 7 \quad \text{mm}$$

$$t_{\text{sheerstrake}} := \max[t_s, 0.5 \cdot (t_s + t_d)]$$

$$t_{\text{sheerstrake}} = 8.5 \quad \text{mm} \quad \text{CHOSEN THICKNESS: 8,5 mm}$$

DODATAK A - Proračun u Mathcad programskom paketu

6 DECKS

6.1 STRENGTH DECK

Minimum deck thickness (L need not to be grater than 200m)

$$t_{\min}(k) := (4.5 + 0.05 \cdot L) \cdot \sqrt{k}$$

For AH36 Steel Decks (Decks 2 and 3):

$$k := 0.72$$

$$t_{\min}(k) = 7.043 \text{ mm}$$

For Mild Steel Decks (All Decks except Deck 2 and Deck 3):

$$k := 1$$

$$t_{\min}(k) = 8.3 \text{ mm}$$

6.2 LOWER DECKS

6.2.2 Thickness of decks for wheel loading

A - area of plate panel u · v according to Fig. 6.2.2.1

$$A(u, v) := \min(u \cdot v, 2.5 \cdot v^2)$$

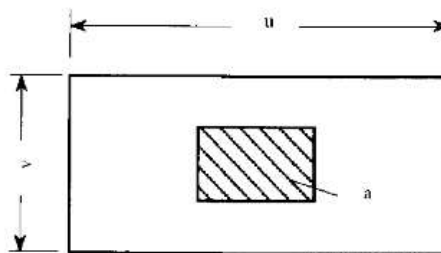

Figure 6.2.2.1

P - load, in [kN], of one wheel or group of wheels on a plate panel

$$P(Q, n) := \frac{Q}{n}$$

Q - axle load in [kN]

n - number of wheels (or group of wheels) per axle.

a_{unkn} [m²] - Where the wheel print area is not known, it may approximately be determined as follows:

$$a_{\text{unkn}}(Q, n, p) := 100 \cdot \frac{P(Q, n)}{p \cdot 10^4}$$

p = specific wheel pressure according to Table 6.2.2.2

Table 6.2.2.2

Type of vehicle	Specific wheel pressure p [bar]	
	Pnumatic tyres	Solid rubber tyres
private cars	2	–
trucks	8	–
trailer	8	15
fork lift trucks	6	15

a [m²] - Calculation will take into account lesser than two:

DODATAK A - Proračun u Mathcad programskom paketu

$$a(Q, n, p, a_{kn}) := \begin{cases} a_{\text{unkn}}(Q, n, p) & \text{if } a_{kn} = 0 \\ \min(a_{\text{unkn}}(Q, n, p), a_{kn}) & \text{if } a_{kn} \neq 0 \end{cases}$$

c_{wheel} - factor according to the following formulae:

$$c_{11}(u, v, Q, n, p, a_{kn}) := 1.87 - \sqrt{3.4 - \left(4.4 \cdot \frac{a(Q, n, p, a_{kn})}{A(u, v)}\right)}$$

$$c_{12}(u, v, Q, n, p, a_{kn}) := 1.2 - \left(0.4 \cdot \frac{a(Q, n, p, a_{kn})}{A(u, v)}\right)$$

$$c_{21}(u, v, Q, n, p, a_{kn}) := 2.00 - \sqrt{\frac{a(Q, n, p, a_{kn})}{A(u, v)} \cdot \left[5.4 - \left(7.2 \cdot \frac{a(Q, n, p, a_{kn})}{A(u, v)}\right)\right]}$$

$$c_{22}(u, v, Q, n, p, a_{kn}) := 1.2 - \left(0.517 \cdot \frac{a(Q, n, p, a_{kn})}{A(u, v)}\right)$$



$$c_{\text{wheel}}(u, v, Q, n, p, a_{kn}) := \begin{cases} c_{11}(u, v, Q, n, p, a_{kn}) & \text{if } \frac{a(Q, n, p, a_{kn})}{A(u, v)} < 0.3 \wedge \frac{u}{v} = 1 \\ c_{12}(u, v, Q, n, p, a_{kn}) & \text{if } \frac{a(Q, n, p, a_{kn})}{A(u, v)} \geq 0.3 \wedge \frac{u}{v} = 1 \\ c_{21}(u, v, Q, n, p, a_{kn}) & \text{if } \frac{a(Q, n, p, a_{kn})}{A(u, v)} < 0.3 \wedge \frac{u}{v} \geq 2.5 \\ c_{22}(u, v, Q, n, p, a_{kn}) & \text{if } \frac{a(Q, n, p, a_{kn})}{A(u, v)} \geq 0.3 \wedge \frac{u}{v} \geq 2.5 \\ \left[\left(c_{21}(u, v, Q, n, p, a_{kn}) - c_{11}(u, v, Q, n, p, a_{kn}) \right) \left[\frac{\left(\frac{u}{v} - 1 \right)}{1.5} \right] \right] + c_{11}(u, v, Q, n, p, a_{kn}) & \text{if } \frac{a(Q, n, p, a_{kn})}{A(u, v)} < 0.3 \wedge 1 < \frac{u}{v} < 2.5 \\ \left[\left(c_{22}(u, v, Q, n, p, a_{kn}) - c_{12}(u, v, Q, n, p, a_{kn}) \right) \left[\frac{\left(\frac{u}{v} - 1 \right)}{1.5} \right] \right] + c_{12}(u, v, Q, n, p, a_{kn}) & \text{if } \frac{a(Q, n, p, a_{kn})}{A(u, v)} \geq 0.3 \wedge 1 < \frac{u}{v} < 2.5 \end{cases}$$

t_{wheel} [mm]- the thickness of deck plating for wheel loading

$$t_{\text{wheel}}(Q, n, a_v, t_k, u, v, p, a_{kn}) := c_{\text{wheel}}(u, v, Q, n, p, a_{kn}) \cdot \sqrt{P(Q, n) \cdot (1 + a_v) \cdot k} + t_k$$

DECK 2

$$a_v := 0.5 \quad Q := 120 \quad n := 2 \quad t_k := 1 \quad u := 2.4 \quad v := 0.6 \quad a_{kn} := 0$$

$$p := 8$$

$$t_{\text{wheel}}(Q, n, a_v, t_k, u, v, p, a_{kn}) = 13.974 \quad \text{mm} \quad \text{CHOSEN THICKNESS: 14 mm}$$

DECK 1

$$a_v := 0.5 \quad Q := 20 \quad n := 2 \quad t_k := 1 \quad u := 2.4 \quad v := 0.6 \quad a_{kn} := 0$$

$$p := 8$$

$$t_{\text{wheel}}(Q, n, a_v, t_k, u, v, p, a_{kn}) = 7.695 \quad \text{mm} \quad \text{CHOSEN THICKNESS: 8 mm}$$

DODATAK A - Proračun u Mathcad programskom paketu

Thickness of decks in accomodation decks

DECK 6, DECK 5, DECK 4

$$t_{\text{MandA}}(s, p, t_k) := \max(1.1 \cdot s \cdot \sqrt{p \cdot k} + t_k, 5)$$

$$s := 0.6 \quad p := 4.03 \quad t_k := 1.5$$

$$t_{\text{MandA}}(s, p, t_k) = 5 \quad \text{mm}$$

CHOSEN THICKNESS: 7 mm

Thickness of decks in machinery decks

$$s := 0.6 \quad p := 9.211 \quad t_k := 1.5$$

$$t_{\text{MandA}}(s, p, t_k) = 5 \quad \text{mm}$$

CHOSEN THICKNESS: 7 mm

7 BOTTOM STRUCTURES

7.2 DOUBLE BOTTOM

7.2.1 General

7.2.1.9 Double bottoms in passenger ships and cargo ships other than tankers

7.2.1.9.2 Where a double bottom is required to be fitted the inner bottom shall be continued out to the ship's sides in such a manner as to protect the bottom to the turn of the bilge.

Such protection will be deemed satisfactory if the inner bottom is not lower at any part than a plane parallel with the keel line and which is located not less than a vertical distance h measured from the keel line, as calculated by the formula:

$$h_{db_min} := \min \left[\max \left[\left(\frac{B}{20} \right) \cdot 1000, 760 \right], 2000 \right] = 900 \text{ mm}$$

7.2.2 Centre girder

7.2.2.2 Scantlings

a) The depth of the centre girder is not to be less than:

If is longitudinal wing bulkhead fitted than \rightarrow long_wing=1

If not than \rightarrow long_wing=0

$$\text{long_wing} := 0$$

$B_{\text{between_long_wing}}$ = distance between longitudinal wing bulkheads [m]

$$B_{\text{between_long_wing}} := 12$$

$$B_{\text{hdb}}(B_{\text{between_long_wing}}, \text{long_wing}) := \begin{cases} \max(B_{\text{between_long_wing}}, 0.8B) & \text{if long_wing} = 1 \\ B & \text{if long_wing} = 0 \end{cases}$$

$$h_{\text{db}}(B_{\text{hdb}}, B_{\text{between_long_wing}}, \text{long_wing}) := \max(350 + 45 \cdot B_{\text{hdb}}(B_{\text{between_long_wing}}, \text{long_wing}), 600)$$

$$h_{\text{db}}(B_{\text{hdb}}, B_{\text{between_long_wing}}, \text{long_wing}) = 1.16 \times 10^3 \text{ mm}$$

b) The thickness of the centre girder is not be less than:

h_a = height of center girder as built

$$h_a := 2200 \text{ mm}$$

$$k := 1$$



DODATAK A - Proračun u Mathcad programskom paketu

$$t_{cg_db}(h_{db}, B_{hdb}, B_{between_long_wing}, long_wing, h_a, k) :=$$

$$\left(\frac{h_{db}(B_{hdb}, B_{between_long_wing}, long_wing)}{h_a} \right) \cdot \left[\left(\frac{h_{db}(B_{hdb}, B_{between_long_wing}, long_wing)}{100} \right) + 1 \right] \cdot \sqrt{k} \text{ if } h_{db}(B_{hdb}, B_{between_long_wing}, long_wing) \leq 1200$$

$$\left(\frac{h_{db}(B_{hdb}, B_{between_long_wing}, long_wing)}{h_a} \right) \cdot \left[\left(\frac{h_{db}(B_{hdb}, B_{between_long_wing}, long_wing)}{120} \right) + 3 \right] \cdot \sqrt{k} \text{ if } h_{db}(B_{hdb}, B_{between_long_wing}, long_wing) > 1200$$

$$t_{cg_db}(h_{db}, B_{hdb}, B_{between_long_wing}, long_wing, h_a, k) = 6.644 \quad \text{mm}$$

In 0.15 L at ends of length L thickness of the center girder can be reduced:

$$t_{1cg_db}(t_{cg_db}) := 0.9 \cdot t_{cg_db}(h_{db}, B_{hdb}, B_{between_long_wing}, long_wing, h_a, k)$$

$$long_wing := 0 \quad B_{between_long_wing} := 10 \quad h_a := 2200 \quad k := 1$$

$$t_{cg_db}(h_{db}, B_{hdb}, B_{between_long_wing}, long_wing, h_a, k) = 6.644$$

$$t_{1cg_db}(t_{cg_db}) = 5.979 \quad \text{CHOSEN SIZE:1200X8 mm}$$

7.2.3 Side girders

7.2.3.2 Scantlings

7.2.3.2.1 The thickness of the side girders is not to be less than:

$$t_{sg_db}(h_{db}, B_{hdb}, B_{between_long_wing}, long_wing, h_a, k) := \left(\frac{h_{db}(B_{hdb}, B_{between_long_wing}, long_wing)^2}{120 \cdot h_a} \right) \cdot \sqrt{k}$$

$$long_wing := 1 \quad B_{between_long_wing} := 10 \quad h_a := 1920 \quad k := 1$$

$$t_{sg_db}(h_{db}, B_{hdb}, B_{between_long_wing}, long_wing, h_a, k) = 4.323 \quad \text{mm} \quad \text{CHOSEN SIZE:1200X7 mm}$$

7.2.4 Inner bottom

7.2.4.1 The thickness of the inner bottom plating is not to be less than:

p = design pressure in [kN/m²].

p is the greater of the following values:

$$p_1 = 10 (d - h_{db})$$

$$p_2 = 10 \times h, \text{ where the inner bottom forms a tank boundary}$$

$$p_3 = p_{DB} \text{ according to Section 3.3.2.1;}$$

h = distance from top of overflow pipe to inner bottom, in [m];

h_{db} = double bottom height, in [m]

DODATAK A - Proračun u Mathcad programskom paketu

$$p_{in_p} := 46.2 \text{ kN/m}^2$$

$$s := 0.6 \text{ m}$$

$$t_k := 1.5 \text{ mm}$$

$$t_{ib}(s, p_{in_p}, t_k, k) := 1.1 \cdot s \cdot \sqrt{p_{in_p} \cdot k} + t_k \quad \text{mm}$$

$$p_{in_p} := 46.2 \text{ kN/m}^2 \quad s := 0.6 \text{ m} \quad t_k := 1.5 \text{ mm} \quad k := 1$$

$$t_{ib}(s, p_{in_p}, t_k, k) = 5.986 \text{ mm} \quad \text{CHOSEN THICKNESS: 8 mm}$$

7.2.4.2 If no ceiling is fitted on the inner bottom, the thickness determined in accordance with 7.2.4.1 for p1 or p2 is to be increased by 2 mm. This increase is not required for container ships.

7.2.6 Double bottom, transverse framing system

7.2.6.1 Plate floors

7.2.6.2 Scantlings

7.2.6.2.1 The thickness of plate floors is not to be less than:



$$t_{pf}(t_{cg_db}, h_{db}, B_{hdb}, B_{between_long_wing}, long_wing, h_a, k) := \min(t_{cg_db}(h_{db}, B_{hdb}, B_{between_long_wing}, long_wing, h_a, k) - 2, 16)$$

7.2.6.2.2 The sectional area of the plate floors is not to be less than:

$l = B$, if longitudinal bulkheads are not fitted;

b_1 = distance between supporting point of the plate floor (ship's side, longitudinal bulkhead) and the section considered, in [m]. The distance b_1 is not to be taken greater than $0.4 \times l$;

$f_1 = 0,5$ for spaces which may be empty at full draught, e.g. machinery spaces, storerooms, etc.;

$f_1 = 0,3$ elsewhere;

s = spacing of plate floors, in [m];

If longitudinal bulkhead is fitted than \rightarrow long_blk=1

otherwise \rightarrow long_blk=0

$$long_blk := 0$$

$$l_1 := 10 \text{ m}$$

$$f_1 := 0.5$$

$$b_1 := 0 \text{ m}$$

$$k := 1$$

$$s := 1 \text{ m}$$

DODATAK A - Proračun u Mathcad programskom paketu

$$l(l_1) := \begin{cases} l_1 & \text{if long_blk} = 1 \\ B & \text{if long_blk} = 0 \end{cases}$$

$$A_w(f_1, l, l_1, b_1, k, s) := f_1 \cdot d \cdot l(l_1) \cdot s \cdot \left[1 - 2 \cdot \left(\frac{b_1}{l(l_1)} \right) \cdot k \right] \quad \text{cm}^2$$

$$s := 1 \quad \text{m} \quad k := 1 \quad l_1 := 10 \quad \text{m} \quad \text{long_blk} := 0 \quad f_1 := 0.5 \quad b_1 := 0 \quad \text{m}$$

$$A_w(f_1, l, l_1, b_1, k, s) = 24.3 \quad \text{cm}^2$$

CHOSEN PLATE FL.: 1200x6 mm

$$t_{pf}(t_{cg_db}, h_{db}, B_{hdb}, B_{\text{between_long_wing}}, \text{long_wing}, h_a, k) = 3.707 \quad \text{mm}$$

7.2.6.3 Bracket floors

7.2.6.3.3 The section modulus of bottom and inner bottom frames is not to be less than:

$$p := 48 \quad \text{kN/m}^2$$

$$e := 0.7$$

If there is struts than -> struts=1
otherwise -> struts=0

$$\text{struts} := 0$$

$$f_2(\text{struts}) := \begin{cases} 0.6 & \text{if struts} = 1 \\ 1 & \text{if struts} = 0 \end{cases}$$

$$s := 0.6 \quad \text{m}$$

$$l := 5 \quad \text{m}$$

$$k := 1$$

$$W_{bf}(e, f_2, \text{struts}, s, l, p, k) := e \cdot f_2(\text{struts}) \cdot s \cdot l^2 \cdot p \cdot k \quad \text{cm}^2$$

$$p := 48 \quad \text{kN/m}^2 \quad e := 0.7 \quad \text{struts} := 0 \quad s := 0.6 \quad \text{m} \quad l := 5 \quad \text{m} \quad k := 1$$

$$W_{bf}(e, f_2, \text{struts}, s, l, p, k) = 504 \quad \text{cm}^2$$

CHOSEN PROFILE: HP 180X8

7.2.7.5 Longitudinal girder system

7.2.7.5.1 Where longitudinal girders are fitted instead of bottom longitudinals, the spacing of floors may be greater than permitted by 7.3.1, provided that adequate strength of the structure is proved.

7.2.7.5.2 The plate thickness of the longitudinal girders is not to be less than:

$$k := 1$$

$$t := \max[(5 + 0.03 \cdot L) \cdot \sqrt{k}, 6 \cdot \sqrt{k}]$$

$$t = 7.28 \quad \text{mm}$$

CHOSEN THICKNESS: 7.5 mm

8 FRAMING

8.1 TRANSVERSE FRAMING

8.1.2 Main frames

8.1.2.1 Scantlings

$$n_{mf} := \begin{cases} (0.9 - 0.0035 \cdot L) & \text{if } L < 100 \\ 0.55 & \text{if } L \geq 100 \end{cases}$$

$$c_{mf}(l_{k1}, l_{k2}) := \max[1.0 - [l_{k1} + (0.45 \cdot l_{k2})], 0.65]$$

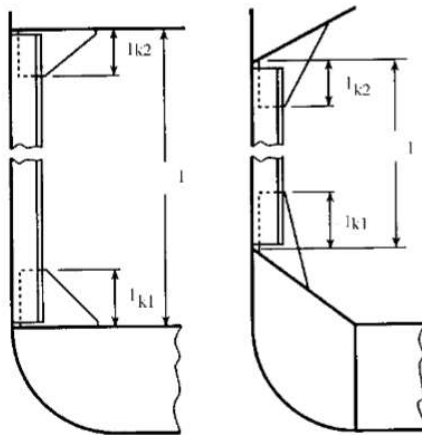

Figure 8.1.2

$$f(e_c, l) := \max\left[1, 0 - \left(2 \cdot \frac{e_c}{l}\right), 0.75\right]$$

f - factor for curved frames;
 $f_{min} = 0.75$;
 e - max. height of curve, in [m].

Min. section modulus of Main frame

$$W_{mf_min}(l_{k1}, l_{k2}, p_s, e_c, l, k) := n_{mf} \cdot c_{mf}(l_{k1}, l_{k2}) \cdot s \cdot l^2 \cdot p_s \cdot f(e_c, l) \cdot k$$

p_s - load on ship's sides, in [kN/m²], according to 3.2.2

Frames in tanks

$$W_1(l_{k1}, l_{k2}, p_s, e_c, l, p_1, k) := n_{mf} \cdot c_{mf}(l_{k1}, l_{k2}) \cdot s \cdot l^2 \cdot p_1 \cdot f(e_c, l) \cdot k$$

p_1 - pressure in [kN/m²], according to 3.4.1

$$W_2(s, l, p_2, k) := 0.44 \cdot s \cdot l^2 \cdot p_2 \cdot k \quad \text{acc to 11.2.3.1:}$$

p_2 - max static design pressure, according to 3.4.1.2



DODATAK A - Proračun u Mathcad programskom paketu

Main frame section modulus

$$W_{mf}(l_{k1}, l_{k2}, p_s, e_c, l, p_1, k) := \max(W_{mf_min}(l_{k1}, l_{k2}, p_s, e_c, l, k), W_1(l_{k1}, l_{k2}, p_s, e_c, l, p_1, k), W_1(l_{k1}, l_{k2}, p_s, e_c, l, p_1, k))$$

8.1.2.1.4 Where the scantlings of the main frames are determined by strength calculations, the following permissible stresses are to be observed:

- bending stress:

$$\sigma(k) := \frac{150}{k}$$

for k=1 $k := 1$ $\sigma(k) = 150$ N/mm²

for k=0.72 $k := 0.72$ $\sigma(k) = 208.333$ N/mm²

- shear stress:

$$\tau(k) := \frac{100}{k}$$

for k=1 $k := 1$ $\tau(k) = 100$ N/mm²

for k=0.72 $k := 0.72$ $\tau(k) = 138.889$ N/mm²

- equivalent stress:

$$\sigma_{ekv}(k) := \frac{180}{k}$$

for k=1 $k := 1$ $\sigma_{ekv}(k) = 180$ N/mm²

for k=0.72 $k := 0.72$ $\sigma_{ekv}(k) = 250$ N/mm²

MAIN FRAMES (Deck 1 - Deck 2)

$$s := 0.6 \quad l := 2.7 \quad p_1 := 0 \quad p_2 := 0 \quad e_c := 0 \quad p_s := 24.535$$

$$l_{k1} := 250 \quad l_{k2} := 250 \quad k := 1$$

$$W_{mf}(l_{k1}, l_{k2}, p_s, e_c, l, p_1, k) = 73.708 s$$

CHOSEN SIZE: HP160 x 8



DODATAK A - Proračun u Mathcad programskom paketu

8.1.3 Tween deck and Superstructure frames

Min. section modulus

$$p_{\min}(p_L, b, l) := 0.4 \cdot p_L \cdot \left(\frac{b}{l}\right)^2$$

p_L - tween deck load, in [kN/m²], acc. to 3.3.1

b - unsupported span of the deck beam below the respective 'tween deck frame, in [m].

$$p_{td}(p_S, p_L, b, l) := \max(p_{\min}(p_L, b, l), p_S)$$

p_S - load on ship's sides, in [kN/m²], according to 3.2.2

$$W_{td_min}(s, l, p_S, p_L, e_c, b) := 0.55 \cdot s \cdot l^2 \cdot p_{td}(p_S, p_L, b, l) \cdot f(e_c, l) \cdot k$$

For "tween" deck frames connected at their lower ends to the deck transverses, p_{\min} is to be multiplied by the factor:

$$f_1(s, S) := 0.75 + \left[0.25 \left(\frac{S}{s}\right)\right]$$

DECK 1

$$s := 0.6 \quad l := 3 \quad p_L := 17.087 \quad e_c := 0 \quad p_S := 30.68 \quad S := 2.4 \quad b := 1.2$$

$$W_{td_min}(s, l, p_S, p_L, e_c, b) = 91.12$$

CHOSEN SIZE: HP160 x 8

DECK 2

$$s := 0.6 \quad l := 3 \quad p_L := 17.087 \quad e_c := 0 \quad p_S := 21.226 \quad S := 2.4 \quad b := 1.2$$

$$W_{td_min}(s, l, p_S, p_L, e_c, b) = 63.041$$

CHOSEN SIZE: L 150 x 90 x 9

DECK 3

$$s := 0.6 \quad l := 3 \quad p_L := 17.087 \quad e_c := 0 \quad p_S := 12.717 \quad S := 2.4 \quad b := 1.2$$

$$W_{td_min}(s, l, p_S, p_L, e_c, b) = 37.769$$

CHOSEN SIZE: L 150 x 90 x 9

DECK 4

$$s := 0.6 \quad l := 3 \quad p_L := 4.03 \quad e_c := 0 \quad p_S := 10.91 \quad S := 2.4 \quad b := 1.2$$

$$W_{td_min}(s, l, p_S, p_L, e_c, b) = 32.403$$

CHOSEN SIZE: L 75 x 50 x 7

DODATAK A - Proračun u Mathcad programskom paketu

8.2 BOTTOM, SIDE AND DECK LONGITUDINALS, SIDE TRANSVERSES

p - load, in [kN/m²];

= p_B according to 3.2.3 for bottom longitudinals.

= p_s according to 3.2.2 for side longitudinals

= p₁ according to 3.4.1, for longitudinals at decks and at ship's sides,, at longitudinal bulkheads and inner bottom in way of tanks.

For bottom longitudinals in way of tanks p is not to be taken less than [kN/m²]:

$$P_{\text{bott_min}}(P_1, P_0, d_{\text{min}}, C_F) := P_1 - [(10 \cdot d_{\text{min}}) - (P_0 \cdot C_F)]$$

For side longitudinals below d_{min} p need not to be taken larger than [kN/m²]:

$$P_{\text{side_subd1}}(P_1, P_0, d_{\text{min}}, z, C_F) := P_1 - \left[10 \cdot (d_{\text{min}} - z) - P_0 \cdot C_F \cdot \left(1 + \frac{z}{d_{\text{min}}} \right) \right]$$

= p_d according to 3.4.2 for side and deck longitudinals as well as for horizontal stiffeners of longitudinal bulkheads in tanks which may be partially filled;

= p_D according to 3.2.1 for deck longitudinals of the strength deck;

= p_{DB} according to 3.3.2 for inner bottom longitudinals, however, not less than the load corresponding to the distance between inner bottom and deepest load waterline;

= p_L according to 3.3.1 for longitudinals of cargo decks and for inner bottom longitudinals;

8.2.3 Scantlings

8.2.3.1 Section modulus and shear area of longitudinals and longitudinal beams of the Strength deck

$$m_1(l, l_k, \alpha_k) := 1 - \left(\frac{l_k}{l} \cdot \sin(\alpha_k) \right)^2$$

$$m_2(l, s) := 0.204 \cdot \frac{s}{l} \cdot \left[4 - \left(\frac{s}{l} \right)^2 \right]$$

$$m(l, s, l_k, \alpha_k) := \left(m_1(l, l_k, \alpha_k) \right)^2 - m_2(l, s)^2$$

$$\sigma_t := \min \left[\left[0.8 + \left(\frac{L}{450} \right) \right] \cdot \frac{230}{k}, \frac{230}{k} \right]$$

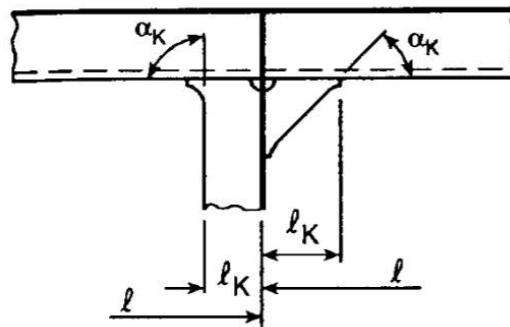

Figure 8.2.2

Allowable stress:

$$\sigma_{\text{dop}}(\sigma_B, \sigma_D, z, h_n) := \begin{cases} \min \left[\sigma_t + \sigma_B - \left[z \cdot \frac{(\sigma_B + \sigma_D)}{D} \right], \frac{150}{k} \right] & \text{if } z > h_n \\ \min \left[\sigma_t - \sigma_B + \left[z \cdot \frac{(\sigma_B + \sigma_D)}{D} \right], \frac{150}{k} \right] & \text{if } z \leq h_n \end{cases}$$

DODATAK A - Proračun u Mathcad programskom paketu

h_n - Position of the neutral axis above the vessel base line [cm²]:

Section modulus [cm³]:

$$W_{I1}(\sigma_B, \sigma_D, z, l, s, l_k, \alpha_k, p, h_n) := \frac{83.3}{\sigma_{dop}(\sigma_B, \sigma_D, z, h_n)} \cdot m(l, s, l_k, \alpha_k) \cdot s \cdot l^2 \cdot p$$

$$W_{I2}(l, s, p_2) := 0.44 \cdot s \cdot l^2 \cdot p_2 \cdot k$$

$$W_I(\sigma_B, \sigma_D, z, l, s, l_k, \alpha_k, p, p_2, h_n) := \max(W_{I1}(\sigma_B, \sigma_D, z, l, s, l_k, \alpha_k, p, h_n), W_{I2}(l, s, p_2))$$

Shear area [cm²]:

$$A_1(l, s, p) := [1 - (0.817 \cdot m_2(l, s))] \cdot 0.05 \cdot s \cdot l \cdot p \cdot k$$

DECK 1

$$\alpha_k := 45 \quad l_k := 0.15 \quad l := 2.4 \quad \sigma_B := 24.15 \quad \sigma_D := 30.19 \quad z := 2.2 \quad p := 40.31 \quad p_2 := 29.454$$

$$h_n := 4.465$$

$$W_I(\sigma_B, \sigma_D, z, l, s, l_k, \alpha_k, p, p_2, h_n) = 67.401$$

$$A_1(l, s, p) = 2.426$$

CHOSEN SIZE: HP160 x 8

DECK 2

$$\alpha_k := 45 \quad l_k := 0.15 \quad l := 2.4 \quad \sigma_B := 34.81 \quad \sigma_D := 43.51 \quad z := 4.9 \quad p := 40.31 \quad p_2 := 29.454$$

$$h_n := 4.465$$

$$W_I(\sigma_B, \sigma_D, z, l, s, l_k, \alpha_k, p, p_2, h_n) = 67.401$$

$$A_1(l, s, p) = 2.426$$

CHOSEN SIZE: HP200 x 9

DECK 3

$$\alpha_k := 45 \quad l_k := 0.15 \quad l := 2.4 \quad \sigma_B := 34.81 \quad \sigma_D := 43.51 \quad z := 8.1 \quad p := 4.03 \quad p_2 := 29.454$$

$$h_n := 4.465$$

$$W_I(\sigma_B, \sigma_D, z, l, s, l_k, \alpha_k, p, p_2, h_n) = 44.789$$

$$A_1(l, s, p) = 0.243$$

CHOSEN SIZE: L 100 x 50 x 7

DODATAK A - Proračun u Mathcad programskom paketu

DECK 4

$$\alpha_k := 45 \quad l_k := 0.15 \quad l := 2.4 \quad \sigma_B := 34.81 \quad \sigma_D := 43.51 \quad z := 10.9 \quad p := 4.03 \quad p_2 := 29.454$$

$$h := 4.465$$

$$W_1(\sigma_B, \sigma_D, z, l, s, l_k, \alpha_k, p, p_2, h_n) = 44.789$$

$$A_1(l, s, p) = 0.243$$

CHOSEN SIZE: L 100 x 50 x 7

DECK 5

$$\alpha_k := 45 \quad l_k := 0.15 \quad l := 2.4 \quad \sigma_B := 34.81 \quad \sigma_D := 43.51 \quad z := 13.7 \quad p := 4.03 \quad p_2 := 13.581$$

$$h := 4.465$$

$$W_1(\sigma_B, \sigma_D, z, l, s, l_k, \alpha_k, p, p_2, h_n) = 26.133$$

$$A_1(l, s, p) = 0.243$$

CHOSEN SIZE: L 75 x 50 x 7

DECK 6

$$\alpha_k := 45 \quad l_k := 0.15 \quad l := 2.4 \quad \sigma_B := 34.81 \quad \sigma_D := 43.51 \quad z := 14.9 \quad p := 4.03 \quad p_2 := 13.581$$

$$h := 4.465$$

$$W_1(\sigma_B, \sigma_D, z, l, s, l_k, \alpha_k, p, p_2, h_n) = 51.84$$

$$A_1(l, s, p) = 0.243$$

CHOSEN SIZE: L 75 x 50 x 7

8.2.4 Side transverses

The section modulus of side transverses supporting side longitudinals is not to be less than [cm³]

$$W1_{t_side}(S, l, p) := 0.55 \cdot S \cdot l^2 \cdot p \cdot k$$

Minimum cross sectional area of the web [cm²]:

$$A1_{t_side}(S, l, p) := 0.55 \cdot S \cdot l \cdot p \cdot k$$

in tanks acc. to 11.2.3:

$$W2_{t_side}(S, l, p) := 0.44 \cdot S \cdot l^2 \cdot p_2 \cdot k$$

$$A2_{t_side}(S, l, p) := 0.04 \cdot S \cdot l \cdot p_2 \cdot k$$

DODATAK A - Proračun u Mathcad programskom paketu

Final is bigger out of two:

$$W_{t_side}(S, l, p) := \max(W1_{t_side}(S, l, p), W2_{t_side}(S, l, p))$$

$$A_{t_side}(S, l, p) := \max(A1_{t_side}(S, l, p), A2_{t_side}(S, l, p))$$

$$l := 3 \quad p := 21.634 \quad S := 2.4$$

$$W_{t_side}(S, l, p) = 257.012$$

$$A_{t_side}(S, l, p) = 85.671 \quad \text{CHOSEN SIZE: HP160x8}$$

9 SUPPORTING DECK STRUCTURES

9.2 DECK BEAMS LONGITUDINALS AND GIRDERS

p - deck load p_D , p_{DA} or p_L , in [kN/m²]
(according to 3.2.1, 3.2.5 and 3.3.1.);

9.2.1 Transverse deck beams and deck longitudinals

Section modulus [cm³]:

$$W_d(f, s, p, l) := f \cdot s \cdot p \cdot l^2 \cdot k$$

$f = 0,55;$
 $f = 0,75$ for beams, girder and transverses
which are simply supported on one or
both ends;

$$m_2(l, s) := 0.204 \cdot \frac{s}{l} \cdot \left[4 - \left(\frac{s}{l} \right)^2 \right]$$

Shear area [cm²]:

$$A_d(l, s, p) := (1 - 0.817 \cdot m_2(l, s)) \cdot 0.05 \cdot s \cdot l \cdot p \cdot k$$

Accommodation Decks:

$$f := 0.55 \quad s := 0.6 \quad p := 8.489 \quad l := 3.6$$

$$W_d(f, s, p, l) = 36.306$$

$$A_d(l, s, p) = 0.816 \quad \text{cm}^2$$

Cargo Decks:

$$f := 0.55 \quad s := 0.6 \quad p := 44 \quad l := 3.6$$

$$W_d(f, s, p, l) = 188.179$$

$$A_d(l, s, p) = 4.228 \quad \text{cm}^2$$

9.2.4 Girders and transverses

Section modulus [cm³]:

$$W(f, b, p, l) := f \cdot b \cdot p \cdot l^2 \cdot k$$

Shear area [cm²]:

$$A_w(l, b, p) := 0.05 \cdot p \cdot b \cdot l \cdot k$$

DODATAK A - Proračun u Mathcad programskom paketu

Accommodation Decks:

$$\underline{f} := 0.55 \quad \underline{b} := 2.4 \quad \underline{p} := 8.489 \quad \underline{l} := 3.6$$

$$W(f, b, p, l) = 145.223$$

$$A_w(l, b, p) = 3.667 \text{ cm}^2$$

Cargo Decks:

$$\underline{f} := 0.55 \quad \underline{b} := 2.4 \quad \underline{p} := 44 \quad \underline{l} := 3.6$$

$$W(f, b, p, l) = 752.717$$

$$A_w(l, b, p) = 19.008 \text{ cm}^2$$

9.3 PILLARS

9.3.2 Scantlings

$$P_u(p, P_i, A) := p \cdot A + P_i$$

A - load area for one pillar, in [m²];

P_i - load from pillars located above the pillar considered, in [kN];

i_u = radius of gyration of the pillar:

$$i_u(A_u, I_u) := \sqrt{\frac{I_u}{A_u}}$$

λ_u = degree of slenderness of the pillar;

$$\lambda_u(I_u, I_u, A_u) := \frac{l_u}{i_u(A_u, I_u)}$$

I_u - moment of inertia of the pillar, in [cm⁴];

A_u - cross section area of selected pillar, in [cm²];

l_u - pillar length, in [cm];

For tubular pillars:

$$i_{ut}(d_{uv}, d_{uu}) := 0.25 \cdot \sqrt{d_{uv}^2 + d_{uu}^2}$$

DODATAK A - Proračun u Mathcad programskom paketu

Where σ_t , permissible compressive stress according to Table 9.3.2, in [N/mm²].

$$\sigma_t(l_u, loc, A_u, I_u) := \begin{cases} 140 - 0.0067 \cdot \lambda_u(l_u, I_u, A_u)^2 & \text{if } \lambda_u(l_u, I_u, A_u) \leq 100 \wedge loc = 1 \\ 117 - 0.0056 \cdot \lambda_u(l_u, I_u, A_u)^2 & \text{if } \lambda_u(l_u, I_u, A_u) \leq 100 \wedge loc \neq 1 \\ 7.3 \cdot \left(\frac{10^5}{\lambda_u(l_u, I_u, A_u)^2} \right) & \text{if } \lambda_u(l_u, I_u, A_u) > 100 \wedge loc = 1 \\ 6.1 \cdot \left(\frac{10^5}{\lambda_u(l_u, I_u, A_u)^2} \right) & \text{if } \lambda_u(l_u, I_u, A_u) > 100 \wedge loc \neq 1 \end{cases}$$

loc=1 for accommodation

loc≠1 for elsewhere

Sectional area of pillars is not to be less than [cm²]:

$$A_{u_min}(p, P_i, l_u, loc, A, A_u, I_u) := 10 \cdot \frac{P_u(p, P_i, A)}{\sigma_t(l_u, loc, A_u, I_u)}$$

$$P_i := 20 \quad p := 20 \quad l_u := 300 \quad i_{min} := 3.8 \quad A_u := 26.6 \quad I_u := 376 \quad loc := 1 \quad A := 10$$

$$A_{u_min}(p, P_i, l_u, loc, A, A_u, I_u) = 22.601$$

CHOSEN: ø139,7x8

DODATAK A - Proračun u Mathcad programskom paketu

11 TANK STRUCTURES

11.1.7 Minimum thickness

$$t_{\min} := 5.5 + 0.02 \cdot L = 7.02 \text{ mm}$$

11.2 SCANTLINGS

11.2.2 Plating

p = load p_1 or p_2 , in [kN/m²], according to Section 3.4 (the greater load to be taken);

$$t_1(p, t_k, s) := 1.1 \cdot s \cdot \sqrt{p \cdot k} + t_k$$

p_2 = load, in [kN/m²], according to 3.4;

$$t_2(p_2, t_k, s) := 0.9 \cdot s \cdot \sqrt{p_2 \cdot k} + t_k$$

$$\sigma_a(\tau_L, \sigma_L) := \sqrt{\left(\frac{235}{k}\right)^2 - 3 \cdot \tau_L^2 - 0.89 \cdot \sigma_L}$$

σ_L, τ_L = design hull girder bending or shear stress respectively, in [N/mm²], within the plate field considered as defined in Section 4.5.3;

$$t_{\text{tank}}(p, C, \tau_L, \sigma_L, t_k, s) := 16.8 \cdot C \cdot s \cdot \sqrt{\frac{p}{\sigma_a(\tau_L, \sigma_L)}} + t_k$$

$C = 1.0$, for transverse stiffening;

$C = 0.83$, for longitudinal stiffening.

Longitudinally non effective:

$$t(p_2, p, C, \tau_L, \sigma_L, t_k, \text{Effectivness}, s) := \begin{cases} \max(t_1(p, t_k, s), t_2(p_2, t_k, s), t_{\text{tank}}(p, C, \tau_L, \sigma_L, t_k, s), t_{\min}) & \text{if Effectivness} > 0 \\ \max(t_1(p, t_k, s), t_2(p_2, t_k, s), t_{\min}) & \text{if Effectivness} = 0 \end{cases}$$

FRESH WATER TANK

$$p := 29.45 \quad p_2 := 21.718 \quad s := 0.6 \quad C := 1 \quad \text{Effectivness} := 0 \quad \tau_L := 80 \quad \sigma_L := 100 \quad t_k := 1.5$$

$$t(p_2, p, C, \tau_L, \sigma_L, t_k, \text{Effectivness}, s) = 7.02 \quad \text{CHOSEN: 7.5 mm}$$

ROLL REDUCTION TANK

$$p := 20 \quad p_2 := 11.908 \quad s := 0.6 \quad C := 1 \quad \text{Effectivness} := 0 \quad \tau_L := 80 \quad \sigma_L := 100 \quad t_k := 1.5$$

$$t(p_2, p, C, \tau_L, \sigma_L, t_k, \text{Effectivness}, s) = 7.02 \quad \text{CHOSEN: 7 mm}$$

13 SUPERSTRUCTURES AND DECKHOUSES

13.1.1 Explanation

L_s = length of superstructure or deckhouse

B_s = breadth of superstructure or deckhouse

l_{start} = position of superstructure or deck house aft end from $x/L=0$

y_{center} = midbreadth position from C.L.

$$L_s := 19.4 \text{ m}$$

$$B_s := 15 \text{ m}$$

$$l_{start} := 28.7 \text{ m}$$

$$y_{center} := 0 \text{ m}$$



$$\text{type_of_structure} := \begin{cases} \text{"long deck house"} & \text{if } \left(\frac{l_{start}}{L} \geq 0.3 \wedge (L_s \geq 0.2 \cdot L \vee L_s \geq 12) \wedge \frac{B}{2} - \left[\left(\frac{B_s}{2} \right) - y_{center} \right] > 0.04 \cdot B \right. \\ \text{"effective superstructure"} & \text{if } \left(\frac{l_{start}}{L} \geq 0.3 \vee \left(\frac{l_{start} + L_s}{L} \right) \geq 0.3 \vee \left(\frac{l_{start}}{L} \right) \leq 0.7 \vee \left[\frac{l_{start} + L_s}{L} \right] \leq 0.7 \wedge L_s \geq 0.15 \cdot L \wedge \frac{B}{2} - \left[\left(\frac{B_s}{2} \right) - y_{center} \right] < 0.04 \cdot B \right. \\ \text{"non-effective superstructure"} & \text{if } \left(\frac{l_{start}}{L} \right) \leq 0.3 \vee \left[\frac{l_{start} + L_s}{L} \right] \leq 0.3 \vee \left(\frac{l_{start}}{L} \right) \geq 0.7 \wedge L_s \leq 0.15 \cdot L \wedge L_s \leq 12 \wedge \frac{B}{2} - \left[\left(\frac{B_s}{2} \right) - y_{center} \right] < 0.04 \cdot B \end{cases}$$

type_of_structure = "effective superstructure"

13.1.2 Definitions

Throughout this Section the following definitions apply:

k = material factor according to 1.4.2.2.

p_D = load according to 3.2.1.1.

p_s = load according to 3.2.2.1.

p_e = load according to 3.2.2.2.

p_{DA} = load according to 3.2.5.

p_L = load according to 3.3.1.1.

t_k = corrosion addition according to 2.9.1.

13.1.3 Strengthenings at the ends of superstructures

13.1.3.1 At the ends of superstructures one or both end bulkheads of which are located within $0,4 L$ amidships, the thickness of the shear strake, the strength deck in a breadth of $0,1 B$ from the shell, as well as the thickness of the superstructure side plating are to be strengthened as specified in Table 13.1.3.1. The strengthenings are to extend over a region from 4 frame spacings abaft the end bulkhead to 4 frame spacings forward of the end bulkheads.

Type of superstructure	Strengthening, in [%]	
	Strength deck and shear strake	Side plating of superstructure
Effective, according to 13.1.1.3	30	20
Non-effective	20	10

13.2 SIDE PLATING AND DECKS OF NON-EFFECTIVE SUPERSTRUCTURES

13.2.1 Side plating

$p = p_s$ or p_e as the case may be
 t_{min} = according to Section 5.2.6.

$p := 9.75 \text{ kN/m}^2$

$s_w := 0.6 \text{ m}$

$t_{min} := 8.718 \text{ mm}$

$t_k := 1.5 \text{ mm}$

$k := 1$

$t(s, p, k, t_k, t_{min}) := \max(1.21 \cdot s \cdot \sqrt{p \cdot k} + t_k, 0.8 \cdot t_{min}) \text{ mm}$

$p := 9.75 \text{ kN/m}^2$

$s_w := 0.6 \text{ m}$

$t_{min} := 8.718 \text{ mm}$

$t_k := 1.5 \text{ mm}$

$k := 1$

$t(s, p, k, t_k, t_{min}) = 6.974 \text{ mm}$

CHOSEN THICKNESS: 7 mm

13.2.1.2 The thickness of the side plating of upper tier superstructures may be reduced by 0,5 mm.

13.2.2 Deck plating

13.2.2.1 The thickness of deck plating is:

$p = p_{DA}$ or p_L , (the greater value is to be taken)
 L - need not be taken greater than 200 m.

$p := 4.15 \text{ kN/m}^2$

$s_w := 0.6 \text{ m}$

$k := 1$

$t_k := 1.5 \text{ mm}$

$t(s, p, k, t_k) := \max[1.21 \cdot s \cdot \sqrt{p \cdot k} + t_k, (5.5 + 0.02 \cdot \min(L, 200)) \cdot \sqrt{k}] \text{ mm}$

$p := 20 \text{ kN/m}^2$

$s_w := 0.6 \text{ m}$

$t_k := 1.5 \text{ mm}$

$k := 1$

$t(s, p, k, t_k) = 7.02 \text{ mm}$

CHOSEN THICKNESS: 7 mm

13.2.2.2 Where additional superstructure are arranged on non-effective superstructures located on the strength deck, the thickness required by 13.2.2.1 may be reduced by 10%.

13.2.3.1 The scantling of the deck beams and the supporting deck structure are to be determined in accordance with Section 9.2.

DODATAK A - Proračun u Mathcad programskom paketu

13.2.3.2 The scantlings of superstructure frames are given in Section 8.1.3.

13.3 SUPERSTRUCTURE END BULKHEADS AND DECKHOUSE WALLS

13.3.1 General

The following requirements apply to bulkheads forming the only protection for openings as per *Regulation 18 of LLC 1966* and for accommodations. These requirements define minimum scantlings based upon local lateral loads and it may be required that they be increased in individual cases.

These requirements do not apply to CSR Bulk Carriers.

13.3.2 Definitions

If calculating lowest tier of unprotected fronts -> structure = 1

If calculating 2-nd tier unprotected fronts -> structure = 2

If calculating 3-rd tier of sides and protected fronts -> structure = 3

If calculating aft ends abaft of admidship -> structure = 4

If calculating aft ends forward of admidship -> structure = 5

structure := 1

x = distance, in [m], between the bulkhead considered and aft end of the length L . When determining sides of a deckhouse, the deckhouse is to be subdivided into parts of approximately equal length, not exceeding $0,15 L$ each, and x is to be taken as the distance between aft end of the length L and the centre of each part considered.

z = vertical distance, in [m], from the summer load line to the midpoint of stiffener span, or to the middle of the plate field.

b' = breadth of deckhouse at the position considered, in [m];

B' = actual maximum breadth of ship on the exposed weather deck at the position considered, in [m].

$b' := 10$ m

$B' := 14$ m

$x := 30$ m

$z := 10$ m

$$n := \begin{cases} \left[20 + \left(\frac{\min(L, 300)}{12} \right) \right] & \text{if structure} = 1 \\ \left[10 + \left(\frac{\min(L, 300)}{12} \right) \right] & \text{if structure} = 2 \\ \left[5 + \left(\frac{\min(L, 300)}{15} \right) \right] & \text{if structure} = 3 \\ \left[7 + \left(\frac{\min(L, 300)}{100} \right) - 8 \cdot \left(\frac{x}{L} \right) \right] & \text{if structure} = 4 \\ \left[5 + \left(\frac{\min(L, 300)}{100} \right) - 4 \cdot \left(\frac{x}{L} \right) \right] & \text{if structure} = 5 \end{cases}$$

DODATAK A - Proračun u Mathcad programskom paketu

$$b := \begin{cases} 1 + \left[\frac{\left(\frac{x}{L}\right) - 0.45}{\begin{cases} \max(\min(C_b, 0.8), 0.6) & \text{if structure} \neq 5 \\ \max(C_b, 0.8) & \text{if structure} = 5 \end{cases}} \right]^2 & \text{if } \left(\frac{x}{L}\right) < 0.45 \\ 1 + 1.5 \cdot \left[\frac{\left(\frac{x}{L}\right) - 0.45}{\begin{cases} \max(\min(C_b, 0.8), 0.6) & \text{if structure} \neq 5 \\ \max(C_b, 0.8) & \text{if structure} = 5 \end{cases}} \right]^2 & \text{if } \left(\frac{x}{L}\right) \geq 0.45 \end{cases}$$

$$f := \begin{cases} 0.1 \cdot L \cdot e^{\left(\frac{-L}{300}\right)} - \left[1 - \left(\frac{L}{150}\right)^2 \right] & \text{if } L < 150 \\ 0.1 \cdot L \cdot e^{\left(\frac{-L}{300}\right)} & \text{if } 150 \leq L \leq 300 \\ 11 & \text{if } L > 300 \end{cases}$$

If calculating structure of exposed parts of machinery casing -> mach_casing = 1
otherwise mach_casing = 0

mach_casing := 0

$$c_m := \begin{cases} \left[0.3 + 0.7 \cdot \max\left[\left(\frac{b'}{B'}\right), 0.25\right] \right] & \text{if mach_casing} = 0 \\ 1 & \text{if mach_casing} = 1 \end{cases}$$

$$p_A := \max\left[n \cdot c \cdot (b \cdot f - z), \begin{cases} 30 & \text{if structure} = 1 \wedge L \leq 50 \\ \left[25 + \left(\frac{L}{50}\right) \right] & \text{if structure} = 1 \wedge 50 < L \leq 250 \\ 50 & \text{if structure} = 1 \wedge L > 250 \\ 15 & \text{if structure} = 0 \wedge L \leq 50 \\ \left[12.5 + \left(\frac{L}{20}\right) \right] & \text{if structure} = 0 \wedge 50 < L \leq 250 \\ 25 & \text{if structure} = 0 \wedge L > 250 \end{cases} \right]$$

$$p_A = 26.52 \quad \text{kN/m}^2$$

13.3.3 Scantlings

13.3.3.1 Stiffeners

The section modulus of the stiffeners is to be determined according to the following formula:

l = unsupported span, in [m]; l is to be taken as the superstructure height or deckhouse height respectively, however,
not less than 2,0 m;

s = spacing of stiffeners, in [m].

$$s := 0.6 \quad \text{m}$$

$$l := 2.7 \quad \text{m}$$

$$k := 1$$

DODATAK A - Proračun u Mathcad programskom paketu

$$W(s, l, k, p_A) := 0.35 \cdot s \cdot (\max(1, 2))^2 \cdot p_A \cdot k \quad \text{cm}^3$$

$$l := 2.7 \quad \text{m} \quad s := 0.6 \quad \text{m} \quad k := 1$$

$$W(s, l, k, p_A) = 40.599 \quad \text{mm} \quad \text{CHOSEN STIFFENERS: L75x50x7 mm}$$

13.3.3.2 Plate thickness

The thickness of the plating is to be determined according to the following formula:

$$t := \max \left[0.95 \cdot s \cdot \sqrt{p_A \cdot k} + t_k, \begin{cases} \left(5 + \frac{L}{100} \right) \cdot \sqrt{k} & \text{if structure} = 1 \\ \left(4 + \frac{L}{100} \right) \cdot \sqrt{k} & \text{if structure} \neq 1 \end{cases} \right]$$

$$t = 5.76 \quad \text{mm} \quad \text{CHOSEN THICKNESS: 7 mm}$$

When determining p_A , z is to be measured to the middle of the plate field.

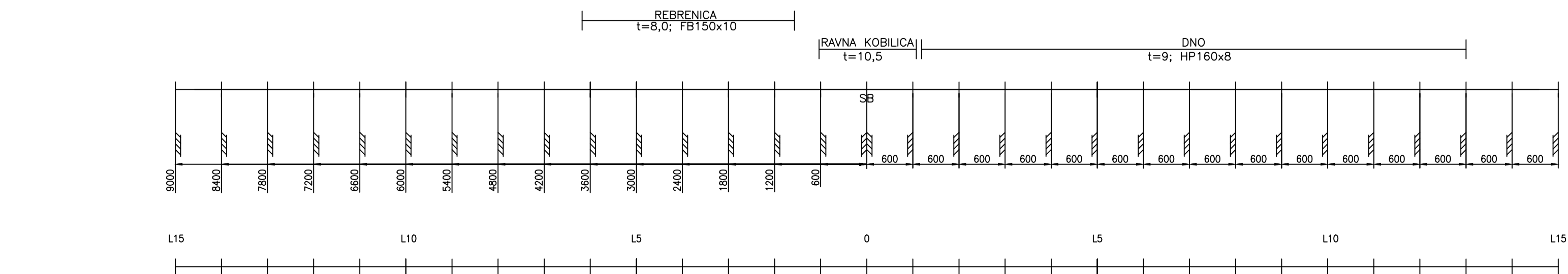
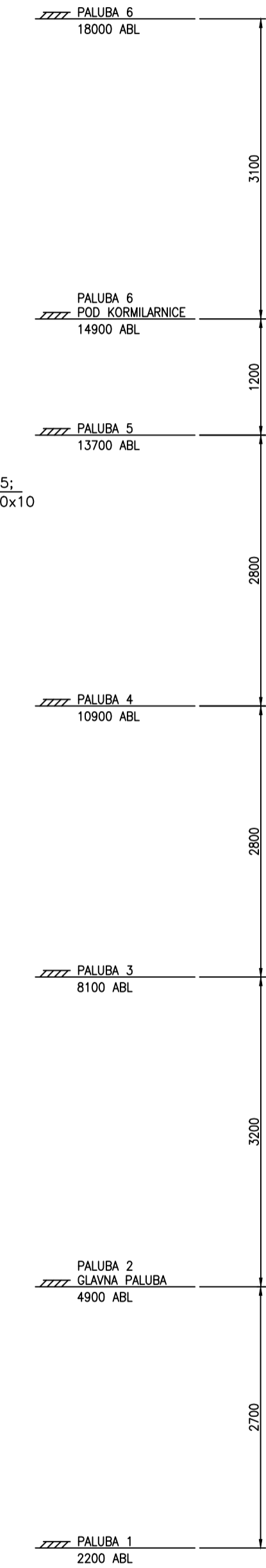
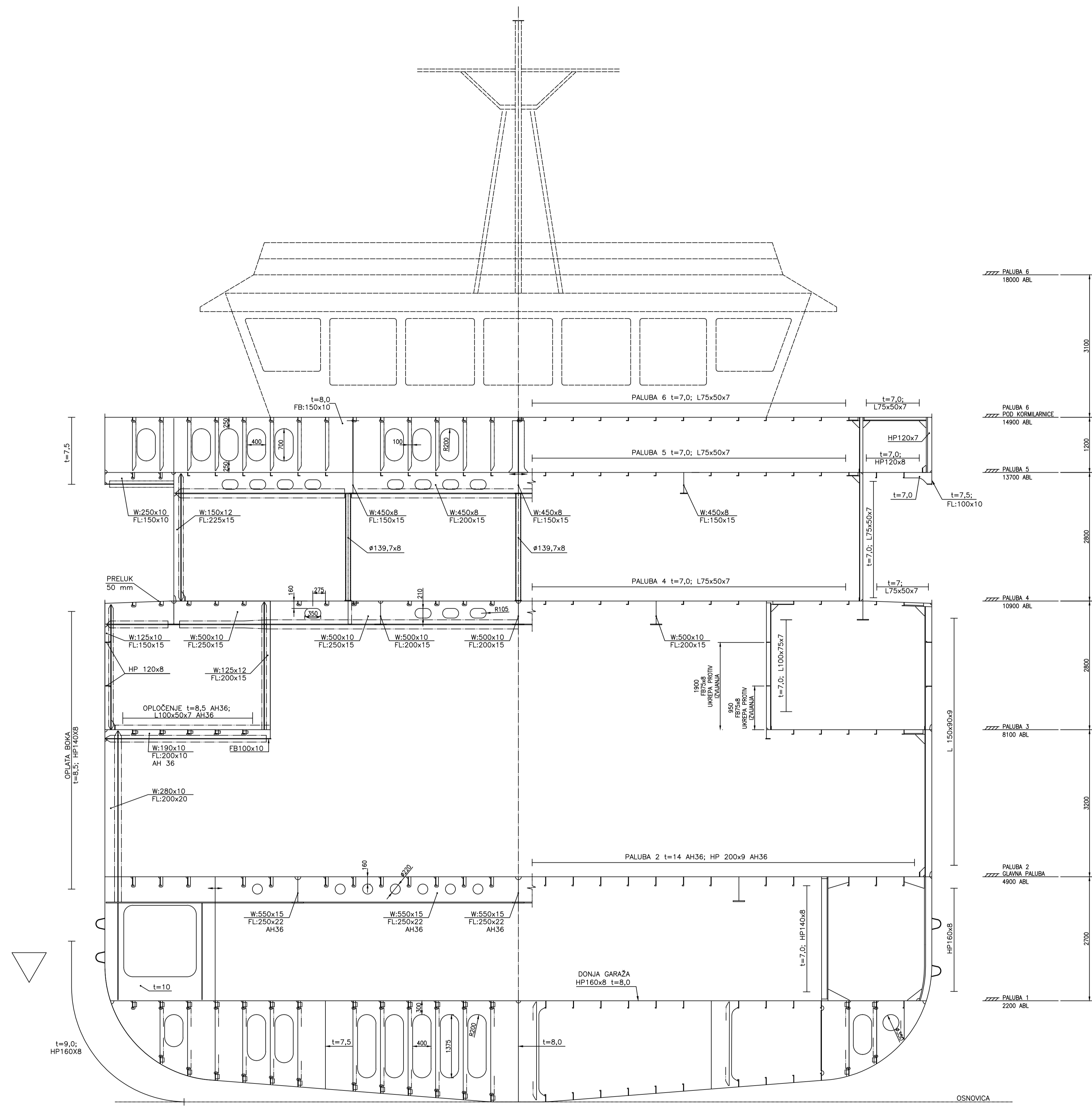

GLAVNE ZNAČAJKE

DULJINA PREKO SVEGA	79,50 m
DULJINA NA GLAVNOJ PALUBI	79,20 m
ŠIRINA	18,00 m
VISINA	4,60 m
GAZ	2,50 m
KONSTRUKTIVNI (MAX) GAZ	2,70 m
RAZMAK OKVIRNIH REBARA	SVAKO 4. REBRO

NAPOMENE

MATERIJAL: CRS-A AKO NIJE NAVEDENO DRUGAČIJE
 NOSIVOST GLAVNE PALUBE: OSOVINSKO OPTEREĆENJE 12 TONA, DVOSTRUKI KOTAČI
 NOSIVOST POKROVA DVODNA: OSOVINSKO OPTEREĆENJE 2 TONE, JEDNOSTRUKI KOTAČI

Mjerilo: 1:50	Zadatak za diplomski rad: Projekt strukture trupa dvostranog trajekta duljine 80 m za Jadran	Sveučilište u Rijeci TEHNIČKI FAKULTET Diplomski sveučilišni studij brodogradnje
Format: A1		
Crtao: Maša Stanković 0069074798	Naslov: DODATAK B GLAVNO REBRO	
Predmet: Čvrstota broda	Datum: 20.09.2022	Stranica: 1/1
		Revizija: 00

DODATAK C

Proračun i provjera strukturnih elemenata primjenom DNV 3D-Beam programskog alata

Rešetkasta primarna struktura glavne palube

Beam information, sorted by Beam in Ascending order

Beam	Beam Name	Start Node	End Node	Elastic Length [mm]	Mass [kg]	Profile	Angle [deg]	Rigid Start [mm]	Rigid End [mm]	Hinged at Start	Hinged at End	Non Linearities
1		1	3	1800	583	2	180,0	0	0			
2		3	5	4800	1555	2	180,0	0	0			
3		4	2	1800	583	2	180,0	0	0			
4		5	4	4800	1555	2	180,0	0	0			
5		6	7	4800	1555	2	180,0	0	0			
6		8	6	4800	1555	2	180,0	0	0			
7		7	9	1800	583	2	180,0	0	0			
8		10	8	1800	583	2	180,0	0	0			
9		11	12	4800	1555	2	180,0	0	0			
10		13	11	4800	1555	2	180,0	0	0			
11		12	14	1800	583	2	180,0	0	0			
12		15	13	1800	583	2	180,0	0	0			
13		16	17	4800	1555	2	180,0	0	0			
14		18	16	4800	1555	2	180,0	0	0			
15		17	19	1800	583	2	180,0	0	0			
16		20	18	1800	583	2	180,0	0	0			
17		21	22	4800	1555	2	180,0	0	0			
18		23	21	4800	1555	2	180,0	0	0			
19		22	24	1800	583	2	180,0	0	0			
20		25	23	1800	583	2	180,0	0	0			
21		5	6	2400	778	1	180,0	0	0			
22		6	11	2400	778	1	180,0	0	0			
23		11	16	2400	778	1	180,0	0	0			
24		16	21	2400	778	1	180,0	0	0			
25		18	23	2400	778	1	180,0	0	0			
26		13	18	2400	778	1	180,0	0	0			
27		8	13	2400	778	1	180,0	0	0			
28		3	8	2400	778	1	180,0	0	0			
29		17	22	2400	778	1	180,0	0	0			
30		12	17	2400	778	1	180,0	0	0			
31		7	12	2400	778	1	180,0	0	0			
32		4	7	2400	778	1	180,0	0	0			
33		4	26	2400	778	1	180,0	0	0			
34		26	27	2400	778	1	180,0	0	0			
35		27	28	2400	778	1	180,0	0	0			
36		28	29	2400	778	1	180,0	0	0			
37		3	30	2400	778	1	180,0	0	0			
38		30	31	2400	778	1	180,0	0	0			
39		31	32	2400	778	1	180,0	0	0			
40		32	33	2400	778	1	180,0	0	0			
41		34	35	2400	778	1	180,0	0	0			
42		36	34	2400	778	1	180,0	0	0			
43		37	36	2400	778	1	180,0	0	0			
44		5	37	2400	778	1	180,0	0	0			
45		38	33	1800	583	2	180,0	0	0			
46		29	39	1800	583	2	180,0	0	0			
47		33	35	4800	1555	2	180,0	0	0			
48		35	29	4800	1555	2	180,0	0	0			
49		40	32	1800	583	2	180,0	0	0			
50		28	41	1800	583	2	180,0	0	0			
51		32	34	4800	1555	2	180,0	0	0			
52		34	28	4800	1555	2	180,0	0	0			
53		42	31	1800	583	2	180,0	0	0			

DODATAK C

Proračun i provjera strukturnih elemenata primjenom DNV 3D-Beam programskog alata

Rešetkasta primarna struktura glavne palube

Beam information, sorted by Beam in Ascending order

Beam	Beam Name	Start Node	End Node	Elastic Length [mm]	Mass [kg]	Profile	Angle [deg]	Rigid Start [mm]	Rigid End [mm]	Hinged at Start	Hinged at End	Non Linearities
54		27	43	1800	583	2	180,0	0	0			
55		31	36	4800	1555	2	180,0	0	0			
56		36	27	4800	1555	2	180,0	0	0			
57		44	30	1800	583	2	180,0	0	0			
58		26	45	1800	583	2	180,0	0	0			
59		30	37	4800	1555	2	180,0	0	0			
60		37	26	4800	1555	2	180,0	0	0			

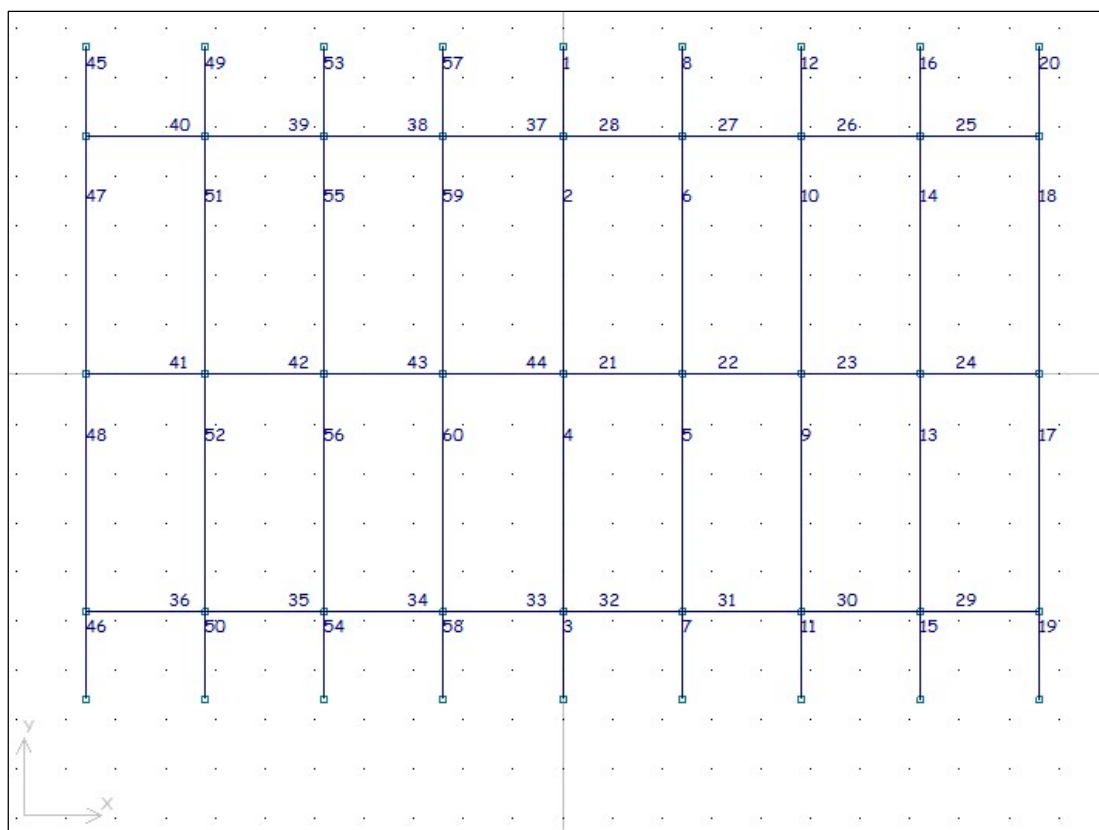

Abbreviations

Beam information:

Beam: Beam identification number

Beam Name: User's beam identification

Start/End Node: Node numbers for the start and end nodes respectively

Elastic length: Elastic length of beam, excluding possible rigid ends

Mass: Mass of the elastic length of beam

Profile: Profile identification number

Angle: Angle between the profile's z-axis and the plane through the beam and the global Z-axis. Positive for clockwise rotation when seen in positive local x-direction.

Rigid Start/End: Length of possible rigid part of the beam at the start and end ends respectively

Hinged at Start/End: Possibly defined hinge at the start and end nodes respectively, where hinges are defined as:

dX, dY, dZ: Hinged with respect to translation in the global X-, Y-, and Z-direction respectively

rX, rY, rZ: Hinged with respect to rotation about the global X-, Y-, and Z-axis respectively

DODATAK C

Proračun i provjera strukturnih elemenata primjenom DNV 3D-Beam programskog alata

Rešetkasta primarna struktura glavne palube

Non Linearities: Possibly specified non-linear properties for the beam. For definition see figure below.

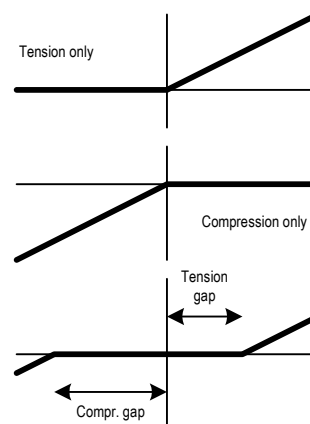

DODATAK C

Proračun i provjera strukturnih elemenata primjenom DNV 3D-Beam programskog alata

Rešetkasta primarna struktura glavne palube

Node information, sorted by Node in Ascending order

Node No	Name	X [mm]	Y [mm]	Z [mm]	Boundary Conditions					
					X transl	Y transl	Z transl	X rot	Y rot	Z rot
1		0	6600	0	Fixed	Fixed	Fixed	Fixed	Fixed	Fixed
2		0	-6600	0	Fixed	Fixed	Fixed	Fixed	Fixed	Fixed
3		0	4800	0						
4		0	-4800	0						
5		0	0	0						
6		2400	0	0						
7		2400	-4800	0						
8		2400	4800	0						
9		2400	-6600	0	Fixed	Fixed	Fixed	Fixed	Fixed	Fixed
10		2400	6600	0	Fixed	Fixed	Fixed	Fixed	Fixed	Fixed
11		4800	0	0						
12		4800	-4800	0						
13		4800	4800	0						
14		4800	-6600	0	Fixed	Fixed	Fixed	Fixed	Fixed	Fixed
15		4800	6600	0	Fixed	Fixed	Fixed	Fixed	Fixed	Fixed
16		7200	0	0						
17		7200	-4800	0						
18		7200	4800	0						
19		7200	-6600	0	Fixed	Fixed	Fixed	Fixed	Fixed	Fixed
20		7200	6600	0	Fixed	Fixed	Fixed	Fixed	Fixed	Fixed
21		9600	0	0						
22		9600	-4800	0						
23		9600	4800	0						
24		9600	-6600	0	Fixed	Fixed	Fixed	Fixed	Fixed	Fixed
25		9600	6600	0	Fixed	Fixed	Fixed	Fixed	Fixed	Fixed
26		-2400	-4800	0						

DODATAK C

Proračun i provjera strukturnih elemenata primjenom DNV 3D-Beam programskog alata

Rešetkasta primarna struktura glavne palube

Node information, sorted by Node in Ascending order

Node No	Name	X [mm]	Y [mm]	Z [mm]	Boundary Conditions					
					X transl	Y transl	Z transl	X rot	Y rot	Z rot
27		-4800	-4800	0						
28		-7200	-4800	0						
29		-9600	-4800	0						
30		-2400	4800	0						
31		-4800	4800	0						
32		-7200	4800	0						
33		-9600	4800	0						
34		-7200	0	0						
35		-9600	0	0						
36		-4800	0	0						
37		-2400	0	0						
38		-9600	6600	0	Fixed	Fixed	Fixed	Fixed	Fixed	Fixed
39		-9600	-6600	0	Fixed	Fixed	Fixed	Fixed	Fixed	Fixed
40		-7200	6600	0	Fixed	Fixed	Fixed	Fixed	Fixed	Fixed
41		-7200	-6600	0	Fixed	Fixed	Fixed	Fixed	Fixed	Fixed
42		-4800	6600	0	Fixed	Fixed	Fixed	Fixed	Fixed	Fixed
43		-4800	-6600	0	Fixed	Fixed	Fixed	Fixed	Fixed	Fixed
44		-2400	6600	0	Fixed	Fixed	Fixed	Fixed	Fixed	Fixed
45		-2400	-6600	0	Fixed	Fixed	Fixed	Fixed	Fixed	Fixed

DODATAK C

Proračun i provjera strukturnih elemenata primjenom DNV 3D-Beam programskog alata

Rešetkasta primarna struktura glavne palube

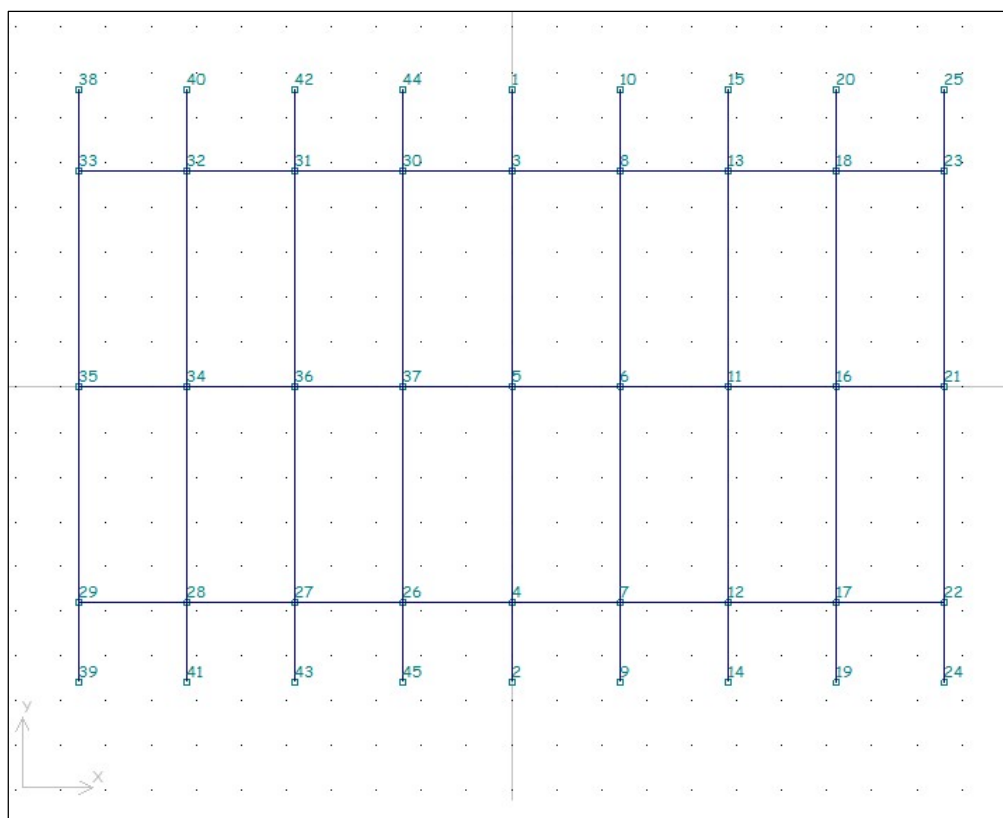

Abbreviations

Node No:	Node identification number
Name:	User's node identification
X, Y, Z:	Node coordinates in the global coordinate system
X transl, Y transl, Z transl:	Boundary conditions w.r.t. translation along the global axes
X rot, Y rot, Zrot:	Boundary conditions w.r.t. rotation about the global axes

Where:

Free:	The node is free
Fixed:	The node is fixed
FD:	The node has a prescribed displacement or rotation
Spring:	The node is supported by a spring

DODATAK C

Proračun i provjera strukturnih elemenata primjenom DNV 3D-Beam programskog alata

Rešetkasta primarna struktura glavne palube

Profiles used in the model

Profiles

Profile	Profile Name	Type	Material	Ignore S. C.	Shear factor fy	Shear factor fz	Profile parameters
1	Palubna proveza	40	3 VL-36 Steel		1,00	1,00	Effective plate Width=2088 [mm], Plate Thickness, pT=14 [mm], Web Height, hw=550 [mm], Web Thickness, t=15 [mm], Flange width (incl. web), bf=250 [mm], Flange thickness, tf=22 [mm], Angle Between Profile & Plate=90 [Degrees], Neglectlyz=True
2	Okvirne sponje	40	3 VL-36 Steel		1,00	1,00	Effective plate Width=2088 [mm], Plate Thickness, pT=14 [mm], Web Height, hw=550 [mm], Web Thickness, t=15 [mm], Flange width (incl. web), bf=250 [mm], Flange thickness, tf=22 [mm], Angle Between Profile & Plate=90 [Degrees], Neglectlyz=True

Profile properties

Profile	Axial			Local x-z plane				Local x-y plane				Shear Centre	
	Ax [mm ²]	Wx [mm ³]	Ix [mm ⁴]	Az [mm ²]	Wy _t [mm ³]	Wy _b [mm ³]	Iy [mm ⁴]	Ay [mm ²]	Wz ₊ [mm ³]	Wz ₋ [mm ³]	Iz [mm ⁴]	ey [mm]	ez [mm]
1	41535	205029	2,9729e+06	7427	4193010	14086481	1,8919e+09	35304	9836212	9836212	1,0269e+10	0	-125,8
2	41535	205029	2,9729e+06	7427	4193010	14086481	1,8919e+09	35304	9836212	9836212	1,0269e+10	0	-125,8

Materials

Material	Material Name	E [N/mm ²]	Density [kg/m ³]	Poisson	Thermal Coefficient [mm/mm/C]	Yield Stress [N/mm ²]	Ultimate Strength [N/mm ²]
3	VL-36 Steel	210000	7800,0	0,30	1,26e-05	355	490

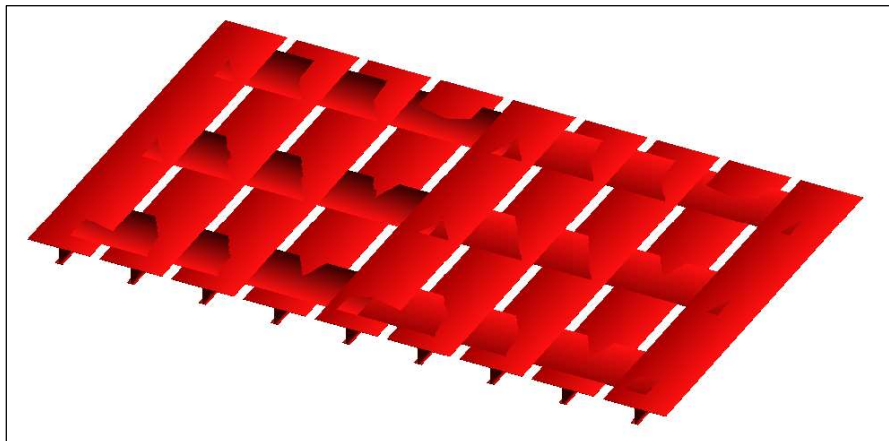

Abbreviations

Profiles:

Profile: Profile identification number

Profile Name: User's profile identification

Type: Profile type

Material: Material identification

Ignore S.C.: If ticked "X", then the program ignores the possible shear centre offset for the profile.

Shear factors fy, fz: The shear factor may be < 1.0 for beams with large cut-outs. The factors affect the beam stiffness but not the computed shear stress.

Profile parameters: Input parameters defining the profile.

DODATAK C

Proračun i provjera strukturnih elemenata primjenom DNV 3D-Beam programskog alata

Rešetkasta primarna struktura glavne palube

Profile properties:

Profile:	Profile identification number
Ax:	Axial area (total profile area)
Wx:	Torsion section modulus
Ix:	Torsional moment of inertia
Az:	Shear area in local z-direction ($I_y t_p / S_y$)
W _{y_t} :	Section modulus about local y-axis at top of profile
W _{y_b} :	Section modulus about local y-axis at bottom of profile
I _y :	Moment of inertia about local y-axis
A _y :	Shear area in local y-direction ($I_z t_p / S_z$)
W _{z₊} :	Section modulus about local z-axis on positive y-side of profile
W _{z₋} :	Section modulus about local z-axis on negative y-side of profile
I _z :	Moment of inertia about local z-axis
	Note: $W_{z_t} = W_{z_b} = W_{z_{min}}$ for all profile types except I - types
e _y :	Shear centre distance from vertical neutral axis
e _z :	Shear centre distance from horizontal neutral axis
f _y :	Shear factor in local y-direction
f _z :	Shear factor in local z-direction
	Note: The shear factor is used for shear stiffness of beam, but not for calculation of shear stress
Where:	
S _y , S _z :	1 st area moment about y- and z- axis respectively
t _p :	value for profile thickness depending on profile type

Materials:

Material:	Material identification
Material Name:	User's material identification
E:	Young's Modulus
Density:	Density
Poisson:	Poisson's ratio for transverse contraction
Thermal Coefficient:	Coefficient of thermal expansion
Yield Stress:	Nominal yield stress
Ultimate Strength:	Nominal ultimate tensile strength

DODATAK C

Proračun i provjera strukturnih elemenata primjenom DNV 3D-Beam programskog alata

Rešetkasta primarna struktura glavne palube

Beam Loads in local coordinate system, sorted by Beam in Ascending order

Beam No	Distributed Loads						Temperature Loads		
	Px1 [N/mm]	Py1 [N/mm]	Pz1 [N/mm]	Px2 [N/mm]	Py2 [N/mm]	Pz2 [N/mm]	Gy [C/mm]	Gz [C/mm]	Temperature [C]
1	0	0	32,5	0	0	32,5			
2	0	0	57,2	0	0	62,4			
3	0	0	32,5	0	0	32,5			
4	0	0	57,2	0	0	62,4			
5	0	0	57,2	0	0	62,4			
6	0	0	57,2	0	0	62,4			
7	0	0	32,5	0	0	32,5			
8	0	0	32,5	0	0	32,5			
9	0	0	57,2	0	0	62,4			
10	0	0	57,2	0	0	62,4			
11	0	0	32,5	0	0	32,5			
12	0	0	32,5	0	0	32,5			
13	0	0	57,2	0	0	62,4			
14	0	0	57,2	0	0	62,4			
15	0	0	32,5	0	0	32,5			
16	0	0	32,5	0	0	32,5			
17	0	0	57,2	0	0	62,4			
18	0	0	57,2	0	0	62,4			
19	0	0	32,5	0	0	32,5			
20	0	0	32,5	0	0	32,5			
45	0	0	32,5	0	0	32,5			
46	0	0	32,5	0	0	32,5			
47	0	0	57,2	0	0	62,4			
48	0	0	57,2	0	0	62,4			
49	0	0	32,5	0	0	32,5			
50	0	0	32,5	0	0	32,5			
51	0	0	57,2	0	0	62,4			
52	0	0	57,2	0	0	62,4			
53	0	0	32,5	0	0	32,5			
54	0	0	32,5	0	0	32,5			
55	0	0	57,2	0	0	62,4			
56	0	0	57,2	0	0	62,4			
57	0	0	32,5	0	0	32,5			
58	0	0	32,5	0	0	32,5			
59	0	0	57,2	0	0	62,4			
60	0	0	57,2	0	0	62,4			

Abbreviations

Beam No: Beam identification number
 Px1, Px2: Load intensity in local x-direction at the start and end ends of the beam respectively
 Py1, Py2: Load intensity in local y-direction at the start and end ends of the beam respectively
 Pz1, Pz2: Load intensity in local z-direction at the start and end ends of the beam respectively
 Gy, Gz: Temperature gradients in local y- and z-directions
 Temperature: Mean temperature. NB! Any non-zero value is regarded as a temperature load

DODATAK C

Proračun i provjera strukturnih elemenata primjenom DNV 3D-Beam programskog alata

Rešetkasta primarna struktura glavne palube

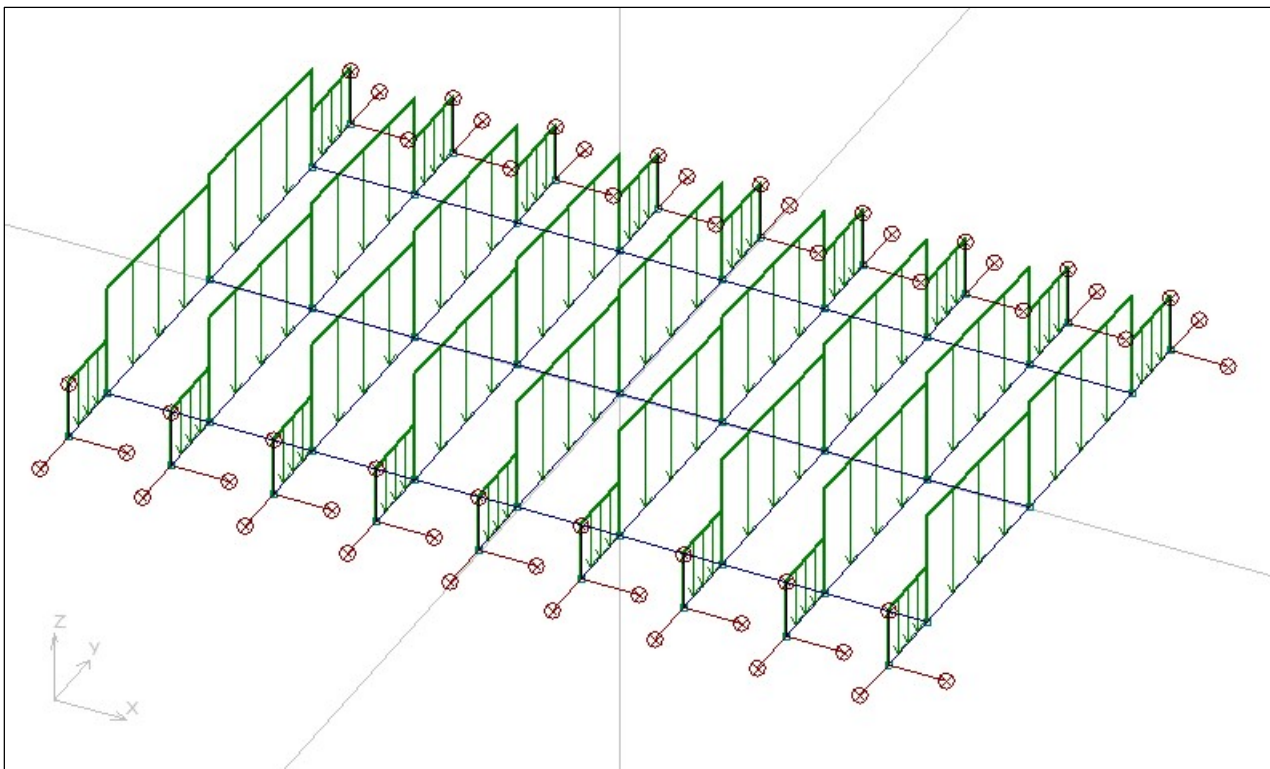

DODATAK C

Proračun i provjera strukturnih elemenata primjenom DNV 3D-Beam programskog alata

Rešetkasta primarna struktura glavne palube

Beam Stresses, values, sorted by Sig-My in Descending order

Beam No.	σ_{Nx} [N/mm ²]	τ_{Qy} [N/mm ²]	τ_{Qz} [N/mm ²]	τ_{Mx} [N/mm ²]	σ_{My} [N/mm ²]	σ_{Mz} [N/mm ²]
3	0	0	47	0	198	0
7	0	0	47	0	198	0
11	0	0	47	0	198	0
15	0	0	47	0	198	0
19	0	0	47	0	198	0
46	0	0	47	0	198	0
50	0	0	47	0	198	0
54	0	0	47	0	198	0
58	0	0	47	0	198	0
1	0	0	46	0	197	0
8	0	0	46	0	197	0
12	0	0	46	0	197	0
16	0	0	46	0	197	0
20	0	0	46	0	197	0
45	0	0	46	0	197	0
49	0	0	46	0	197	0
53	0	0	46	0	197	0
57	0	0	46	0	197	0
2	0	0	38	0	103	0
6	0	0	38	0	103	0
10	0	0	38	0	103	0
14	0	0	38	0	103	0
18	0	0	38	0	103	0
47	0	0	38	0	103	0
51	0	0	38	0	103	0
55	0	0	38	0	103	0
59	0	0	38	0	103	0
4	0	0	39	0	103	0
5	0	0	39	0	103	0
9	0	0	39	0	103	0
13	0	0	39	0	103	0
17	0	0	39	0	103	0
48	0	0	39	0	103	0
52	0	0	39	0	103	0
56	0	0	39	0	103	0
60	0	0	39	0	103	0
21	0	0	0	0	0	0
22	0	0	0	0	0	0
23	0	0	0	0	0	0
24	0	0	0	0	0	0
25	0	0	0	0	0	0
26	0	0	0	0	0	0
27	0	0	0	0	0	0
28	0	0	0	0	0	0
29	0	0	0	0	0	0
30	0	0	0	0	0	0
31	0	0	0	0	0	0
32	0	0	0	0	0	0
33	0	0	0	0	0	0
34	0	0	0	0	0	0
35	0	0	0	0	0	0
36	0	0	0	0	0	0
37	0	0	0	0	0	0

DODATAK C

Proračun i provjera strukturnih elemenata primjenom DNV 3D-Beam programskog alata

Rešetkasta primarna struktura glavne palube

Beam Stresses, values, sorted by Sig-My in Descending order

Beam No.	σ_{Nx} [N/mm ²]	τ_{Qy} [N/mm ²]	τ_{Qz} [N/mm ²]	τ_{Mx} [N/mm ²]	σ_{My} [N/mm ²]	σ_{Mz} [N/mm ²]
38	0	0	0	0	0	0
39	0	0	0	0	0	0
40	0	0	0	0	0	0
41	0	0	0	0	0	0
42	0	0	0	0	0	0
43	0	0	0	0	0	0
44	0	0	0	0	0	0

Combined Element stresses

Beam No.	σ_{Ny} (min) [N/mm ²]	σ_{Ny} (max) [N/mm ²]	σ_{Nz} (min) [N/mm ²]	σ_{Nz} (max) [N/mm ²]
3	198	59	0	0
7	198	59	0	0
11	198	59	0	0
15	198	59	0	0
19	198	59	0	0
46	198	59	0	0
50	198	59	0	0
54	198	59	0	0
58	198	59	0	0
1	197	59	0	0
8	197	59	0	0
12	197	59	0	0
16	197	59	0	0
20	197	59	0	0
45	197	59	0	0
49	197	59	0	0
53	197	59	0	0
57	197	59	0	0
2	62	103	0	0
6	62	103	0	0
10	62	103	0	0
14	62	103	0	0
18	62	103	0	0
47	62	103	0	0
51	62	103	0	0
55	62	103	0	0
59	62	103	0	0
4	61	103	0	0
5	61	103	0	0
9	61	103	0	0
13	61	103	0	0
17	61	103	0	0
48	61	103	0	0
52	61	103	0	0
56	61	103	0	0
60	61	103	0	0
21	0	0	0	0
22	0	0	0	0
23	0	0	0	0
24	0	0	0	0
25	0	0	0	0
26	0	0	0	0

DODATAK C

Proračun i provjera strukturnih elemenata primjenom DNV 3D-Beam programskog alata Rešetkasta primarna struktura glavne palube

Combined Element stresses

Beam No.	σ_{Ny} (min) [N/mm ²]	σ_{Ny} (max) [N/mm ²]	σ_{Nz} (min) [N/mm ²]	σ_{Nz} (max) [N/mm ²]
27	0	0	0	0
28	0	0	0	0
29	0	0	0	0
30	0	0	0	0
31	0	0	0	0
32	0	0	0	0
33	0	0	0	0
34	0	0	0	0
35	0	0	0	0
36	0	0	0	0
37	0	0	0	0
38	0	0	0	0
39	0	0	0	0
40	0	0	0	0
41	0	0	0	0
42	0	0	0	0
43	0	0	0	0
44	0	0	0	0

Abbreviations

Principal stresses:

- σ_{Nx} : Axial stress (N_x/A_x)
- τ_{Mx} : Torsional stress (M_x/W_x)
- τ_{Qy} : Shear stress in local y-direction (Q_y/A_y)
- τ_{Qz} : Shear stress in local z-direction (Q_z/A_z)
- σ_{My} : Bending stress about local y-axis (M_y/W_y)
- σ_{Mz} : Bending stress about local z-axis (M_z/W_z)

Stress combinations:

- $\sigma_{Ny}(\text{min})$: Normal stress in local xz-plane, max of ($\sigma_{Nx} + \sigma_{My}(\text{min})$)
- $\sigma_{Ny}(\text{max})$: Normal stress in local xz-plane, max of ($\sigma_{Nx} + \sigma_{My}(\text{max})$)
- $\sigma_{Nz}(\text{min})$: Normal stress in local xy-plane, max of ($\sigma_{Nx} + \sigma_{Mz}(\text{min})$)
- $\sigma_{Nz}(\text{max})$: Normal stress in local xy-plane, max of ($\sigma_{Nx} + \sigma_{Mz}(\text{max})$)

Where:

- A_x : Axial area (total profile area)
- A_y : Shear area in local y-direction ($I_z t_p / S_z$)
- A_z : Shear area in local z-direction ($I_y t_p / S_y$)
- W_x : Torsion section modulus
- W_y : Minimum section modulus about local y-axis
- W_z : Minimum section modulus about local z-axis
- N_x : Axial force
- Q_y : Shear force in local y-direction
- Q_z : Shear force in local z-direction
- M_x : Torsional moment
- M_y : Bending moment about local y-axis
- M_z : Bending moment about local z-axis
- S_y, S_z : 1st area moment about y- and z- axis respectively
- t_p : profile thickness value depending on profile type

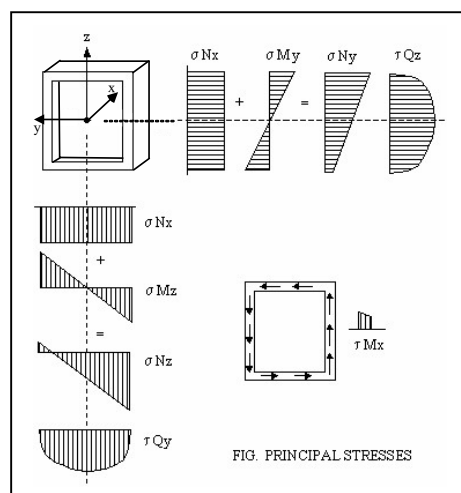

DODATAK C

Proračun i provjera strukturnih elemenata primjenom DNV 3D-Beam programskog alata

Rešetkasta primarna struktura glavne palube

Effective Stress, values, sorted by SigEff in Descending order

Beam No.	σ_{eff} [N/mm ²]	Usage	x-pos [mm]	y-pos [mm]	z-pos [mm]	σ_{N_x} [N/mm ²]	σ_{M_y} [N/mm ²]	σ_{M_z} [N/mm ²]	τ_{M_x} [N/mm ²]	τ_{Q_y} [N/mm ²]	τ_{Q_z} [N/mm ²]
3	200	0,56	1800	0	440,2	0	193	0	0	0	29
7	200	0,56	1800	0	440,2	0	193	0	0	0	29
11	200	0,56	1800	0	440,2	0	193	0	0	0	29
15	200	0,56	1800	0	440,2	0	193	0	0	0	29
19	200	0,56	1800	0	440,2	0	193	0	0	0	29
46	200	0,56	1800	0	440,2	0	193	0	0	0	29
50	200	0,56	1800	0	440,2	0	193	0	0	0	29
54	200	0,56	1800	0	440,2	0	193	0	0	0	29
58	200	0,56	1800	0	440,2	0	193	0	0	0	29
1	198	0,56	0	0	440,2	0	192	0	0	0	28
8	198	0,56	0	0	440,2	0	192	0	0	0	28
12	198	0,56	0	0	440,2	0	192	0	0	0	28
16	198	0,56	0	0	440,2	0	192	0	0	0	28
20	198	0,56	0	0	440,2	0	192	0	0	0	28
45	198	0,56	0	0	440,2	0	192	0	0	0	28
49	198	0,56	0	0	440,2	0	192	0	0	0	28
53	198	0,56	0	0	440,2	0	192	0	0	0	28
57	198	0,56	0	0	440,2	0	192	0	0	0	28
2	103	0,29	4800	125	451,2	0	103	0	0	0	0
4	103	0,29	0	125	451,2	0	103	0	0	0	0
5	103	0,29	0	125	451,2	0	103	0	0	0	0
6	103	0,29	4800	125	451,2	0	103	0	0	0	0
9	103	0,29	0	125	451,2	0	103	0	0	0	0
10	103	0,29	4800	125	451,2	0	103	0	0	0	0
13	103	0,29	0	125	451,2	0	103	0	0	0	0
14	103	0,29	4800	125	451,2	0	103	0	0	0	0
17	103	0,29	0	125	451,2	0	103	0	0	0	0
18	103	0,29	4800	125	451,2	0	103	0	0	0	0
47	103	0,29	4800	125	451,2	0	103	0	0	0	0
48	103	0,29	0	125	451,2	0	103	0	0	0	0
51	103	0,29	4800	125	451,2	0	103	0	0	0	0
52	103	0,29	0	125	451,2	0	103	0	0	0	0
55	103	0,29	4800	125	451,2	0	103	0	0	0	0
56	103	0,29	0	125	451,2	0	103	0	0	0	0
59	103	0,29	4800	125	451,2	0	103	0	0	0	0
60	103	0,29	0	125	451,2	0	103	0	0	0	0
21	0	0,00	2400	0	440,2	0	0	0	0	0	0
22	0	0,00	0	0	440,2	0	0	0	0	0	0
23	0	0,00	0	125	451,2	0	0	0	0	0	0
24	0	0,00	0	125	451,2	0	0	0	0	0	0
25	0	0,00	0	125	451,2	0	0	0	0	0	0
26	0	0,00	2400	0	440,2	0	0	0	0	0	0
27	0	0,00	0	0	440,2	0	0	0	0	0	0
28	0	0,00	0	0	429,2	0	0	0	0	0	0
29	0	0,00	2400	1044	127,3	0	0	0	0	0	0
30	0	0,00	0	125	451,2	0	0	0	0	0	0
31	0	0,00	2400	0	429,2	0	0	0	0	0	0
32	0	0,00	2400	0	429,2	0	0	0	0	0	0
33	0	0,00	2400	0	429,2	0	0	0	0	0	0
34	0	0,00	2400	0	440,2	0	0	0	0	0	0
35	0	0,00	2400	0	429,2	0	0	0	0	0	0
36	0	0,00	2400	125	451,2	0	0	0	0	0	0

DODATAK C

Proračun i provjera strukturnih elemenata primjenom DNV 3D-Beam programskog alata

Rešetkasta primarna struktura glavne palube

Beam No.	σ_{eff} [N/mm ²]	Usage	x-pos [mm]	y-pos [mm]	z-pos [mm]	σ_{Nx} [N/mm ²]	σ_{My} [N/mm ²]	σ_{Mz} [N/mm ²]	τ_{Mx} [N/mm ²]	τ_{Qy} [N/mm ²]	τ_{Qz} [N/mm ²]
37	0	0,00	2400	125	451,2	0	0	0	0	0	0
38	0	0,00	0	0	429,2	0	0	0	0	0	0
39	0	0,00	2400	1044	134,3	0	0	0	0	0	0
40	0	0,00	2400	1044	134,3	0	0	0	0	0	0
41	0	0,00	0	0	440,2	0	0	0	0	0	0
42	0	0,00	0	125	451,2	0	0	0	0	0	0
43	0	0,00	0	0	440,2	0	0	0	0	0	0
44	0	0,00	2400	0	440,2	0	0	0	0	0	0

Abbreviations

σ_{eff} : Effective stress according to von Mises, $\sigma_{eff} = \sqrt{(\sigma_{Nx} + \sigma_{My} + \sigma_{Mz})^2 + 3(|\tau_{Mx}| + |\tau_{Qy} + \tau_{Qz}|)^2}$

Usage: Usage factor = $\sigma_{eff} / (\sigma_{yield} / \gamma_M)$

σ_{yield} = specified yield stress

γ_M = material factor = 1.0 unless otherwise specified

Position of stress point where σ_{eff} is computed:

x-pos: Distance from start of beam

y-pos: y-coordinate on profile

z-pos: z-coordinate on profile

Stresses at the stress point:

σ_{Nx} : Axial stress

σ_{My} : Bending stress about local y-axis

σ_{Mz} : Bending stress about local z-axis

τ_{Mx} : Torsional stress

τ_{Qy} : Shear stress in local y-direction

τ_{Qz} : Shear stress in local z-direction

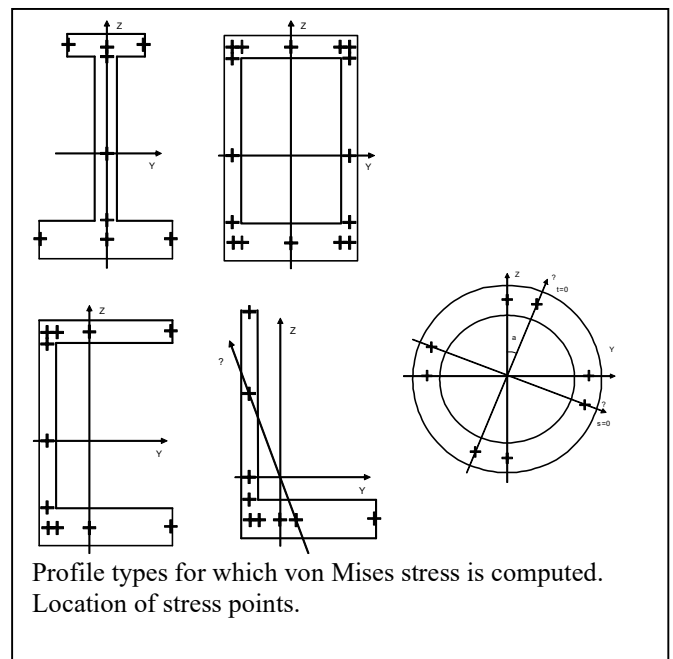

DODATAK D

Proračun i provjera strukturnih elemenata primjenom DNV 3D-Beam programskog alata

Okvir boka garažnog prostora i nadgrađe

Beam information, sorted by Beam in Ascending order

Beam	Beam Name	Start Node	End Node	Elastic Length [mm]	Mass [kg]	Profile	Angle [deg]	Rigid Start [mm]	Rigid End [mm]	Hinged at Start	Hinged at End	Non Linearities
1		3	155	1400	82	23	90,0	0	0			
2		3	5	3600	233	7	0,0	0	0			
3		2	5	2800	136	8	-90,0	0	0			
4		6	146	1400	82	23	-90,0	0	0			
5		6	8	3600	233	7	0,0	0	0			
6		1	8	2800	136	8	90,0	0	0			
7		11	94	2400	328	5	0,0	0	0			
8		12	132	2100	287	5	0,0	0	0			
9		14	154	1400	82	23	90,0	0	0			
10		14	15	3600	233	7	0,0	0	0			
11		13	15	2800	136	8	-90,0	0	0			
12		16	145	1400	82	23	-90,0	0	0			
13		17	127	1500	205	5	0,0	0	0			
14		17	18	2800	136	8	90,0	0	0			
15		16	18	3600	233	7	0,0	0	0			
16		19	197	1800	246	5	0,0	0	0			
17		20	101	2100	287	5	0,0	0	0			
18		22	152	1400	82	23	90,0	0	0			
19		22	23	3600	233	7	0,0	0	0			
20		21	23	2800	136	8	-90,0	0	0			
21		24	143	1400	82	23	-90,0	0	0			
22		25	103	1500	205	5	0,0	0	0			
23		25	26	2800	136	8	90,0	0	0			
24		24	26	3600	233	7	0,0	0	0			
25		27	96	2400	328	5	0,0	0	0			
26		28	100	2100	287	5	0,0	0	0			
27		30	150	1400	82	23	90,0	0	0			
28		30	31	3600	233	7	0,0	0	0			
29		29	31	2800	136	8	-90,0	0	0			
30		32	141	1400	82	23	-90,0	0	0			
31		33	102	1500	205	5	0,0	0	0			
32		33	34	2800	136	8	90,0	0	0			
33		32	34	3600	233	7	0,0	0	0			
34		10	97	2400	986	2	0,0	0	0			
35		9	130	2100	863	2	0,0	0	0			
36		36	148	1400	82	23	90,0	0	0			
37		36	37	3600	233	7	0,0	0	0			
38		35	37	2800	136	8	-90,0	0	0			
39		38	139	1400	82	23	-90,0	0	0			
40		39	126	1500	616	2	0,0	0	0			
41		39	40	2800	136	8	90,0	0	0			
42		38	40	3600	233	7	0,0	0	0			
43		41	153	1400	82	23	90,0	0	0			
44		41	43	3600	233	7	0,0	0	0			
45		44	151	1400	82	23	90,0	0	0			
46		44	46	3600	233	7	0,0	0	0			
47		47	149	1400	82	23	90,0	0	0			
48		47	49	3600	233	7	0,0	0	0			
49		50	147	1400	82	23	90,0	0	0			
50		50	52	3600	233	7	0,0	0	0			
51		53	144	1400	82	23	-90,0	0	0			
52		53	55	3600	233	7	0,0	0	0			
53		56	142	1400	82	23	-90,0	0	0			

DODATAK D

Proračun i provjera strukturnih elemenata primjenom DNV 3D-Beam programskog alata

Okvir boka garažnog prostora i nadgrađe

Beam information, sorted by Beam in Ascending order

Beam	Beam Name	Start Node	End Node	Elastic Length [mm]	Mass [kg]	Profile	Angle [deg]	Rigid Start [mm]	Rigid End [mm]	Hinged at Start	Hinged at End	Non Linearities
54		56	58	3600	233	7	0,0	0	0			
55		59	140	1400	82	23	-90,0	0	0			
56		59	61	3600	233	7	0,0	0	0			
57		62	138	1400	82	23	-90,0	0	0			
58		62	64	3600	233	7	0,0	0	0			
59		65	8	3200	273	6	90,0	0	0			
60		66	55	3200	273	6	90,0	0	0			
61		67	18	3200	273	6	90,0	0	0			
62		68	58	3200	273	6	90,0	0	0			
63		69	26	3200	273	6	90,0	0	0			
64		70	61	3200	273	6	90,0	0	0			
65		71	34	3200	273	6	90,0	0	0			
66		72	64	3200	273	6	90,0	0	0			
67		73	40	3200	794	24	90,0	0	0			
68		74	43	3200	273	6	-90,0	0	0			
69		75	5	3200	273	6	-90,0	0	0			
70		76	15	3200	273	6	-90,0	0	0			
71		77	46	3200	273	6	-90,0	0	0			
72		78	23	3200	273	6	-90,0	0	0			
73		79	49	3200	273	6	-90,0	0	0			
74		80	31	3200	273	6	-90,0	0	0			
75		81	52	3200	273	6	-90,0	0	0			
76		82	37	3200	794	24	-90,0	0	0			
77		83	85	2400	358	9	0,0	0	0			
78		85	89	3000	410	5	0,0	0	0			
79		85	86	2400	358	9	0,0	0	0			
80		86	90	3000	410	5	0,0	0	0			
81		86	87	2400	358	9	0,0	0	0			
82		87	91	3000	410	5	0,0	0	0			
83		87	84	2400	358	9	0,0	0	0			
84		84	92	3000	1233	2	0,0	0	0			
85		88	89	2400	358	9	0,0	0	0			
86		89	12	2400	328	5	0,0	0	0			
87		89	90	2400	358	9	0,0	0	0			
88		90	198	1000	137	5	0,0	0	0			
89		90	91	2400	358	9	0,0	0	0			
90		91	28	2400	328	5	0,0	0	0			
91		91	92	2400	358	9	0,0	0	0			
92		92	9	2400	986	2	0,0	0	0			
93		93	94	2400	358	9	0,0	0	0			
94		94	85	3000	410	5	0,0	0	0			
95		94	95	2400	358	9	0,0	0	0			
96		95	86	3000	410	5	0,0	0	0			
97		95	96	2400	358	9	0,0	0	0			
98		96	87	3000	410	5	0,0	0	0			
99		96	97	2400	358	9	0,0	0	0			
100		97	84	3000	1233	2	0,0	0	0			
101		100	29	1500	205	5	0,0	0	0			
102		101	21	1500	205	5	0,0	0	0			
103		102	27	2100	287	5	0,0	0	0			
104		103	19	2100	287	5	0,0	0	0			
105		106	83	2800	156	12	0,0	0	0			
106		107	199	3500	984	10	0,0	0	0			

DODATAK D

Proračun i provjera strukturnih elemenata primjenom DNV 3D-Beam programskog alata

Okvir boka garažnog prostora i nadgrađe

Beam information, sorted by Beam in Ascending order

Beam	Beam Name	Start Node	End Node	Elastic Length [mm]	Mass [kg]	Profile	Angle [deg]	Rigid Start [mm]	Rigid End [mm]	Hinged at Start	Hinged at End	Non Linearities
107		109	116	3900	1096	10	0,0	0	0			
108		107	101	2800	180	13	-90,0	0	0			
109		109	100	2800	180	13	-90,0	0	0			
110		110	102	2800	180	13	90,0	0	0			
111		108	103	2800	180	13	90,0	0	0			
112		111	113	1200	322	11	0,0	0	0			
113		113	114	1200	322	11	0,0	0	0			
114		114	118	7200	2024	10	0,0	0	0			
115		114	115	2400	643	11	0,0	0	0			
116		115	119	7200	2024	10	0,0	0	0			
117		115	116	2400	643	11	0,0	0	0			
118		116	120	7200	2024	10	0,0	0	0			
119		116	112	2400	643	11	0,0	0	0			
120		105	117	1200	322	11	0,0	0	0			
121		117	118	1200	322	11	0,0	0	0			
122		118	124	3900	1096	10	0,0	0	0			
123		118	119	2400	643	11	0,0	0	0			
124		119	108	3900	1096	10	0,0	0	0			
125		119	104	50	13	11	0,0	0	0			
126		104	120	2350	630	11	0,0	0	0			
127		120	110	3900	1096	10	0,0	0	0			
128		120	121	2400	643	11	0,0	0	0			
129		99	122	2800	156	12	0,0	0	0			
130		125	126	2800	180	13	90,0	0	0			
131		126	10	2100	863	2	0,0	0	0			
132		124	127	2800	180	13	90,0	0	0			
133		127	11	2100	287	5	0,0	0	0			
134		123	128	2800	180	13	90,0	0	0			
135		129	130	2800	180	13	-90,0	0	0			
136		130	35	1500	616	2	0,0	0	0			
137		131	132	2800	180	13	-90,0	0	0			
138		132	13	1500	205	5	0,0	0	0			
139		131	114	3900	1096	10	0,0	0	0			
140		133	134	2800	180	13	-90,0	0	0			
141		98	135	2800	156	12	0,0	0	0			
142		105	135	105	30	10	0,0	0	0			
143		135	123	3795	1067	10	0,0	0	0			
144		123	136	1500	422	10	0,0	0	0			
145		111	106	3600	1012	10	0,0	0	0			
146		106	105	3600	1012	10	0,0	0	0			
147		133	122	3300	928	10	0,0	0	0			
148		122	111	600	169	10	0,0	0	0			
149		137	133	1500	422	10	0,0	0	0			
150		121	125	3900	1096	10	0,0	0	0			
151		112	121	7200	2024	10	0,0	0	0			
152		129	112	3900	1096	10	0,0	0	0			
153		123	195	1200	350	15	0,0	0	0			
154		110	125	2400	699	15	0,0	0	0			
155		108	110	2400	699	15	0,0	0	0			
156		124	108	2400	699	15	0,0	0	0			
157		133	192	1200	350	15	0,0	0	0			
158		131	107	2400	699	15	0,0	0	0			
159		107	109	2400	699	15	0,0	0	0			

DODATAK D

Proračun i provjera strukturnih elemenata primjenom DNV 3D-Beam programskog alata

Okvir boka garažnog prostora i nadgrađe

Beam information, sorted by Beam in Ascending order

Beam	Beam Name	Start Node	End Node	Elastic Length [mm]	Mass [kg]	Profile	Angle [deg]	Rigid Start [mm]	Rigid End [mm]	Hinged at Start	Hinged at End	Non Linearities
160		109	129	2400	699	15	0,0	0	0			
161		138	139	1200	529	4	0,0	0	0			
162		139	10	1400	82	23	-90,0	0	0			
163		138	63	1400	82	23	-90,0	0	0			
164		140	141	1200	529	4	0,0	0	0			
165		141	27	1400	82	23	-90,0	0	0			
166		140	60	1400	82	23	-90,0	0	0			
167		142	143	1200	529	4	0,0	0	0			
168		143	19	1400	82	23	-90,0	0	0			
169		142	57	1400	82	23	-90,0	0	0			
170		144	145	1200	529	4	0,0	0	0			
171		145	11	1400	82	23	-90,0	0	0			
172		144	54	1400	82	23	-90,0	0	0			
173		141	138	1200	529	4	0,0	0	0			
174		143	140	1200	529	4	0,0	0	0			
175		145	142	1200	529	4	0,0	0	0			
176		146	144	1200	529	4	0,0	0	0			
177		146	7	1400	82	23	-90,0	0	0			
178		147	148	1200	529	4	0,0	0	0			
179		148	9	1400	82	23	90,0	0	0			
180		147	51	1400	82	23	90,0	0	0			
181		149	150	1200	529	4	0,0	0	0			
182		150	28	1400	82	23	90,0	0	0			
183		149	48	1400	82	23	90,0	0	0			
184		151	152	1200	529	4	0,0	0	0			
185		152	20	1400	82	23	90,0	0	0			
186		151	45	1400	82	23	90,0	0	0			
187		153	154	1200	529	4	0,0	0	0			
188		154	12	1400	82	23	90,0	0	0			
189		153	42	1400	82	23	90,0	0	0			
190		150	147	1200	529	4	0,0	0	0			
191		152	149	1200	529	4	0,0	0	0			
192		154	151	1200	529	4	0,0	0	0			
193		155	153	1200	529	4	0,0	0	0			
194		155	4	1400	82	23	90,0	0	0			
195		1	156	1200	40	16	0,0	0	0			
196		17	157	1200	40	16	0,0	0	0			
197		25	158	1200	40	16	0,0	0	0			
198		33	159	1200	40	16	0,0	0	0			
199		7	54	1200	40	17	0,0	0	0			
200		11	57	1200	40	17	0,0	0	0			
201		19	60	1200	40	17	0,0	0	0			
202		27	63	1200	40	17	0,0	0	0			
203		63	10	1200	40	17	0,0	0	0			
204		60	27	1200	40	17	0,0	0	0			
205		57	19	1200	40	17	0,0	0	0			
206		54	11	1200	40	17	0,0	0	0			
207		51	9	1200	40	17	0,0	0	0			
208		28	51	1200	40	17	0,0	0	0			
209		48	28	1200	40	17	0,0	0	0			
210		20	48	1200	40	17	0,0	0	0			
211		45	20	1200	40	17	0,0	0	0			
212		12	45	1200	40	17	0,0	0	0			

DODATAK D

Proračun i provjera strukturnih elemenata primjenom DNV 3D-Beam programskog alata

Okvir boka garažnog prostora i nadgrađe

Beam information, sorted by Beam in Ascending order

Beam	Beam Name	Start Node	End Node	Elastic Length [mm]	Mass [kg]	Profile	Angle [deg]	Rigid Start [mm]	Rigid End [mm]	Hinged at Start	Hinged at End	Non Linearities
213		42	12	1200	40	17	0,0	0	0			
214		4	42	1200	40	17	0,0	0	0			
215		29	163	1200	40	16	0,0	0	0			
216		21	162	1200	40	16	0,0	0	0			
217		13	161	1200	40	16	0,0	0	0			
218		2	160	1200	40	16	0,0	0	0			
219		156	55	2800	136	8	90,0	0	0			
220		156	17	1200	40	16	0,0	0	0			
221		157	58	2800	136	8	90,0	0	0			
222		157	25	1200	40	16	0,0	0	0			
223		158	61	2800	136	8	90,0	0	0			
224		158	33	1200	40	16	0,0	0	0			
225		159	64	2800	136	8	90,0	0	0			
226		159	39	1200	40	16	0,0	0	0			
227		160	43	2800	136	8	-90,0	0	0			
228		160	13	1200	40	16	0,0	0	0			
229		161	46	2800	136	8	-90,0	0	0			
230		161	21	1200	40	16	0,0	0	0			
231		162	49	2800	136	8	-90,0	0	0			
232		162	29	1200	40	16	0,0	0	0			
233		163	52	2800	136	8	-90,0	0	0			
234		163	35	1200	40	16	0,0	0	0			
235		164	177	1850	243	18	0,0	0	0			
236		165	164	7200	946	18	0,0	0	0			
237		168	169	1200	610	20	-90,0	0	0			
238		169	137	1200	189	22	0,0	0	0			
239		168	166	1200	610	20	0,0	0	0			
240		170	171	1200	610	20	90,0	0	0			
241		171	136	1200	189	22	0,0	0	0			
242		170	167	1200	610	20	0,0	0	0			
243		172	170	1500	763	20	0,0	0	0			
244		173	178	1850	941	20	0,0	0	0			
245		174	173	7200	3661	20	0,0	0	0			
246		175	180	2050	1042	20	0,0	0	0			
247		168	175	1500	763	20	0,0	0	0			
248		176	165	1850	243	18	0,0	0	0			
249		178	172	2050	1042	20	0,0	0	0			
250		177	178	1200	158	18	0,0	0	0			
251		178	179	1200	610	20	0,0	0	0			
252		176	180	1200	158	18	0,0	0	0			
253		180	174	1850	941	20	0,0	0	0			
254		180	181	1200	610	20	0,0	0	0			
255		182	183	1200	158	18	0,0	0	0			
256		183	184	1200	158	18	0,0	0	0			
257		185	186	1200	158	18	0,0	0	0			
258		187	185	1200	158	18	0,0	0	0			
259		187	188	1850	243	18	0,0	0	0			
260		188	189	7200	946	18	0,0	0	0			
261		189	182	1850	243	18	0,0	0	0			
262		187	176	3000	394	18	-90,0	0	0			
263		182	177	3000	394	18	90,0	0	0			
264		183	178	3000	394	18	90,0	0	0			
265		185	180	3000	394	18	-90,0	0	0			

DODATAK D

Proračun i provjera strukturnih elemenata primjenom DNV 3D-Beam programskog alata

Okvir boka garažnog prostora i nadgrađe

Beam information, sorted by Beam in Ascending order

Beam	Beam Name	Start Node	End Node	Elastic Length [mm]	Mass [kg]	Profile	Angle [deg]	Rigid Start [mm]	Rigid End [mm]	Hinged at Start	Hinged at End	Non Linearities
266		186	181	3000	394	18	-90,0	0	0			
267		184	179	3000	394	18	90,0	0	0			
268		190	184	1850	243	18	0,0	0	0			
269		191	190	7200	946	18	0,0	0	0			
270		186	191	1850	243	18	0,0	0	0			
271		166	181	3550	1805	20	0,0	0	0			
272		179	167	3550	1805	20	0,0	0	0			
273		181	179	10900	5542	20	0,0	0	0			
274		169	192	1500	422	10	0,0	0	0			
275		192	131	1200	350	15	0,0	0	0			
276		193	113	600	169	10	0,0	0	0			
277		192	193	3300	928	10	0,0	0	0			
278		194	117	3600	1012	10	0,0	0	0			
279		113	194	3600	1012	10	0,0	0	0			
280		195	171	1500	422	10	0,0	0	0			
281		195	124	1200	350	15	0,0	0	0			
282		196	195	3795	1067	10	0,0	0	0			
283		117	196	105	30	10	0,0	0	0			
284		136	167	1200	610	20	90,0	0	0			
285		137	166	1200	610	20	-90,0	0	0			
286		2	134	1500	205	5	0,0	0	0			
287		83	93	3000	410	5	0,0	0	0			
288		93	98	705	96	5	0,0	0	0			
289		128	1	1500	205	5	0,0	0	0			
290		98	7	1695	232	5	0,0	0	0			
291		7	128	2100	287	5	0,0	0	0			
292		88	83	3000	410	5	0,0	0	0			
293		99	88	1200	164	5	0,0	0	0			
294		134	4	2100	287	5	0,0	0	0			
295		4	99	1200	164	5	0,0	0	0			
296		119	197	2800	156	12	0,0	0	0			
297		197	95	600	82	5	0,0	0	0			
298		198	199	2800	156	12	0,0	0	0			
299		198	20	1400	191	5	0,0	0	0			
300		199	115	400	112	10	0,0	0	0			
301		40	200	2280,4	171	21	0,0	0	0			
302		39	200	2280,4	171	21	0,0	0	0			
303		200	10	2280,4	171	21	0,0	0	0			
304		200	38	2280,4	171	21	0,0	0	0			
305		9	201	2280,4	171	21	0,0	0	0			
306		36	201	2280,4	171	21	0,0	0	0			
307		201	37	2280,4	171	21	0,0	0	0			
308		201	35	2280,4	171	21	0,0	0	0			
309		202	203	2280,4	171	21	0,0	0	0			
310		202	204	2280,4	171	21	0,0	0	0			
311		205	202	2280,4	171	21	0,0	0	0			
312		206	202	2280,4	171	21	0,0	0	0			
313		207	208	2280,4	171	21	0,0	0	0			
314		207	209	2280,4	171	21	0,0	0	0			
315		210	207	2280,4	171	21	0,0	0	0			
316		211	207	2280,4	171	21	0,0	0	0			
317		212	213	400	112	10	0,0	0	0			
318		214	215	1400	191	5	0,0	0	0			

DODATAK D

Proračun i provjera strukturnih elemenata primjenom DNV 3D-Beam programskog alata

Okvir boka garažnog prostora i nadgrađe

Beam information, sorted by Beam in Ascending order

Beam	Beam Name	Start Node	End Node	Elastic Length [mm]	Mass [kg]	Profile	Angle [deg]	Rigid Start [mm]	Rigid End [mm]	Hinged at Start	Hinged at End	Non Linearities
319		214	212	2800	156	12	0,0	0	0			
320		216	217	600	82	5	0,0	0	0			
321		218	216	2800	156	12	0,0	0	0			
322		219	220	105	30	10	0,0	0	0			
323		220	221	3795	1067	10	0,0	0	0			
324		221	222	1200	350	15	0,0	0	0			
325		221	223	1500	422	10	0,0	0	0			
326		224	225	3600	1012	10	0,0	0	0			
327		225	219	3600	1012	10	0,0	0	0			
328		226	227	3300	928	10	0,0	0	0			
329		227	224	600	169	10	0,0	0	0			
330		226	228	1200	350	15	0,0	0	0			
331		229	226	1500	422	10	0,0	0	0			
332		230	231	3000	394	18	-90,0	0	0			
333		232	233	3000	394	18	90,0	0	0			
334		234	235	3000	394	18	90,0	0	0			
335		236	237	3000	394	18	-90,0	0	0			
336		238	234	1850	243	18	0,0	0	0			
337		239	238	7200	946	18	0,0	0	0			
338		236	239	1850	243	18	0,0	0	0			
339		236	230	1200	158	18	0,0	0	0			
340		230	186	1200	158	18	0,0	0	0			
341		232	184	1200	158	18	0,0	0	0			
342		234	232	1200	158	18	0,0	0	0			
343		231	181	1200	610	20	0,0	0	0			
344		231	240	1850	941	20	0,0	0	0			
345		237	231	1200	158	18	0,0	0	0			
346		233	179	1200	610	20	0,0	0	0			
347		235	233	1200	158	18	0,0	0	0			
348		233	241	2050	1042	20	0,0	0	0			
349		237	242	1850	243	18	0,0	0	0			
350		243	244	1500	763	20	0,0	0	0			
351		244	231	2050	1042	20	0,0	0	0			
352		240	245	7200	3661	20	0,0	0	0			
353		245	233	1850	941	20	0,0	0	0			
354		241	246	1500	763	20	0,0	0	0			
355		246	167	1200	610	20	0,0	0	0			
356		223	136	1200	189	22	0,0	0	0			
357		246	223	1200	610	20	90,0	0	0			
358		243	166	1200	610	20	0,0	0	0			
359		229	137	1200	189	22	0,0	0	0			
360		243	229	1200	610	20	-90,0	0	0			
361		242	247	7200	946	18	0,0	0	0			
362		247	235	1850	243	18	0,0	0	0			
363		248	203	1200	40	16	0,0	0	0			
364		248	249	2800	136	8	-90,0	0	0			
365		250	251	1200	40	16	0,0	0	0			
366		250	252	2800	136	8	-90,0	0	0			
367		253	254	1200	40	16	0,0	0	0			
368		253	255	2800	136	8	-90,0	0	0			
369		256	257	1200	40	16	0,0	0	0			
370		256	258	2800	136	8	-90,0	0	0			
371		259	210	1200	40	16	0,0	0	0			

DODATAK D

Proračun i provjera strukturnih elemenata primjenom DNV 3D-Beam programskog alata

Okvir boka garažnog prostora i nadgrađe

Beam information, sorted by Beam in Ascending order

Beam	Beam Name	Start Node	End Node	Elastic Length [mm]	Mass [kg]	Profile	Angle [deg]	Rigid Start [mm]	Rigid End [mm]	Hinged at Start	Hinged at End	Non Linearities
372		259	260	2800	136	8	90,0	0	0			
373		261	262	1200	40	16	0,0	0	0			
374		261	263	2800	136	8	90,0	0	0			
375		264	265	1200	40	16	0,0	0	0			
376		264	266	2800	136	8	90,0	0	0			
377		267	268	1200	40	16	0,0	0	0			
378		267	269	2800	136	8	90,0	0	0			
379		2	256	1200	40	16	0,0	0	0			
380		257	253	1200	40	16	0,0	0	0			
381		254	250	1200	40	16	0,0	0	0			
382		251	248	1200	40	16	0,0	0	0			
383		4	270	1200	40	17	0,0	0	0			
384		270	271	1200	40	17	0,0	0	0			
385		271	272	1200	40	17	0,0	0	0			
386		272	215	1200	40	17	0,0	0	0			
387		215	273	1200	40	17	0,0	0	0			
388		273	274	1200	40	17	0,0	0	0			
389		274	275	1200	40	17	0,0	0	0			
390		275	206	1200	40	17	0,0	0	0			
391		276	277	1200	40	17	0,0	0	0			
392		278	279	1200	40	17	0,0	0	0			
393		280	281	1200	40	17	0,0	0	0			
394		282	209	1200	40	17	0,0	0	0			
395		281	282	1200	40	17	0,0	0	0			
396		279	280	1200	40	17	0,0	0	0			
397		277	278	1200	40	17	0,0	0	0			
398		7	276	1200	40	17	0,0	0	0			
399		262	259	1200	40	16	0,0	0	0			
400		265	261	1200	40	16	0,0	0	0			
401		268	264	1200	40	16	0,0	0	0			
402		1	267	1200	40	16	0,0	0	0			
403		155	283	1200	529	4	0,0	0	0			
404		284	285	1200	529	4	0,0	0	0			
405		286	287	1200	529	4	0,0	0	0			
406		288	289	1200	529	4	0,0	0	0			
407		283	270	1400	82	23	90,0	0	0			
408		284	271	1400	82	23	90,0	0	0			
409		283	284	1200	529	4	0,0	0	0			
410		285	272	1400	82	23	90,0	0	0			
411		286	215	1400	82	23	90,0	0	0			
412		285	286	1200	529	4	0,0	0	0			
413		287	273	1400	82	23	90,0	0	0			
414		288	274	1400	82	23	90,0	0	0			
415		287	288	1200	529	4	0,0	0	0			
416		289	275	1400	82	23	90,0	0	0			
417		290	206	1400	82	23	90,0	0	0			
418		289	290	1200	529	4	0,0	0	0			
419		146	291	1200	529	4	0,0	0	0			
420		292	293	1200	529	4	0,0	0	0			
421		294	295	1200	529	4	0,0	0	0			
422		296	297	1200	529	4	0,0	0	0			
423		291	276	1400	82	23	-90,0	0	0			
424		292	277	1400	82	23	-90,0	0	0			

DODATAK D

Proračun i provjera strukturnih elemenata primjenom DNV 3D-Beam programskog alata

Okvir boka garažnog prostora i nadgrađe

Beam information, sorted by Beam in Ascending order

Beam	Beam Name	Start Node	End Node	Elastic Length [mm]	Mass [kg]	Profile	Angle [deg]	Rigid Start [mm]	Rigid End [mm]	Hinged at Start	Hinged at End	Non Linearities
425		291	292	1200	529	4	0,0	0	0			
426		293	278	1400	82	23	-90,0	0	0			
427		294	279	1400	82	23	-90,0	0	0			
428		293	294	1200	529	4	0,0	0	0			
429		295	280	1400	82	23	-90,0	0	0			
430		296	281	1400	82	23	-90,0	0	0			
431		295	296	1200	529	4	0,0	0	0			
432		297	282	1400	82	23	-90,0	0	0			
433		298	209	1400	82	23	-90,0	0	0			
434		297	298	1200	529	4	0,0	0	0			
435		299	300	2400	699	15	0,0	0	0			
436		301	299	2400	699	15	0,0	0	0			
437		228	301	2400	699	15	0,0	0	0			
438		133	226	1200	350	15	0,0	0	0			
439		222	302	2400	699	15	0,0	0	0			
440		302	303	2400	699	15	0,0	0	0			
441		303	304	2400	699	15	0,0	0	0			
442		123	221	1200	350	15	0,0	0	0			
443		300	305	3900	1096	10	0,0	0	0			
444		305	306	7200	2024	10	0,0	0	0			
445		306	304	3900	1096	10	0,0	0	0			
446		228	307	3900	1096	10	0,0	0	0			
447		308	257	1500	205	5	0,0	0	0			
448		228	308	2800	180	13	-90,0	0	0			
449		309	203	1500	616	2	0,0	0	0			
450		300	309	2800	180	13	-90,0	0	0			
451		310	277	2100	287	5	0,0	0	0			
452		222	310	2800	180	13	90,0	0	0			
453		311	209	2100	863	2	0,0	0	0			
454		304	311	2800	180	13	90,0	0	0			
455		312	306	2400	643	11	0,0	0	0			
456		312	303	3900	1096	10	0,0	0	0			
457		313	312	2350	630	11	0,0	0	0			
458		218	313	50	13	11	0,0	0	0			
459		218	302	3900	1096	10	0,0	0	0			
460		314	218	2400	643	11	0,0	0	0			
461		314	222	3900	1096	10	0,0	0	0			
462		219	314	1200	322	11	0,0	0	0			
463		105	219	1200	322	11	0,0	0	0			
464		315	305	2400	643	11	0,0	0	0			
465		315	312	7200	2024	10	0,0	0	0			
466		213	315	2400	643	11	0,0	0	0			
467		213	218	7200	2024	10	0,0	0	0			
468		307	213	2400	643	11	0,0	0	0			
469		307	314	7200	2024	10	0,0	0	0			
470		224	307	1200	322	11	0,0	0	0			
471		111	224	1200	322	11	0,0	0	0			
472		302	316	2800	180	13	90,0	0	0			
473		303	317	2800	180	13	90,0	0	0			
474		299	318	2800	180	13	-90,0	0	0			
475		301	319	2800	180	13	-90,0	0	0			
476		299	315	3900	1096	10	0,0	0	0			
477		301	212	3500	984	10	0,0	0	0			

DODATAK D

Proračun i provjera strukturnih elemenata primjenom DNV 3D-Beam programskog alata

Okvir boka garažnog prostora i nadgrađe

Beam information, sorted by Beam in Ascending order

Beam	Beam Name	Start Node	End Node	Elastic Length [mm]	Mass [kg]	Profile	Angle [deg]	Rigid Start [mm]	Rigid End [mm]	Hinged at Start	Hinged at End	Non Linearities
478		316	279	2100	287	5	0,0	0	0			
479		317	281	2100	287	5	0,0	0	0			
480		319	254	1500	205	5	0,0	0	0			
481		318	251	1500	205	5	0,0	0	0			
482		320	321	3000	1233	2	0,0	0	0			
483		322	320	2400	358	9	0,0	0	0			
484		322	323	3000	410	5	0,0	0	0			
485		217	322	2400	358	9	0,0	0	0			
486		217	324	3000	410	5	0,0	0	0			
487		325	217	2400	358	9	0,0	0	0			
488		325	326	3000	410	5	0,0	0	0			
489		93	325	2400	358	9	0,0	0	0			
490		327	206	2400	986	2	0,0	0	0			
491		328	327	2400	358	9	0,0	0	0			
492		328	274	2400	328	5	0,0	0	0			
493		329	328	2400	358	9	0,0	0	0			
494		329	214	1000	137	5	0,0	0	0			
495		330	329	2400	358	9	0,0	0	0			
496		330	271	2400	328	5	0,0	0	0			
497		88	330	2400	358	9	0,0	0	0			
498		321	327	3000	1233	2	0,0	0	0			
499		323	321	2400	358	9	0,0	0	0			
500		323	328	3000	410	5	0,0	0	0			
501		324	323	2400	358	9	0,0	0	0			
502		324	329	3000	410	5	0,0	0	0			
503		326	324	2400	358	9	0,0	0	0			
504		326	330	3000	410	5	0,0	0	0			
505		83	326	2400	358	9	0,0	0	0			
506		331	204	3200	794	24	-90,0	0	0			
507		332	249	3200	273	6	-90,0	0	0			
508		333	334	3200	273	6	-90,0	0	0			
509		335	252	3200	273	6	-90,0	0	0			
510		336	337	3200	273	6	-90,0	0	0			
511		338	255	3200	273	6	-90,0	0	0			
512		339	340	3200	273	6	-90,0	0	0			
513		341	258	3200	273	6	-90,0	0	0			
514		342	211	3200	794	24	90,0	0	0			
515		343	260	3200	273	6	90,0	0	0			
516		344	345	3200	273	6	90,0	0	0			
517		346	263	3200	273	6	90,0	0	0			
518		347	348	3200	273	6	90,0	0	0			
519		349	266	3200	273	6	90,0	0	0			
520		350	351	3200	273	6	90,0	0	0			
521		352	269	3200	273	6	90,0	0	0			
522		353	260	3600	233	7	0,0	0	0			
523		353	297	1400	82	23	-90,0	0	0			
524		354	263	3600	233	7	0,0	0	0			
525		354	295	1400	82	23	-90,0	0	0			
526		355	266	3600	233	7	0,0	0	0			
527		355	293	1400	82	23	-90,0	0	0			
528		356	269	3600	233	7	0,0	0	0			
529		356	291	1400	82	23	-90,0	0	0			
530		357	249	3600	233	7	0,0	0	0			

DODATAK D

Proračun i provjera strukturnih elemenata primjenom DNV 3D-Beam programskog alata

Okvir boka garažnog prostora i nadgrađe

Beam information, sorted by Beam in Ascending order

Beam	Beam Name	Start Node	End Node	Elastic Length [mm]	Mass [kg]	Profile	Angle [deg]	Rigid Start [mm]	Rigid End [mm]	Hinged at Start	Hinged at End	Non Linearities
531		357	289	1400	82	23	90,0	0	0			
532		358	252	3600	233	7	0,0	0	0			
533		358	287	1400	82	23	90,0	0	0			
534		359	255	3600	233	7	0,0	0	0			
535		359	285	1400	82	23	90,0	0	0			
536		360	258	3600	233	7	0,0	0	0			
537		360	283	1400	82	23	90,0	0	0			
538		208	211	3600	233	7	0,0	0	0			
539		210	211	2800	136	8	90,0	0	0			
540		210	311	1500	616	2	0,0	0	0			
541		208	298	1400	82	23	-90,0	0	0			
542		203	204	2800	136	8	-90,0	0	0			
543		205	204	3600	233	7	0,0	0	0			
544		205	290	1400	82	23	90,0	0	0			
545		206	309	2100	863	2	0,0	0	0			
546		209	320	2400	986	2	0,0	0	0			
547		361	345	3600	233	7	0,0	0	0			
548		262	345	2800	136	8	90,0	0	0			
549		262	317	1500	205	5	0,0	0	0			
550		361	296	1400	82	23	-90,0	0	0			
551		251	334	2800	136	8	-90,0	0	0			
552		362	334	3600	233	7	0,0	0	0			
553		362	288	1400	82	23	90,0	0	0			
554		274	318	2100	287	5	0,0	0	0			
555		281	322	2400	328	5	0,0	0	0			
556		363	348	3600	233	7	0,0	0	0			
557		265	348	2800	136	8	90,0	0	0			
558		265	316	1500	205	5	0,0	0	0			
559		363	294	1400	82	23	-90,0	0	0			
560		254	337	2800	136	8	-90,0	0	0			
561		364	337	3600	233	7	0,0	0	0			
562		364	286	1400	82	23	90,0	0	0			
563		215	319	2100	287	5	0,0	0	0			
564		279	216	1800	246	5	0,0	0	0			
565		365	351	3600	233	7	0,0	0	0			
566		268	351	2800	136	8	90,0	0	0			
567		268	310	1500	205	5	0,0	0	0			
568		365	292	1400	82	23	-90,0	0	0			
569		257	340	2800	136	8	-90,0	0	0			
570		366	340	3600	233	7	0,0	0	0			
571		366	284	1400	82	23	90,0	0	0			
572		271	308	2100	287	5	0,0	0	0			
573		277	325	2400	328	5	0,0	0	0			
574		125	367	7629,5	574	21	0,0	0	0			
575		129	367	7629,5	574	21	0,0	0	0			
576		367	130	7629,5	574	21	0,0	0	0			
577		367	126	7629,5	574	21	0,0	0	0			
578		304	368	7629,5	574	21	0,0	0	0			
579		368	311	7629,5	574	21	0,0	0	0			
580		368	309	7629,5	574	21	0,0	0	0			
581		300	368	7629,5	574	21	0,0	0	0			
582		211	260	1200	91	26	90,0	0	0			
583		8	55	1200	91	26	90,0	0	0			

DODATAK D

Proračun i provjera strukturnih elemenata primjenom DNV 3D-Beam programskog alata

Okvir boka garažnog prostora i nadgrađe

Beam information, sorted by Beam in Ascending order

Beam	Beam Name	Start Node	End Node	Elastic Length [mm]	Mass [kg]	Profile	Angle [deg]	Rigid Start [mm]	Rigid End [mm]	Hinged at Start	Hinged at End	Non Linearities
584		18	58	1200	91	26	90,0	0	0			
585		26	61	1200	91	26	90,0	0	0			
586		34	64	1200	91	26	90,0	0	0			
587		64	40	1200	91	26	90,0	0	0			
588		61	34	1200	91	26	90,0	0	0			
589		58	26	1200	91	26	90,0	0	0			
590		55	18	1200	91	26	90,0	0	0			
591		260	345	1200	91	26	90,0	0	0			
592		263	348	1200	91	26	90,0	0	0			
593		266	351	1200	91	26	90,0	0	0			
594		269	8	1200	91	26	90,0	0	0			
595		351	269	1200	91	26	90,0	0	0			
596		348	266	1200	91	26	90,0	0	0			
597		345	263	1200	91	26	90,0	0	0			
598		255	340	1200	91	26	90,0	0	0			
599		252	337	1200	91	26	90,0	0	0			
600		249	334	1200	91	26	90,0	0	0			
601		31	52	1200	91	26	90,0	0	0			
602		23	49	1200	91	26	90,0	0	0			
603		15	46	1200	91	26	90,0	0	0			
604		5	43	1200	91	26	90,0	0	0			
605		204	249	1200	91	26	90,0	0	0			
606		334	252	1200	91	26	90,0	0	0			
607		337	255	1200	91	26	90,0	0	0			
608		340	258	1200	91	26	90,0	0	0			
609		258	5	1200	91	26	90,0	0	0			
610		43	15	1200	91	26	90,0	0	0			
611		46	23	1200	91	26	90,0	0	0			
612		49	31	1200	91	26	90,0	0	0			
613		52	37	1200	91	26	90,0	0	0			

Abbreviations

Beam information:

Beam: Beam identification number

Beam Name: User's beam identification

Start/End Node: Node numbers for the start and end nodes respectively

Elastic length: Elastic length of beam, excluding possible rigid ends

Mass: Mass of the elastic length of beam

Profile: Profile identification number

Angle: Angle between the profile's z-axis and the plane through the beam and the global Z-axis. Positive for clockwise rotation when seen in positive local x-direction.

Rigid Start/End: Length of possible rigid part of the beam at the start and end ends respectively

Hinged at Start/End: Possibly defined hinge at the start and end nodes respectively, where hinges are defined as:

dX, dY, dZ: Hinged with respect to translation in the global X-, Y-, and Z-direction respectively

rX, rY, rZ: Hinged with respect to rotation about the global X-, Y-, and Z-axis respectively

DODATAK D

Proračun i provjera strukturnih elemenata primjenom DNV 3D-Beam programskog alata

Okvir boka garažnog prostora i nadgrađe

Non Linearities: Possibly specified non-linear properties for the beam. For definition see figure below.

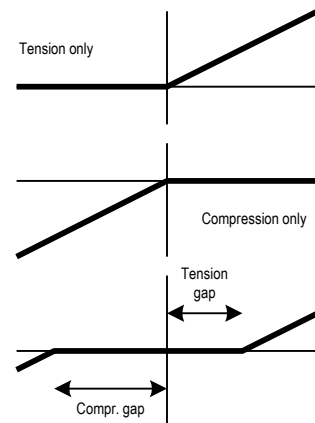

DODATAK D

Proračun i provjera strukturnih elemenata primjenom DNV 3D-Beam programskog alata

Okvir boka garažnog prostora i nadgrađe

Node information, sorted by Node in Ascending order

Node No	Name	X [mm]	Y [mm]	Z [mm]	Boundary Conditions					
					X transl	Y transl	Z transl	X rot	Y rot	Z rot
1		0	-9000	10900						
2		0	9000	10900						
3		0	5400	8100						
4		0	5400	10900						
5		0	9000	8100						
6		0	-5400	8100						
7		0	-5400	10900						
8		0	-9000	8100						
9		9600	5400	10900						
10		9600	-5400	10900						
11		2400	-5400	10900						
12		2400	5400	10900						
13		2400	9000	10900						
14		2400	5400	8100						
15		2400	9000	8100						
16		2400	-5400	8100						
17		2400	-9000	10900						
18		2400	-9000	8100						
19		4800	-5400	10900						
20		4800	5400	10900						
21		4800	9000	10900						
22		4800	5400	8100						
23		4800	9000	8100						
24		4800	-5400	8100						
25		4800	-9000	10900						
26		4800	-9000	8100						

DODATAK D

Proračun i provjera strukturnih elemenata primjenom DNV 3D-Beam programskog alata

Okvir boka garažnog prostora i nadgrađe

Node information, sorted by Node in Ascending order

Node No	Name	X [mm]	Y [mm]	Z [mm]	Boundary Conditions					
					X transl	Y transl	Z transl	X rot	Y rot	Z rot
27		7200	-5400	10900						
28		7200	5400	10900						
29		7200	9000	10900						
30		7200	5400	8100						
31		7200	9000	8100						
32		7200	-5400	8100						
33		7200	-9000	10900						
34		7200	-9000	8100						
35		9600	9000	10900						
36		9600	5400	8100						
37		9600	9000	8100						
38		9600	-5400	8100						
39		9600	-9000	10900						
40		9600	-9000	8100						
41		1200	5400	8100						
42		1200	5400	10900						
43		1200	9000	8100						
44		3600	5400	8100						
45		3600	5400	10900						
46		3600	9000	8100						
47		6000	5400	8100						
48		6000	5400	10900						
49		6000	9000	8100						
50		8400	5400	8100						
51		8400	5400	10900						
52		8400	9000	8100						

DODATAK D

Proračun i provjera strukturnih elemenata primjenom DNV 3D-Beam programskog alata

Okvir boka garažnog prostora i nadgrađe

Node information, sorted by Node in Ascending order

Node No	Name	X [mm]	Y [mm]	Z [mm]	Boundary Conditions					
					X transl	Y transl	Z transl	X rot	Y rot	Z rot
53		1200	-5400	8100						
54		1200	-5400	10900						
55		1200	-9000	8100						
56		3600	-5400	8100						
57		3600	-5400	10900						
58		3600	-9000	8100						
59		6000	-5400	8100						
60		6000	-5400	10900						
61		6000	-9000	8100						
62		8400	-5400	8100						
63		8400	-5400	10900						
64		8400	-9000	8100						
65		0	-9000	4900	Fixed	Fixed	Fixed	Fixed	Fixed	Fixed
66		1200	-9000	4900	Fixed	Fixed	Fixed	Fixed	Free	Free
67		2400	-9000	4900	Fixed	Fixed	Fixed	Fixed	Fixed	Fixed
68		3600	-9000	4900	Fixed	Fixed	Fixed	Fixed	Free	Free
69		4800	-9000	4900	Fixed	Fixed	Fixed	Fixed	Fixed	Fixed
70		6000	-9000	4900	Fixed	Fixed	Fixed	Fixed	Free	Free
71		7200	-9000	4900	Fixed	Fixed	Fixed	Fixed	Fixed	Fixed
72		8400	-9000	4900	Fixed	Fixed	Fixed	Fixed	Free	Free
73		9600	-9000	4900	Fixed	Fixed	Fixed	Fixed	Fixed	Fixed
74		1200	9000	4900	Fixed	Fixed	Fixed	Fixed	Free	Free
75		0	9000	4900	Fixed	Fixed	Fixed	Fixed	Fixed	Fixed
76		2400	9000	4900	Fixed	Fixed	Fixed	Fixed	Fixed	Fixed
77		3600	9000	4900	Fixed	Fixed	Fixed	Fixed	Free	Free
78		4800	9000	4900	Fixed	Fixed	Fixed	Fixed	Fixed	Fixed

DODATAK D

Proračun i provjera strukturnih elemenata primjenom DNV 3D-Beam programskog alata

Okvir boka garažnog prostora i nadgrađe

Node information, sorted by Node in Ascending order

Node No	Name	X [mm]	Y [mm]	Z [mm]	Boundary Conditions					
					X transl	Y transl	Z transl	X rot	Y rot	Z rot
79		6000	9000	4900	Fixed	Fixed	Fixed	Fixed	Free	Free
80		7200	9000	4900	Fixed	Fixed	Fixed	Fixed	Fixed	Fixed
81		8400	9000	4900	Fixed	Fixed	Fixed	Fixed	Free	Free
82		9600	9000	4900	Fixed	Fixed	Fixed	Fixed	Fixed	Fixed
83		0	0	10900						
84		9600	0	10900						
85		2400	0	10900						
86		4800	0	10900						
87		7200	0	10900						
88		0	3000	10900						
89		2400	3000	10900						
90		4800	3000	10900						
91		7200	3000	10900						
92		9600	3000	10900						
93		0	-3000	10900						
94		2400	-3000	10900						
95		4800	-3000	10900						
96		7200	-3000	10900						
97		9600	-3000	10900						
98		0	-3705	10900						
99		0	4200	10900						
100		7200	7500	10900						
101		4800	7500	10900						
102		7200	-7500	10900						
103		4800	-7500	10900						
104		4850	-3600	13700						

DODATAK D

Proračun i provjera strukturnih elemenata primjenom DNV 3D-Beam programskog alata

Okvir boka garažnog prostora i nadgrađe

Node information, sorted by Node in Ascending order

Node No	Name	X [mm]	Y [mm]	Z [mm]	Boundary Conditions					
					X transl	Y transl	Z transl	X rot	Y rot	Z rot
105		0	-3600	13700						
106		0	0	13700						
107		4800	7500	13700						
108		4800	-7500	13700						
109		7200	7500	13700						
110		7200	-7500	13700						
111		0	3600	13700						
112		9600	3600	13700						
113		1200	3600	13700						
114		2400	3600	13700						
115		4800	3600	13700						
116		7200	3600	13700						
117		1200	-3600	13700						
118		2400	-3600	13700						
119		4800	-3600	13700						
120		7200	-3600	13700						
121		9600	-3600	13700						
122		0	4200	13700						
123		0	-7500	13700						
124		2400	-7500	13700						
125		9600	-7500	13700						
126		9600	-7500	10900						
127		2400	-7500	10900						
128		0	-7500	10900						
129		9600	7500	13700						
130		9600	7500	10900						

DODATAK D

Proračun i provjera strukturnih elemenata primjenom DNV 3D-Beam programskog alata

Okvir boka garažnog prostora i nadgrađe

Node information, sorted by Node in Ascending order

Node No	Name	X [mm]	Y [mm]	Z [mm]	Boundary Conditions					
					X transl	Y transl	Z transl	X rot	Y rot	Z rot
131		2400	7500	13700						
132		2400	7500	10900						
133		0	7500	13700						
134		0	7500	10900						
135		0	-3705	13700						
136		0	-9000	13700						
137		0	9000	13700						
138		8400	-5400	9500						
139		9600	-5400	9500						
140		6000	-5400	9500						
141		7200	-5400	9500						
142		3600	-5400	9500						
143		4800	-5400	9500						
144		1200	-5400	9500						
145		2400	-5400	9500						
146		0	-5400	9500						
147		8400	5400	9500						
148		9600	5400	9500						
149		6000	5400	9500						
150		7200	5400	9500						
151		3600	5400	9500						
152		4800	5400	9500						
153		1200	5400	9500						
154		2400	5400	9500						
155		0	5400	9500						
156		1200	-9000	10900						

DODATAK D

Proračun i provjera strukturnih elemenata primjenom DNV 3D-Beam programskog alata

Okvir boka garažnog prostora i nadgrađe

Node information, sorted by Node in Ascending order

Node No	Name	X [mm]	Y [mm]	Z [mm]	Boundary Conditions					
					X transl	Y transl	Z transl	X rot	Y rot	Z rot
157		3600	-9000	10900						
158		6000	-9000	10900						
159		8400	-9000	10900						
160		1200	9000	10900						
161		3600	9000	10900						
162		6000	9000	10900						
163		8400	9000	10900						
164		2400	-3600	14900						
165		2400	3600	14900						
166		0	9000	14900						
167		0	-9000	14900						
168		1200	9000	14900						
169		1200	9000	13700						
170		1200	-9000	14900						
171		1200	-9000	13700						
172		1200	-7500	14900						
173		1200	-3600	14900						
174		1200	3600	14900						
175		1200	7500	14900						
176		2400	5450	14900						
177		2400	-5450	14900						
178		1200	-5450	14900						
179		0	-5450	14900						
180		1200	5450	14900						
181		0	5450	14900						
182		2400	-5450	17900						

DODATAK D

Proračun i provjera strukturnih elemenata primjenom DNV 3D-Beam programskog alata

Okvir boka garažnog prostora i nadgrađe

Node information, sorted by Node in Ascending order

Node No	Name	X [mm]	Y [mm]	Z [mm]	Boundary Conditions					
					X transl	Y transl	Z transl	X rot	Y rot	Z rot
183		1200	-5450	17900						
184		0	-5450	17900						
185		1200	5450	17900						
186		0	5450	17900						
187		2400	5450	17900						
188		2400	3600	17900						
189		2400	-3600	17900						
190		0	-3600	17900						
191		0	3600	17900						
192		1200	7500	13700						
193		1200	4200	13700						
194		1200	0	13700						
195		1200	-7500	13700						
196		1200	-3705	13700						
197		4800	-3600	10900						
198		4800	4000	10900						
199		4800	4000	13700						
200		9600	-7200	9500						
201		9600	7200	9500						
202		-9600	7200	9500						
203		-9600	9000	10900						
204		-9600	9000	8100						
205		-9600	5400	8100						
206		-9600	5400	10900						
207		-9600	-7200	9500						
208		-9600	-5400	8100						

DODATAK D

Proračun i provjera strukturnih elemenata primjenom DNV 3D-Beam programskog alata

Okvir boka garažnog prostora i nadgrađe

Node information, sorted by Node in Ascending order

Node No	Name	X [mm]	Y [mm]	Z [mm]	Boundary Conditions					
					X transl	Y transl	Z transl	X rot	Y rot	Z rot
209		-9600	-5400	10900						
210		-9600	-9000	10900						
211		-9600	-9000	8100						
212		-4800	4000	13700						
213		-4800	3600	13700						
214		-4800	4000	10900						
215		-4800	5400	10900						
216		-4800	-3600	10900						
217		-4800	-3000	10900						
218		-4800	-3600	13700						
219		-1200	-3600	13700						
220		-1200	-3705	13700						
221		-1200	-7500	13700						
222		-2400	-7500	13700						
223		-1200	-9000	13700						
224		-1200	3600	13700						
225		-1200	0	13700						
226		-1200	7500	13700						
227		-1200	4200	13700						
228		-2400	7500	13700						
229		-1200	9000	13700						
230		-1200	5450	17900						
231		-1200	5450	14900						
232		-1200	-5450	17900						
233		-1200	-5450	14900						
234		-2400	-5450	17900						

DODATAK D

Proračun i provjera strukturnih elemenata primjenom DNV 3D-Beam programskog alata

Okvir boka garažnog prostora i nadgrađe

Node information, sorted by Node in Ascending order

Node No	Name	X [mm]	Y [mm]	Z [mm]	Boundary Conditions					
					X transl	Y transl	Z transl	X rot	Y rot	Z rot
235		-2400	-5450	14900						
236		-2400	5450	17900						
237		-2400	5450	14900						
238		-2400	-3600	17900						
239		-2400	3600	17900						
240		-1200	3600	14900						
241		-1200	-7500	14900						
242		-2400	3600	14900						
243		-1200	9000	14900						
244		-1200	7500	14900						
245		-1200	-3600	14900						
246		-1200	-9000	14900						
247		-2400	-3600	14900						
248		-8400	9000	10900						
249		-8400	9000	8100						
250		-6000	9000	10900						
251		-7200	9000	10900						
252		-6000	9000	8100						
253		-3600	9000	10900						
254		-4800	9000	10900						
255		-3600	9000	8100						
256		-1200	9000	10900						
257		-2400	9000	10900						
258		-1200	9000	8100						
259		-8400	-9000	10900						
260		-8400	-9000	8100						

DODATAK D

Proračun i provjera strukturnih elemenata primjenom DNV 3D-Beam programskog alata

Okvir boka garažnog prostora i nadgrađe

Node information, sorted by Node in Ascending order

Node No	Name	X [mm]	Y [mm]	Z [mm]	Boundary Conditions					
					X transl	Y transl	Z transl	X rot	Y rot	Z rot
261		-6000	-9000	10900						
262		-7200	-9000	10900						
263		-6000	-9000	8100						
264		-3600	-9000	10900						
265		-4800	-9000	10900						
266		-3600	-9000	8100						
267		-1200	-9000	10900						
268		-2400	-9000	10900						
269		-1200	-9000	8100						
270		-1200	5400	10900						
271		-2400	5400	10900						
272		-3600	5400	10900						
273		-6000	5400	10900						
274		-7200	5400	10900						
275		-8400	5400	10900						
276		-1200	-5400	10900						
277		-2400	-5400	10900						
278		-3600	-5400	10900						
279		-4800	-5400	10900						
280		-6000	-5400	10900						
281		-7200	-5400	10900						
282		-8400	-5400	10900						
283		-1200	5400	9500						
284		-2400	5400	9500						
285		-3600	5400	9500						
286		-4800	5400	9500						

DODATAK D

Proračun i provjera strukturnih elemenata primjenom DNV 3D-Beam programskog alata

Okvir boka garažnog prostora i nadgrađe

Node information, sorted by Node in Ascending order

Node No	Name	X [mm]	Y [mm]	Z [mm]	Boundary Conditions					
					X transl	Y transl	Z transl	X rot	Y rot	Z rot
287		-6000	5400	9500						
288		-7200	5400	9500						
289		-8400	5400	9500						
290		-9600	5400	9500						
291		-1200	-5400	9500						
292		-2400	-5400	9500						
293		-3600	-5400	9500						
294		-4800	-5400	9500						
295		-6000	-5400	9500						
296		-7200	-5400	9500						
297		-8400	-5400	9500						
298		-9600	-5400	9500						
299		-7200	7500	13700						
300		-9600	7500	13700						
301		-4800	7500	13700						
302		-4800	-7500	13700						
303		-7200	-7500	13700						
304		-9600	-7500	13700						
305		-9600	3600	13700						
306		-9600	-3600	13700						
307		-2400	3600	13700						
308		-2400	7500	10900						
309		-9600	7500	10900						
310		-2400	-7500	10900						
311		-9600	-7500	10900						
312		-7200	-3600	13700						

DODATAK D

Proračun i provjera strukturnih elemenata primjenom DNV 3D-Beam programskog alata

Okvir boka garažnog prostora i nadgrađe

Node information, sorted by Node in Ascending order

Node No	Name	X [mm]	Y [mm]	Z [mm]	Boundary Conditions					
					X transl	Y transl	Z transl	X rot	Y rot	Z rot
313		-4850	-3600	13700						
314		-2400	-3600	13700						
315		-7200	3600	13700						
316		-4800	-7500	10900						
317		-7200	-7500	10900						
318		-7200	7500	10900						
319		-4800	7500	10900						
320		-9600	-3000	10900						
321		-9600	0	10900						
322		-7200	-3000	10900						
323		-7200	0	10900						
324		-4800	0	10900						
325		-2400	-3000	10900						
326		-2400	0	10900						
327		-9600	3000	10900						
328		-7200	3000	10900						
329		-4800	3000	10900						
330		-2400	3000	10900						
331		-9600	9000	4900	Fixed	Fixed	Fixed	Fixed	Fixed	Fixed
332		-8400	9000	4900	Fixed	Fixed	Fixed	Fixed	Free	Free
333		-7200	9000	4900	Fixed	Fixed	Fixed	Fixed	Fixed	Fixed
334		-7200	9000	8100						
335		-6000	9000	4900	Fixed	Fixed	Fixed	Fixed	Free	Free
336		-4800	9000	4900	Fixed	Fixed	Fixed	Fixed	Fixed	Fixed
337		-4800	9000	8100						
338		-3600	9000	4900	Fixed	Fixed	Fixed	Fixed	Free	Free

DODATAK D

Proračun i provjera strukturnih elemenata primjenom DNV 3D-Beam programskog alata

Okvir boka garažnog prostora i nadgrađe

Node information, sorted by Node in Ascending order

Node No	Name	X [mm]	Y [mm]	Z [mm]	Boundary Conditions					
					X transl	Y transl	Z transl	X rot	Y rot	Z rot
339		-2400	9000	4900	Fixed	Fixed	Fixed	Fixed	Fixed	Fixed
340		-2400	9000	8100						
341		-1200	9000	4900	Fixed	Fixed	Fixed	Fixed	Free	Free
342		-9600	-9000	4900	Fixed	Fixed	Fixed	Fixed	Fixed	Fixed
343		-8400	-9000	4900	Fixed	Fixed	Fixed	Fixed	Free	Free
344		-7200	-9000	4900	Fixed	Fixed	Fixed	Fixed	Fixed	Fixed
345		-7200	-9000	8100						
346		-6000	-9000	4900	Fixed	Fixed	Fixed	Fixed	Free	Free
347		-4800	-9000	4900	Fixed	Fixed	Fixed	Fixed	Fixed	Fixed
348		-4800	-9000	8100						
349		-3600	-9000	4900	Fixed	Fixed	Fixed	Fixed	Free	Free
350		-2400	-9000	4900	Fixed	Fixed	Fixed	Fixed	Fixed	Fixed
351		-2400	-9000	8100						
352		-1200	-9000	4900	Fixed	Fixed	Fixed	Fixed	Free	Free
353		-8400	-5400	8100						
354		-6000	-5400	8100						
355		-3600	-5400	8100						
356		-1200	-5400	8100						
357		-8400	5400	8100						
358		-6000	5400	8100						
359		-3600	5400	8100						
360		-1200	5400	8100						
361		-7200	-5400	8100						
362		-7200	5400	8100						
363		-4800	-5400	8100						
364		-4800	5400	8100						

DODATAK D

Proračun i provjera strukturnih elemenata primjenom DNV 3D-Beam programskog alata

Okvir boka garažnog prostora i nadgrađe

Node information, sorted by Node in Ascending order

Node No	Name	X [mm]	Y [mm]	Z [mm]	Boundary Conditions					
					X transl	Y transl	Z transl	X rot	Y rot	Z rot
365		-2400	-5400	8100						
366		-2400	5400	8100						
367		9600	0	12300						
368		-9600	0	12300						

Abbreviations

Node No: Node identification number
Name: User's node identification
X, Y, Z: Node coordinates in the global coordinate system
X transl, Y transl, Z transl: Boundary conditions w.r.t. translation along the global axes
X rot, Y rot, Zrot: Boundary conditions w.r.t. rotation about the global axes

Where:

Free: The node is free
Fixed: The node is fixed
FD: The node has a prescribed displacement or rotation
Spring: The node is supported by a spring

DODATAK D

Proračun i provjera strukturnih elemenata primjenom DNV 3D-Beam programskog alata

Okvir boka garažnog prostora i nadgrađe

Profiles used in the model

Profiles

Profile	Profile Name	Type	Material	Ignore S. C.	Shear factor fy	Shear factor fz	Profile parameters
2	Poprečna pregrada R16 i R-16	40	9 Gl.paluba - Paluba 4		1,00	1,00	Effective plate Width=3000 [mm], Plate Thickness, pT=7 [mm], Web Height, hw=2200 [mm], Web Thickness, t=7 [mm], Flange width (incl. web), bf=3000 [mm], Flange thickness, tf=7 [mm], Angle Between Profile & Plate=90 [Degrees], FlipY=True, NeglectIlyz=True
4	Uzdužna pregrada	40	9 Gl.paluba - Paluba 4		1,00	1,00	Effective plate Width=3000 [mm], Plate Thickness, pT=7 [mm], Web Height, hw=2800 [mm], Web Thickness, t=7 [mm], Flange width (incl. web), bf=3000 [mm], Flange thickness, tf=7 [mm], Angle Between Profile & Plate=90 [Degrees], FlipY=True, NeglectIlyz=True
5	Okvirne sponje	40	9 Gl.paluba - Paluba 4		1,00	1,00	Effective plate Width=1440 [mm], Plate Thickness, pT=7 [mm], Web Height, hw=500 [mm], Web Thickness, t=10 [mm], Flange width (incl. web), bf=250 [mm], Flange thickness, tf=15 [mm], Angle Between Profile & Plate=90 [Degrees], FlipY=True, NeglectIlyz=True
6	Rebra oplate u garaži	40	9 Gl.paluba - Paluba 4		1,00	1,00	Effective plate Width=600 [mm], Plate Thickness, pT=8 [mm], Web Height, hw=280 [mm], Web Thickness, t=10 [mm], Flange width (incl. web), bf=200 [mm], Flange thickness, tf=20 [mm], Angle Between Profile & Plate=90 [Degrees], FlipY=True, FlipZ=True, NeglectIlyz=True
7	Paluba 3 - 8100	40	10 Paluba 3 (AH 36)		1,00	1,00	Effective plate Width=720 [mm], Plate Thickness, pT=7 [mm], Web Height, hw=190 [mm], Web Thickness, t=10 [mm], Flange width (incl. web), bf=200 [mm], Flange thickness, tf=10 [mm], Angle Between Profile & Plate=90 [Degrees], FlipZ=True, NeglectIlyz=True
8	Rebra u salonu	40	9 Gl.paluba - Paluba 4		1,00	1,00	Effective plate Width=450 [mm], Plate Thickness, pT=7 [mm], Web Height, hw=125 [mm], Web Thickness, t=10 [mm], Flange width (incl. web), bf=150 [mm], Flange thickness, tf=15 [mm], Angle Between Profile & Plate=90 [Degrees], FlipY=True, FlipZ=True, NeglectIlyz=True
9	Paluba 4 - 10900	40	9 Gl.paluba - Paluba 4		1,00	1,00	Effective plate Width=1800 [mm], Plate Thickness, pT=7 [mm], Web Height, hw=500 [mm], Web Thickness, t=10 [mm], Flange width (incl. web), bf=200 [mm], Flange thickness, tf=15 [mm], Angle Between Profile & Plate=90 [Degrees], FlipY=True, NeglectIlyz=True
10	Okvirne sponje Paluba 5	40	11 Paluba 4 - Paluba 5		1,00	1,00	Effective plate Width=1440 [mm], Plate Thickness, pT=7 [mm], Web Height, hw=450 [mm], Web Thickness, t=8 [mm], Flange width (incl. web), bf=200 [mm], Flange thickness, tf=15 [mm], Angle Between Profile & Plate=90 [Degrees], FlipY=True, NeglectIlyz=True
11	Podveze Paluba 5	40	11 Paluba 4 - Paluba 5		1,00	1,00	Effective plate Width=1440 [mm], Plate Thickness, pT=7 [mm], Web Height, hw=450 [mm], Web Thickness, t=8 [mm], Flange width (incl. web), bf=150 [mm], Flange thickness, tf=15 [mm], Angle Between Profile & Plate=90 [Degrees], FlipY=True, NeglectIlyz=True
12	Upore	10	11 Paluba 4 - Paluba 5		1,00	1,00	Outer Diameter=139.7 [mm], Thickness=8 [mm]
13	Rebra vanjske stijene salona (Paluba 4)	40	1 VL-NS Mild Steel		1,00	1,00	Effective plate Width=500 [mm], Plate Thickness, pT=7 [mm], Web Height, hw=150 [mm], Web Thickness, t=12 [mm], Flange width (incl. web), bf=225 [mm], Flange thickness, tf=15 [mm], Angle Between Profile & Plate=90 [Degrees], FlipY=True, NeglectIlyz=True
15	RolledAngles 1000 x 1500 x 7 x 7	99	11 Paluba 4 - Paluba 5		1,00	1,00	Effective plate Width=0 [mm], Plate Thickness=0 [mm], Stiffener Height, h=1000 [mm], Thickness of web, t=7 [mm], Flange width (incl. web t.), w=1500 [mm], Flange (average) Thickness=7 [mm], Radius of flange nose, r1=0 [mm], Radius betw.web && flange, r3=0 [mm], Angle of flange neck=0 [Degrees], Angle between Plate and web=90 [Degrees], NeglectIlyz=True
16	Spoj vanjske oplate i palube 4	99	9 Gl.paluba - Paluba 4		1,00	1,00	Effective plate Width=0 [mm], Plate Thickness=0 [mm], Stiffener Height, h=300 [mm], Thickness of web, t=8.5 [mm], Flange width (incl. web t.), w=300 [mm], Flange (average) Thickness=7 [mm], Radius of flange nose, r1=0 [mm], Radius betw.web && flange, r3=0 [mm], Angle of flange neck=0 [Degrees], Angle between Plate and web=90 [Degrees], NeglectIlyz=True
17	Spoj uzdužne stijene salona i palube 4	99	9 Gl.paluba - Paluba 4		1,00	1,00	Effective plate Width=0 [mm], Plate Thickness=0 [mm], Stiffener Height, h=300 [mm], Thickness of web, t=8.5 [mm], Flange width (incl. web t.), w=300 [mm], Flange (average) Thickness=7 [mm], Radius of flange nose, r1=0 [mm], Radius betw.web && flange, r3=0 [mm], Angle of flange neck=0 [Degrees], Angle between Plate and web=90 [Degrees], NeglectIlyz=True

DODATAK D

Proračun i provjera strukturnih elemenata primjenom DNV 3D-Beam programskog alata

Okvir boka garažnog prostora i nadgrađe

Profiles

Profile	Profile Name	Type	Material	Ignore S. C.	Shear factor fy	Shear factor fz	Profile parameters
18	Simulator mase kormilarnice	40	8 Kormilarnica		1,00	1,00	Effective plate Width=1000 [mm], Plate Thickness, pT=12 [mm], Web Height, hw=600 [mm], Web Thickness, t=12 [mm], Flange width (incl. web), bf=250 [mm], Flange thickness, tf=22 [mm], Angle Between Profile & Plate=90 [Degrees], FlipY=True, NeglectIyz=True
20	Simulator mase protuljnjog tanka	40	7 Protuljnjni tank		1,00	1,00	Effective plate Width=600 [mm], Plate Thickness, pT=8 [mm], Web Height, hw=300 [mm], Web Thickness, t=10 [mm], Flange width (incl. web), bf=150 [mm], Flange thickness, tf=10 [mm], Angle Between Profile & Plate=90 [Degrees], FlipY=True, NeglectIyz=True
21	Čeona pregrada salona	61	9 Gl.paluba - Paluba 4		1,00	1,00	Effective plate Width=0 [mm], Plate Thickness=0 [mm], Flatbar Height=1500 [mm], Flatbar Width=7 [mm], Angle between Plate and profile=90 [Degrees], FlipY=True, NeglectIyz=True
22	Simulator mase protuljnjog tanka 2	40	11 Paluba 4 - Paluba 5		1,00	1,00	Effective plate Width=600 [mm], Plate Thickness, pT=8 [mm], Web Height, hw=300 [mm], Web Thickness, t=10 [mm], Flange width (incl. web), bf=150 [mm], Flange thickness, tf=10 [mm], Angle Between Profile & Plate=90 [Degrees], FlipY=True, NeglectIyz=True
23	Rebra u salonu unutarnja	40	9 Gl.paluba - Paluba 4		1,00	1,00	Effective plate Width=494.7 [mm], Plate Thickness, pT=7 [mm], Web Height, hw=125 [mm], Web Thickness, t=12 [mm], Flange width (incl. web), bf=200 [mm], Flange thickness, tf=15 [mm], Angle Between Profile & Plate=90 [Degrees], FlipY=True, FlipZ=True, NeglectIyz=True
24	Rebra oplate u garaži Rebro16	40	3 VL-36 Steel		1,00	1,00	Effective plate Width=600 [mm], Plate Thickness, pT=16 [mm], Web Height, hw=550 [mm], Web Thickness, t=20 [mm], Flange width (incl. web), bf=400 [mm], Flange thickness, tf=30 [mm], Angle Between Profile & Plate=90 [Degrees], FlipY=True, FlipZ=True, NeglectIyz=True
26	Paluba3	61	1 VL-NS Mild Steel		1,00	1,00	Effective plate Width=0 [mm], Plate Thickness=0 [mm], Flatbar Height=1500 [mm], Flatbar Width=7 [mm], Angle between Plate and profile=90 [Degrees], NeglectIyz=True

Profile properties

Profile	Axial			Local x-z plane				Local x-y plane				Shear Centre	
	Ax [mm ²]	Wx [mm ³]	Ix [mm ⁴]	Az [mm ²]	Wy _t [mm ³]	Wy _b [mm ³]	Iy [mm ⁴]	Ay [mm ²]	Wz ₊ [mm ³]	Wz ₋ [mm ³]	Iz [mm ⁴]	ey [mm]	ez [mm]
2	53300	115307	7,4949e+05	13606	48124505	48118653	5,3259e+10	25998	19495159	19495159	2,9243e+10	0	0,08359
4	57200	123757	8,0442e+05	17095	63066273	63059124	8,8713e+10	25998	19495169	19495169	2,9243e+10	-1,516e-14	0,1461
5	17733	52899	5,0255e+05	4484	4693487	2380168	8,2359e+08	15073	2272515	2272515	1,6362e+09	0	166,1
6	11055	60760	5,7722e+05	2665	1395748	1196290	1,9808e+08	9192	493076	493076	1,4792e+08	0	112,3
7	8385	18123	1,7217e+05	1775	445398	880342	6,1075e+07	7120	579099	579099	2,0848e+08	0	-59,9
8	6285	21382	2,0313e+05	1249	394159	294729	2,4705e+07	5342	237359	237359	5,3406e+07	0	48,91
9	19348	51020	4,8469e+05	4386	5551533	2076276	7,8805e+08	16445	3520700	3520700	3,1686e+09	0	136,9
10	15632	49741	3,7306e+05	3202	4094012	1693250	5,6478e+08	13287	2259747	2259747	1,627e+09	0	131,7
11	14907	42967	3,2225e+05	3129	3963068	1384652	4,8382e+08	12671	2252030	2252030	1,6215e+09	0	117,4
12	3103	193957	1,3499e+07	1555	96978	96978	6,7497e+06	1555	96978	96978	6,7497e+06	0	0
13	8236	28131	3,2351e+05	1783	545649	516311	4,5497e+07	5805	325598	325598	8,14e+07	0	52,88
15	16205	35106	2,2819e+05	4727	7418305	1883737	1,5023e+09	7279	3810826	8824295	3,9909e+09	-449	199,3
16	4295	9730	77842	1774	478659	190037	4,0809e+07	1599	162024	530551	3,7174e+07	-66,07	82,01
17	4295	9730	77842	1774	478659	190037	4,0809e+07	1599	162024	530551	3,7174e+07	-66,07	82,01
18	23770	131930	1,5172e+06	6570	7094792	4152568	1,6594e+09	20205	1972473	1972473	9,8624e+08	0	210,5
20	8775	21871	2,0778e+05	2636	1317857	640694	1,3688e+08	6429	458889	458889	1,3767e+08	0	93,93
21	9750	21121	1,3729e+05	6504	2437500	2437500	1,8281e+09	6500	10562	10563	34328	0	-0,125
22	8775	21871	2,0778e+05	2636	1317857	640694	1,3688e+08	6429	458889	458889	1,3767e+08	0	93,93
23	7552	24778	2,8494e+05	1514	443271	383570	3,0125e+07	5827	303975	303975	7,5188e+07	0	47,14
24	31820	260569	5,0811e+06	10383	6304406	7101123	1,9887e+09	15259	1453614	1453614	4,3608e+08	0	101,4
26	9750	21121	1,3729e+05	6504	2437500	2437500	1,8281e+09	6500	10562	10563	34328	0	0,125

DODATAK D

Proračun i provjera strukturnih elemenata primjenom DNV 3D-Beam programskog alata

Okvir boka garažnog prostora i nadgrađe

Materials

Material	Material Name	E [N/mm ²]	Density [kg/m ³]	Poisson	Thermal Coefficient [mm/mm/C]	Yield Stress [N/mm ²]	Ultimate Strength [N/mm ²]
9	Gl.paluba - Paluba 4	210000	7711,0	0,30	1,26e-05	235	400
10	Paluba 3 (AH 36)	210000	7711,0	0,30	1,26e-05	355	490
11	Paluba 4 - Paluba 5	210000	17983,5	0,30	1,26e-05	235	400
1	VL-NS Mild Steel	210000	7800,0	0,30	1,26e-05	235	400
8	Kormilarnica	210000	5529,8	0,30	1,26e-05	235	400
7	Protuljiljni tank	210000	57944,7	0,30	1,26e-05	235	400
3	VL-36 Steel	210000	7800,0	0,30	1,26e-05	355	490

Abbreviations

Profiles:

Profile: Profile identification number

Profile Name: User's profile identification

Type: Profile type

Material: Material identification

Ignore S.C.: If ticked "X", then the program ignores the possible shear centre offset for the profile.

Shear factors f_y , f_z : The shear factor may be < 1.0 for beams with large cut-outs. The factors affect the beam stiffness but not the computed shear stress.

Profile parameters: Input parameters defining the profile.

Profile properties:

Profile: Profile identification number

Ax: Axial area (total profile area)

Wx: Torsion section modulus

Ix: Torsional moment of inertia

Az: Shear area in local z-direction ($I_y t_p / S_y$)

Wy_t: Section modulus about local y-axis at top of profile

Wy_b: Section modulus about local y-axis at bottom of profile

Iy: Moment of inertia about local y-axis

Ay: Shear area in local y-direction ($I_z t_p / S_z$)

Wz₊: Section modulus about local z-axis on positive y-side of profile

Wz₋: Section modulus about local z-axis on negative y-side of profile

Iz: Moment of inertia about local z-axis

Note: $Wz_t = Wz_b = Wz_{min}$ for all profile types except I - types

e_y: Shear centre distance from vertical neutral axis

e_z: Shear centre distance from horizontal neutral axis

f_y: Shear factor in local y-direction

f_z: Shear factor in local z-direction

Note: The shear factor is used for shear stiffness of beam, but not for calculation of shear stress

Where:

S_y, S_z: 1st area moment about y- and z- axis respectively

t_p: value for profile thickness depending on profile type

Materials:

Material: Material identification

Material Name: User's material identification

E: Young's Modulus

Density: Density

Poisson: Poisson's ratio for transverse contraction

Thermal Coefficient: Coefficient of thermal expansion

Yield Stress: Nominal yield stress

Ultimate Strength: Nominal ultimate tensile strength

DODATAK D

Proračun i provjera strukturnih elemenata primjenom DNV 3D-Beam programskog alata

Okvir boka garažnog prostora i nadgrađe

DODATAK D

Proračun i provjera strukturnih elemenata primjenom DNV 3D-Beam programskog alata

Okvir boka garažnog prostora i nadgrađe

Load case No 5 LC1+LC2+LC3+LC4 - Combination : LC1 Poprečno akceleracijsko polje (1), LC2 Palubna opterećenja (1), LC3 Opterećenje od vjetra (1), LC4 Gravitacija (1)

Beam Loads in local coordinate system, sorted by Beam in Ascending order

Beam No	Distributed Loads						Temperature Loads		
	Px1 [N/mm]	Py1 [N/mm]	Pz1 [N/mm]	Px2 [N/mm]	Py2 [N/mm]	Pz2 [N/mm]	Gy [C/mm]	Gz [C/mm]	Temperature [C]
1	-0,4943	0	-0,319	-0,4943	0	-0,319			
2	0,4093	0	-5,634	0,4093	0	-5,634			
3	0,4943	0	0,319	0,4943	0	0,319			
4	-0,4943	0	0,319	-0,4943	0	0,319			
5	-0,4093	0	-5,634	-0,4093	0	-5,634			
6	0,4943	0	-0,9778	0,4943	0	-0,9778			
7	0,8655	0	-11,34	0,8655	0	-11,34			
8	0,8655	0	-11,34	0,8655	0	-11,34			
9	-0,4943	0	-0,319	-0,4943	0	-0,319			
10	0,4093	0	-5,634	0,4093	0	-5,634			
11	0,4943	0	0,319	0,4943	0	0,319			
12	-0,4943	0	0,319	-0,4943	0	0,319			
13	0,8655	0	-16,34	0,8655	0	-16,34			
14	0,4943	0	-0,9778	0,4943	0	-0,9778			
15	-0,4093	0	-5,634	-0,4093	0	-5,634			
16	0,8655	0	-11,34	0,8655	0	-11,34			
17	0,8655	0	-11,34	0,8655	0	-11,34			
18	-0,4943	0	-0,319	-0,4943	0	-0,319			
19	0,4093	0	-5,634	0,4093	0	-5,634			
20	0,4943	0	0,319	0,4943	0	0,319			
21	-0,4943	0	0,319	-0,4943	0	0,319			
22	0,8655	0	-16,34	0,8655	0	-16,34			
23	0,4943	0	-0,9778	0,4943	0	-0,9778			
24	-0,4093	0	-5,634	-0,4093	0	-5,634			
25	0,8655	0	-11,34	0,8655	0	-11,34			
26	0,8655	0	-11,34	0,8655	0	-11,34			
27	-0,4943	0	-0,319	-0,4943	0	-0,319			
28	0,4093	0	-5,634	0,4093	0	-5,634			
29	0,4943	0	0,319	0,4943	0	0,319			
30	-0,4943	0	0,319	-0,4943	0	0,319			
31	0,8655	0	-16,34	0,8655	0	-16,34			
32	0,4943	0	-0,9778	0,4943	0	-0,9778			
33	-0,4093	0	-5,634	-0,4093	0	-5,634			
34	2,602	0	-14,03	2,602	0	-14,03			
35	2,602	0	-14,03	2,602	0	-14,03			
36	-0,4943	0	-0,319	-0,4943	0	-0,319			
37	0,4093	0	-5,634	0,4093	0	-5,634			
38	0,4943	0	0,319	0,4943	0	0,319			
39	-0,4943	0	0,319	-0,4943	0	0,319			
40	2,602	0	-19,03	2,602	0	-19,03			
41	0,4943	0	-0,9778	0,4943	0	-0,9778			
42	-0,4093	0	-5,634	-0,4093	0	-5,634			
43	-0,4943	0	-0,319	-0,4943	0	-0,319			
44	0,4093	0	-5,634	0,4093	0	-5,634			
45	-0,4943	0	-0,319	-0,4943	0	-0,319			
46	0,4093	0	-5,634	0,4093	0	-5,634			
47	-0,4943	0	-0,319	-0,4943	0	-0,319			

DODATAK D

Proračun i provjera strukturnih elemenata primjenom DNV 3D-Beam programskog alata

Okvir boka garažnog prostora i nadgrađe

Load case No 5 LC1+LC2+LC3+LC4 - Combination : LC1 Poprečno akceleracijsko polje (1), LC2 Palubna opterećenja (1), LC3 Opterećenje od vjetra (1), LC4 Gravitacija (1)

Beam Loads in local coordinate system, sorted by Beam in Ascending order

Beam No	Distributed Loads						Temperature Loads		
	Px1 [N/mm]	Py1 [N/mm]	Pz1 [N/mm]	Px2 [N/mm]	Py2 [N/mm]	Pz2 [N/mm]	Gy [C/mm]	Gz [C/mm]	Temperature [C]
48	0,4093	0	-5,634	0,4093	0	-5,634			
49	-0,4943	0	-0,319	-0,4943	0	-0,319			
50	0,4093	0	-5,634	0,4093	0	-5,634			
51	-0,4943	0	0,319	-0,4943	0	0,319			
52	-0,4093	0	-5,634	-0,4093	0	-5,634			
53	-0,4943	0	0,319	-0,4943	0	0,319			
54	-0,4093	0	-5,634	-0,4093	0	-5,634			
55	-0,4943	0	0,319	-0,4943	0	0,319			
56	-0,4093	0	-5,634	-0,4093	0	-5,634			
57	-0,4943	0	0,319	-0,4943	0	0,319			
58	-0,4093	0	-5,634	-0,4093	0	-5,634			
59	-0,8362	0	-1,198	-0,8362	0	-1,198			
60	-0,8362	0	-1,198	-0,8362	0	-1,198			
61	-0,8362	0	-1,198	-0,8362	0	-1,198			
62	-0,8362	0	-1,198	-0,8362	0	-1,198			
63	-0,8362	0	-1,198	-0,8362	0	-1,198			
64	-0,8362	0	-1,198	-0,8362	0	-1,198			
65	-0,8362	0	-1,198	-0,8362	0	-1,198			
66	-0,8362	0	-1,198	-0,8362	0	-1,198			
67	-0,8362	0	-1,198	-0,8362	0	-1,198			
68	-0,8362	0	0,5396	-0,8362	0	0,5396			
69	-0,8362	0	0,5396	-0,8362	0	0,5396			
70	-0,8362	0	0,5396	-0,8362	0	0,5396			
71	-0,8362	0	0,5396	-0,8362	0	0,5396			
72	-0,8362	0	0,5396	-0,8362	0	0,5396			
73	-0,8362	0	0,5396	-0,8362	0	0,5396			
74	-0,8362	0	0,5396	-0,8362	0	0,5396			
75	-0,8362	0	0,5396	-0,8362	0	0,5396			
76	-0,8362	0	0,5396	-0,8362	0	0,5396			
77	0	0,9444	-1,464	0	0,9444	-1,464			
78	0,8655	0	-11,34	0,8655	0	-11,34			
79	0	0,9444	-1,464	0	0,9444	-1,464			
80	0,8655	0	-11,34	0,8655	0	-11,34			
81	0	0,9444	-1,464	0	0,9444	-1,464			
82	0,8655	0	-11,34	0,8655	0	-11,34			
83	0	0,9444	-1,464	0	0,9444	-1,464			
84	2,602	0	-14,03	2,602	0	-14,03			
85	0	0,9444	-1,464	0	0,9444	-1,464			
86	0,8655	0	-11,34	0,8655	0	-11,34			
87	0	0,9444	-1,464	0	0,9444	-1,464			
88	0,8655	0	-11,34	0,8655	0	-11,34			
89	0	0,9444	-1,464	0	0,9444	-1,464			
90	0,8655	0	-11,34	0,8655	0	-11,34			
91	0	0,9444	-1,464	0	0,9444	-1,464			
92	2,602	0	-14,03	2,602	0	-14,03			
93	0	0,9444	-1,464	0	0,9444	-1,464			
94	0,8655	0	-11,34	0,8655	0	-11,34			

DODATAK D

Proračun i provjera strukturnih elemenata primjenom DNV 3D-Beam programskog alata

Okvir boka garažnog prostora i nadgrađe

Load case No 5 LC1+LC2+LC3+LC4 - Combination : LC1 Poprečno akceleracijsko polje (1), LC2 Palubna opterećenja (1), LC3 Opterećenje od vjetra (1), LC4 Gravitacija (1)

Beam Loads in local coordinate system, sorted by Beam in Ascending order

Beam No	Distributed Loads						Temperature Loads		
	Px1 [N/mm]	Py1 [N/mm]	Pz1 [N/mm]	Px2 [N/mm]	Py2 [N/mm]	Pz2 [N/mm]	Gy [C/mm]	Gz [C/mm]	Temperature [C]
95	0	0,9444	-1,464	0	0,9444	-1,464			
96	0,8655	0	-11,34	0,8655	0	-11,34			
97	0	0,9444	-1,464	0	0,9444	-1,464			
98	0,8655	0	-11,34	0,8655	0	-11,34			
99	0	0,9444	-1,464	0	0,9444	-1,464			
100	2,602	0	-14,03	2,602	0	-14,03			
101	0,8655	0	-16,34	0,8655	0	-16,34			
102	0,8655	0	-16,34	0,8655	0	-16,34			
103	0,8655	0	-11,34	0,8655	0	-11,34			
104	0,8655	0	-11,34	0,8655	0	-11,34			
105	0,5474	0,3532	0	0,5474	0,3532	0			
106	-1,779	0	-17,76	-1,779	0	-17,76			
107	-1,779	0	-17,76	-1,779	0	-17,76			
108	0,5481	0	0,3537	0,5481	0	0,3537			
109	0,7592	0	0,4899	0,7592	0	0,4899			
110	0,7592	0	-1,807	0,7592	0	-1,807			
111	0,7592	0	-1,807	0,7592	0	-1,807			
112	0	1,697	-2,63	0	1,697	-2,63			
113	0	1,697	-2,63	0	1,697	-2,63			
114	-1,779	0	-17,76	-1,779	0	-17,76			
115	0	1,697	-2,63	0	1,697	-2,63			
116	-1,779	0	-17,76	-1,779	0	-17,76			
117	0	1,697	-2,63	0	1,697	-2,63			
118	-1,779	0	-17,76	-1,779	0	-17,76			
119	0	1,697	-2,63	0	1,697	-2,63			
120	0	1,697	-2,63	0	1,697	-2,63			
121	0	1,697	-2,63	0	1,697	-2,63			
122	-1,779	0	-17,76	-1,779	0	-17,76			
123	0	1,697	-2,63	0	1,697	-2,63			
124	-1,779	0	-17,76	-1,779	0	-17,76			
125	0	1,697	-2,63	0	1,697	-2,63			
126	0	1,697	-2,63	0	1,697	-2,63			
127	-1,779	0	-17,76	-1,779	0	-17,76			
128	0	1,697	-2,63	0	1,697	-2,63			
129	-0,5474	0,3532	0	-0,5474	0,3532	0			
130	0,5481	0	-1,671	0,5481	0	-1,671			
131	2,602	0	-14,03	2,602	0	-14,03			
132	0,7592	0	-1,807	0,7592	0	-1,807			
133	0,8655	0	-11,34	0,8655	0	-11,34			
134	0,7592	0	-1,807	0,7592	0	-1,807			
135	0,5481	0	0,3537	0,5481	0	0,3537			
136	2,602	0	-19,03	2,602	0	-19,03			
137	0,7592	0	0,4899	0,7592	0	0,4899			
138	0,8655	0	-16,34	0,8655	0	-16,34			
139	-1,779	0	-17,76	-1,779	0	-17,76			
140	0,7592	0	0,4899	0,7592	0	0,4899			
141	-0,5474	0,3532	0	-0,5474	0,3532	0			

DODATAK D

Proračun i provjera strukturnih elemenata primjenom DNV 3D-Beam programskog alata

Okvir boka garažnog prostora i nadgrađe

Load case No 5 LC1+LC2+LC3+LC4 - Combination : LC1 Poprečno akceleracijsko polje (1), LC2 Palubna opterećenja (1), LC3 Opterećenje od vjetra (1), LC4 Gravitacija (1)

Beam Loads in local coordinate system, sorted by Beam in Ascending order

Beam No	Distributed Loads						Temperature Loads		
	Px1 [N/mm]	Py1 [N/mm]	Pz1 [N/mm]	Px2 [N/mm]	Py2 [N/mm]	Pz2 [N/mm]	Gy [C/mm]	Gz [C/mm]	Temperature [C]
142	-1,779	0	-17,76	-1,779	0	-17,76			
143	-1,779	0	-17,76	-1,779	0	-17,76			
144	-1,779	0	-2,758	-1,779	0	-2,758			
145	-1,779	0	-17,76	-1,779	0	-17,76			
146	-1,779	0	-17,76	-1,779	0	-17,76			
147	-1,779	0	-17,76	-1,779	0	-17,76			
148	-1,779	0	-17,76	-1,779	0	-17,76			
149	-1,779	0	-2,758	-1,779	0	-2,758			
150	-1,779	0	-17,76	-1,779	0	-17,76			
151	-1,779	0	-17,76	-1,779	0	-17,76			
152	-1,779	0	-17,76	-1,779	0	-17,76			
153	0	1,075	-1,667	0	1,075	-1,667			
154	0	1,075	-1,667	0	1,075	-1,667			
155	0	1,075	-1,667	0	1,075	-1,667			
156	0	1,075	-1,667	0	1,075	-1,667			
157	0	1,075	-1,667	0	1,075	-1,667			
158	0	1,075	-1,667	0	1,075	-1,667			
159	0	1,075	-1,667	0	1,075	-1,667			
160	0	1,075	-1,667	0	1,075	-1,667			
161	0	2,792	-4,327	0	2,792	-4,327			
162	-0,4943	0	0,319	-0,4943	0	0,319			
163	-0,4943	0	0,319	-0,4943	0	0,319			
164	0	2,792	-4,327	0	2,792	-4,327			
165	-0,4943	0	0,319	-0,4943	0	0,319			
166	-0,4943	0	0,319	-0,4943	0	0,319			
167	0	2,792	-4,327	0	2,792	-4,327			
168	-0,4943	0	0,319	-0,4943	0	0,319			
169	-0,4943	0	0,319	-0,4943	0	0,319			
170	0	2,792	-4,327	0	2,792	-4,327			
171	-0,4943	0	0,319	-0,4943	0	0,319			
172	-0,4943	0	0,319	-0,4943	0	0,319			
173	0	2,792	-4,327	0	2,792	-4,327			
174	0	2,792	-4,327	0	2,792	-4,327			
175	0	2,792	-4,327	0	2,792	-4,327			
176	0	2,792	-4,327	0	2,792	-4,327			
177	-0,4943	0	0,319	-0,4943	0	0,319			
178	0	2,792	-4,327	0	2,792	-4,327			
179	-0,4943	0	-0,319	-0,4943	0	-0,319			
180	-0,4943	0	-0,319	-0,4943	0	-0,319			
181	0	2,792	-4,327	0	2,792	-4,327			
182	-0,4943	0	-0,319	-0,4943	0	-0,319			
183	-0,4943	0	-0,319	-0,4943	0	-0,319			
184	0	2,792	-4,327	0	2,792	-4,327			
185	-0,4943	0	-0,319	-0,4943	0	-0,319			
186	-0,4943	0	-0,319	-0,4943	0	-0,319			
187	0	2,792	-4,327	0	2,792	-4,327			
188	-0,4943	0	-0,319	-0,4943	0	-0,319			

DODATAK D

Proračun i provjera strukturnih elemenata primjenom DNV 3D-Beam programskog alata

Okvir boka garažnog prostora i nadgrađe

Load case No 5 LC1+LC2+LC3+LC4 - Combination : LC1 Poprečno akceleracijsko polje (1), LC2 Palubna opterećenja (1), LC3 Opterećenje od vjetra (1), LC4 Gravitacija (1)

Beam Loads in local coordinate system, sorted by Beam in Ascending order

Beam No	Distributed Loads						Temperature Loads		
	Px1 [N/mm]	Py1 [N/mm]	Pz1 [N/mm]	Px2 [N/mm]	Py2 [N/mm]	Pz2 [N/mm]	Gy [C/mm]	Gz [C/mm]	Temperature [C]
189	-0,4943	0	-0,319	-0,4943	0	-0,319			
190	0	2,792	-4,327	0	2,792	-4,327			
191	0	2,792	-4,327	0	2,792	-4,327			
192	0	2,792	-4,327	0	2,792	-4,327			
193	0	2,792	-4,327	0	2,792	-4,327			
194	-0,4943	0	-0,319	-0,4943	0	-0,319			
195	0	0,2096	-0,3249	0	0,2096	-0,3249			
196	0	0,2096	-0,3249	0	0,2096	-0,3249			
197	0	0,2096	-0,3249	0	0,2096	-0,3249			
198	0	0,2096	-0,3249	0	0,2096	-0,3249			
199	0	0,2096	-0,3249	0	0,2096	-0,3249			
200	0	0,2096	-0,3249	0	0,2096	-0,3249			
201	0	0,2096	-0,3249	0	0,2096	-0,3249			
202	0	0,2096	-0,3249	0	0,2096	-0,3249			
203	0	0,2096	-0,3249	0	0,2096	-0,3249			
204	0	0,2096	-0,3249	0	0,2096	-0,3249			
205	0	0,2096	-0,3249	0	0,2096	-0,3249			
206	0	0,2096	-0,3249	0	0,2096	-0,3249			
207	0	0,2096	-0,3249	0	0,2096	-0,3249			
208	0	0,2096	-0,3249	0	0,2096	-0,3249			
209	0	0,2096	-0,3249	0	0,2096	-0,3249			
210	0	0,2096	-0,3249	0	0,2096	-0,3249			
211	0	0,2096	-0,3249	0	0,2096	-0,3249			
212	0	0,2096	-0,3249	0	0,2096	-0,3249			
213	0	0,2096	-0,3249	0	0,2096	-0,3249			
214	0	0,2096	-0,3249	0	0,2096	-0,3249			
215	0	0,2096	-0,3249	0	0,2096	-0,3249			
216	0	0,2096	-0,3249	0	0,2096	-0,3249			
217	0	0,2096	-0,3249	0	0,2096	-0,3249			
218	0	0,2096	-0,3249	0	0,2096	-0,3249			
219	0,4943	0	-0,9778	0,4943	0	-0,9778			
220	0	0,2096	-0,3249	0	0,2096	-0,3249			
221	0,4943	0	-0,9778	0,4943	0	-0,9778			
222	0	0,2096	-0,3249	0	0,2096	-0,3249			
223	0,4943	0	-0,9778	0,4943	0	-0,9778			
224	0	0,2096	-0,3249	0	0,2096	-0,3249			
225	0,4943	0	-0,9778	0,4943	0	-0,9778			
226	0	0,2096	-0,3249	0	0,2096	-0,3249			
227	0,4943	0	0,319	0,4943	0	0,319			
228	0	0,2096	-0,3249	0	0,2096	-0,3249			
229	0,4943	0	0,319	0,4943	0	0,319			
230	0	0,2096	-0,3249	0	0,2096	-0,3249			
231	0,4943	0	0,319	0,4943	0	0,319			
232	0	0,2096	-0,3249	0	0,2096	-0,3249			
233	0,4943	0	0,319	0,4943	0	0,319			
234	0	0,2096	-0,3249	0	0,2096	-0,3249			
235	-0,832	0	-1,289	-0,832	0	-1,289			

DODATAK D

Proračun i provjera strukturnih elemenata primjenom DNV 3D-Beam programskog alata

Okvir boka garažnog prostora i nadgrađe

Load case No 5 LC1+LC2+LC3+LC4 - Combination : LC1 Poprečno akceleracijsko polje (1), LC2 Palubna opterećenja (1), LC3 Opterećenje od vjetra (1), LC4 Gravitacija (1)

Beam Loads in local coordinate system, sorted by Beam in Ascending order

Beam No	Distributed Loads						Temperature Loads		
	Px1 [N/mm]	Py1 [N/mm]	Pz1 [N/mm]	Px2 [N/mm]	Py2 [N/mm]	Pz2 [N/mm]	Gy [C/mm]	Gz [C/mm]	Temperature [C]
236	-0,832	0	-1,289	-0,832	0	-1,289			
237	4,988	0	3,219	4,988	0	3,219			
238	0	-0,9989	-1,548	0	-0,9989	-1,548			
239	0	-3,219	-4,988	0	-3,219	-4,988			
240	4,988	0	-3,219	4,988	0	-3,219			
241	0	-0,9989	-1,548	0	-0,9989	-1,548			
242	0	-3,219	-4,988	0	-3,219	-4,988			
243	-3,219	0	-4,988	-3,219	0	-4,988			
244	-3,219	0	-4,988	-3,219	0	-4,988			
245	-3,219	0	-4,988	-3,219	0	-4,988			
246	-3,219	0	-4,988	-3,219	0	-4,988			
247	-3,219	0	-4,988	-3,219	0	-4,988			
248	-0,832	0	-1,289	-0,832	0	-1,289			
249	-3,219	0	-4,988	-3,219	0	-4,988			
250	0	-0,832	-1,289	0	-0,832	-1,289			
251	0	-3,219	-4,988	0	-3,219	-4,988			
252	0	-0,832	-1,289	0	-0,832	-1,289			
253	-3,219	0	-4,988	-3,219	0	-4,988			
254	0	-3,219	-4,988	0	-3,219	-4,988			
255	0	-0,832	-1,289	0	-0,832	-1,289			
256	0	-0,832	-1,289	0	-0,832	-1,289			
257	0	-0,832	-1,289	0	-0,832	-1,289			
258	0	-0,832	-1,289	0	-0,832	-1,289			
259	-0,832	0	-1,289	-0,832	0	-1,289			
260	-0,832	0	-1,289	-0,832	0	-1,289			
261	-0,832	0	-1,289	-0,832	0	-1,289			
262	1,289	0	0,832	1,289	0	0,832			
263	1,289	0	-1,757	1,289	0	-1,757			
264	1,289	0	-1,757	1,289	0	-1,757			
265	1,289	0	0,832	1,289	0	0,832			
266	1,289	0	0,832	1,289	0	0,832			
267	1,289	0	-1,757	1,289	0	-1,757			
268	-0,832	0	-1,289	-0,832	0	-1,289			
269	-0,832	0	-1,289	-0,832	0	-1,289			
270	-0,832	0	-1,289	-0,832	0	-1,289			
271	-3,219	0	-4,988	-3,219	0	-4,988			
272	-3,219	0	-4,988	-3,219	0	-4,988			
273	-3,219	0	-4,988	-3,219	0	-4,988			
274	-1,779	0	-2,758	-1,779	0	-2,758			
275	0	1,075	-1,667	0	1,075	-1,667			
276	-1,779	0	-17,76	-1,779	0	-17,76			
277	-1,779	0	-17,76	-1,779	0	-17,76			
278	-1,779	0	-17,76	-1,779	0	-17,76			
279	-1,779	0	-17,76	-1,779	0	-17,76			
280	-1,779	0	-2,758	-1,779	0	-2,758			
281	0	1,075	-1,667	0	1,075	-1,667			
282	-1,779	0	-17,76	-1,779	0	-17,76			

DODATAK D

Proračun i provjera strukturnih elemenata primjenom DNV 3D-Beam programskog alata

Okvir boka garažnog prostora i nadgrađe

Load case No 5 LC1+LC2+LC3+LC4 - Combination : LC1 Poprečno akceleracijsko polje (1), LC2 Palubna opterećenja (1), LC3 Opterećenje od vjetra (1), LC4 Gravitacija (1)

Beam Loads in local coordinate system, sorted by Beam in Ascending order

Beam No	Distributed Loads						Temperature Loads		
	Px1 [N/mm]	Py1 [N/mm]	Pz1 [N/mm]	Px2 [N/mm]	Py2 [N/mm]	Pz2 [N/mm]	Gy [C/mm]	Gz [C/mm]	Temperature [C]
283	-1,779	0	-17,76	-1,779	0	-17,76			
284	-4,988	0	-3,219	-4,988	0	-3,219			
285	-4,988	0	3,219	-4,988	0	3,219			
286	-0,8655	0	-16,34	-0,8655	0	-16,34			
287	-0,8655	0	-11,34	-0,8655	0	-11,34			
288	-0,8655	0	-11,34	-0,8655	0	-11,34			
289	-0,8655	0	-16,34	-0,8655	0	-16,34			
290	-0,8655	0	-11,34	-0,8655	0	-11,34			
291	-0,8655	0	-11,34	-0,8655	0	-11,34			
292	-0,8655	0	-11,34	-0,8655	0	-11,34			
293	-0,8655	0	-11,34	-0,8655	0	-11,34			
294	-0,8655	0	-11,34	-0,8655	0	-11,34			
295	-0,8655	0	-11,34	-0,8655	0	-11,34			
296	0,5474	0,3532	0	0,5474	0,3532	0			
297	0,8655	0	-11,34	0,8655	0	-11,34			
298	-0,5474	0,3532	0	-0,5474	0,3532	0			
299	0,8655	0	-11,34	0,8655	0	-11,34			
300	-1,779	0	-17,76	-1,779	0	-17,76			
301	-0,07715	0	-0,8743	-0,07715	0	-0,8743			
302	0,8285	0	-0,29	0,8285	0	-0,29			
303	-0,07715	0	-0,8743	-0,07715	0	-0,8743			
304	0,8285	0	-0,29	0,8285	0	-0,29			
305	0,8285	0	-0,29	0,8285	0	-0,29			
306	-0,07715	0	-0,8743	-0,07715	0	-0,8743			
307	0,8285	0	-0,29	0,8285	0	-0,29			
308	-0,07715	0	-0,8743	-0,07715	0	-0,8743			
309	-0,07715	0	-0,8743	-0,07715	0	-0,8743			
310	0,8285	0	-0,29	0,8285	0	-0,29			
311	-0,07715	0	-0,8743	-0,07715	0	-0,8743			
312	0,8285	0	-0,29	0,8285	0	-0,29			
313	0,8285	0	-0,29	0,8285	0	-0,29			
314	-0,07715	0	-0,8743	-0,07715	0	-0,8743			
315	0,8285	0	-0,29	0,8285	0	-0,29			
316	-0,07715	0	-0,8743	-0,07715	0	-0,8743			
317	-1,779	0	-17,76	-1,779	0	-17,76			
318	0,8655	0	-11,34	0,8655	0	-11,34			
319	-0,5474	0,3532	0	-0,5474	0,3532	0			
320	0,8655	0	-11,34	0,8655	0	-11,34			
321	0,5474	0,3532	0	0,5474	0,3532	0			
322	-1,779	0	-17,76	-1,779	0	-17,76			
323	-1,779	0	-17,76	-1,779	0	-17,76			
324	0	-1,075	-1,667	0	-1,075	-1,667			
325	-1,779	0	-2,758	-1,779	0	-2,758			
326	-1,779	0	-17,76	-1,779	0	-17,76			
327	-1,779	0	-17,76	-1,779	0	-17,76			
328	-1,779	0	-17,76	-1,779	0	-17,76			
329	-1,779	0	-17,76	-1,779	0	-17,76			

DODATAK D

Proračun i provjera strukturnih elemenata primjenom DNV 3D-Beam programskog alata

Okvir boka garažnog prostora i nadgrađe

Load case No 5 LC1+LC2+LC3+LC4 - Combination : LC1 Poprečno akceleracijsko polje (1), LC2 Palubna opterećenja (1), LC3 Opterećenje od vjetra (1), LC4 Gravitacija (1)

Beam Loads in local coordinate system, sorted by Beam in Ascending order

Beam No	Distributed Loads						Temperature Loads		
	Px1 [N/mm]	Py1 [N/mm]	Pz1 [N/mm]	Px2 [N/mm]	Py2 [N/mm]	Pz2 [N/mm]	Gy [C/mm]	Gz [C/mm]	Temperature [C]
330	0	-1,075	-1,667	0	-1,075	-1,667			
331	-1,779	0	-2,758	-1,779	0	-2,758			
332	1,289	0	0,832	1,289	0	0,832			
333	1,289	0	-1,757	1,289	0	-1,757			
334	1,289	0	-1,757	1,289	0	-1,757			
335	1,289	0	0,832	1,289	0	0,832			
336	-0,832	0	-1,289	-0,832	0	-1,289			
337	-0,832	0	-1,289	-0,832	0	-1,289			
338	-0,832	0	-1,289	-0,832	0	-1,289			
339	0	0,832	-1,289	0	0,832	-1,289			
340	0	0,832	-1,289	0	0,832	-1,289			
341	0	0,832	-1,289	0	0,832	-1,289			
342	0	0,832	-1,289	0	0,832	-1,289			
343	0	3,219	-4,988	0	3,219	-4,988			
344	-3,219	0	-4,988	-3,219	0	-4,988			
345	0	0,832	-1,289	0	0,832	-1,289			
346	0	3,219	-4,988	0	3,219	-4,988			
347	0	0,832	-1,289	0	0,832	-1,289			
348	-3,219	0	-4,988	-3,219	0	-4,988			
349	-0,832	0	-1,289	-0,832	0	-1,289			
350	-3,219	0	-4,988	-3,219	0	-4,988			
351	-3,219	0	-4,988	-3,219	0	-4,988			
352	-3,219	0	-4,988	-3,219	0	-4,988			
353	-3,219	0	-4,988	-3,219	0	-4,988			
354	-3,219	0	-4,988	-3,219	0	-4,988			
355	0	3,219	-4,988	0	3,219	-4,988			
356	0	0,9989	-1,548	0	0,9989	-1,548			
357	4,988	0	-3,219	4,988	0	-3,219			
358	0	3,219	-4,988	0	3,219	-4,988			
359	0	0,9989	-1,548	0	0,9989	-1,548			
360	4,988	0	3,219	4,988	0	3,219			
361	-0,832	0	-1,289	-0,832	0	-1,289			
362	-0,832	0	-1,289	-0,832	0	-1,289			
363	0	-0,2096	-0,3249	0	-0,2096	-0,3249			
364	0,4943	0	0,319	0,4943	0	0,319			
365	0	-0,2096	-0,3249	0	-0,2096	-0,3249			
366	0,4943	0	0,319	0,4943	0	0,319			
367	0	-0,2096	-0,3249	0	-0,2096	-0,3249			
368	0,4943	0	0,319	0,4943	0	0,319			
369	0	-0,2096	-0,3249	0	-0,2096	-0,3249			
370	0,4943	0	0,319	0,4943	0	0,319			
371	0	-0,2096	-0,3249	0	-0,2096	-0,3249			
372	0,4943	0	-0,9778	0,4943	0	-0,9778			
373	0	-0,2096	-0,3249	0	-0,2096	-0,3249			
374	0,4943	0	-0,9778	0,4943	0	-0,9778			
375	0	-0,2096	-0,3249	0	-0,2096	-0,3249			
376	0,4943	0	-0,9778	0,4943	0	-0,9778			

DODATAK D

Proračun i provjera strukturnih elemenata primjenom DNV 3D-Beam programskog alata

Okvir boka garažnog prostora i nadgrađe

Load case No 5 LC1+LC2+LC3+LC4 - Combination : LC1 Poprečno akceleracijsko polje (1), LC2 Palubna opterećenja (1), LC3 Opterećenje od vjetra (1), LC4 Gravitacija (1)

Beam Loads in local coordinate system, sorted by Beam in Ascending order

Beam No	Distributed Loads						Temperature Loads		
	Px1 [N/mm]	Py1 [N/mm]	Pz1 [N/mm]	Px2 [N/mm]	Py2 [N/mm]	Pz2 [N/mm]	Gy [C/mm]	Gz [C/mm]	Temperature [C]
377	0	-0,2096	-0,3249	0	-0,2096	-0,3249			
378	0,4943	0	-0,9778	0,4943	0	-0,9778			
379	0	-0,2096	-0,3249	0	-0,2096	-0,3249			
380	0	-0,2096	-0,3249	0	-0,2096	-0,3249			
381	0	-0,2096	-0,3249	0	-0,2096	-0,3249			
382	0	-0,2096	-0,3249	0	-0,2096	-0,3249			
383	0	-0,2096	-0,3249	0	-0,2096	-0,3249			
384	0	-0,2096	-0,3249	0	-0,2096	-0,3249			
385	0	-0,2096	-0,3249	0	-0,2096	-0,3249			
386	0	-0,2096	-0,3249	0	-0,2096	-0,3249			
387	0	-0,2096	-0,3249	0	-0,2096	-0,3249			
388	0	-0,2096	-0,3249	0	-0,2096	-0,3249			
389	0	-0,2096	-0,3249	0	-0,2096	-0,3249			
390	0	-0,2096	-0,3249	0	-0,2096	-0,3249			
391	0	-0,2096	-0,3249	0	-0,2096	-0,3249			
392	0	-0,2096	-0,3249	0	-0,2096	-0,3249			
393	0	-0,2096	-0,3249	0	-0,2096	-0,3249			
394	0	-0,2096	-0,3249	0	-0,2096	-0,3249			
395	0	-0,2096	-0,3249	0	-0,2096	-0,3249			
396	0	-0,2096	-0,3249	0	-0,2096	-0,3249			
397	0	-0,2096	-0,3249	0	-0,2096	-0,3249			
398	0	-0,2096	-0,3249	0	-0,2096	-0,3249			
399	0	-0,2096	-0,3249	0	-0,2096	-0,3249			
400	0	-0,2096	-0,3249	0	-0,2096	-0,3249			
401	0	-0,2096	-0,3249	0	-0,2096	-0,3249			
402	0	-0,2096	-0,3249	0	-0,2096	-0,3249			
403	0	-2,792	-4,327	0	-2,792	-4,327			
404	0	-2,792	-4,327	0	-2,792	-4,327			
405	0	-2,792	-4,327	0	-2,792	-4,327			
406	0	-2,792	-4,327	0	-2,792	-4,327			
407	-0,4943	0	-0,319	-0,4943	0	-0,319			
408	-0,4943	0	-0,319	-0,4943	0	-0,319			
409	0	-2,792	-4,327	0	-2,792	-4,327			
410	-0,4943	0	-0,319	-0,4943	0	-0,319			
411	-0,4943	0	-0,319	-0,4943	0	-0,319			
412	0	-2,792	-4,327	0	-2,792	-4,327			
413	-0,4943	0	-0,319	-0,4943	0	-0,319			
414	-0,4943	0	-0,319	-0,4943	0	-0,319			
415	0	-2,792	-4,327	0	-2,792	-4,327			
416	-0,4943	0	-0,319	-0,4943	0	-0,319			
417	-0,4943	0	-0,319	-0,4943	0	-0,319			
418	0	-2,792	-4,327	0	-2,792	-4,327			
419	0	-2,792	-4,327	0	-2,792	-4,327			
420	0	-2,792	-4,327	0	-2,792	-4,327			
421	0	-2,792	-4,327	0	-2,792	-4,327			
422	0	-2,792	-4,327	0	-2,792	-4,327			
423	-0,4943	0	0,319	-0,4943	0	0,319			

DODATAK D

Proračun i provjera strukturnih elemenata primjenom DNV 3D-Beam programskog alata

Okvir boka garažnog prostora i nadgrađe

Load case No 5 LC1+LC2+LC3+LC4 - Combination : LC1 Poprečno akceleracijsko polje (1), LC2 Palubna opterećenja (1), LC3 Opterećenje od vjetra (1), LC4 Gravitacija (1)

Beam Loads in local coordinate system, sorted by Beam in Ascending order

Beam No	Distributed Loads						Temperature Loads		
	Px1 [N/mm]	Py1 [N/mm]	Pz1 [N/mm]	Px2 [N/mm]	Py2 [N/mm]	Pz2 [N/mm]	Gy [C/mm]	Gz [C/mm]	Temperature [C]
424	-0,4943	0	0,319	-0,4943	0	0,319			
425	0	-2,792	-4,327	0	-2,792	-4,327			
426	-0,4943	0	0,319	-0,4943	0	0,319			
427	-0,4943	0	0,319	-0,4943	0	0,319			
428	0	-2,792	-4,327	0	-2,792	-4,327			
429	-0,4943	0	0,319	-0,4943	0	0,319			
430	-0,4943	0	0,319	-0,4943	0	0,319			
431	0	-2,792	-4,327	0	-2,792	-4,327			
432	-0,4943	0	0,319	-0,4943	0	0,319			
433	-0,4943	0	0,319	-0,4943	0	0,319			
434	0	-2,792	-4,327	0	-2,792	-4,327			
435	0	-1,075	-1,667	0	-1,075	-1,667			
436	0	-1,075	-1,667	0	-1,075	-1,667			
437	0	-1,075	-1,667	0	-1,075	-1,667			
438	0	-1,075	-1,667	0	-1,075	-1,667			
439	0	-1,075	-1,667	0	-1,075	-1,667			
440	0	-1,075	-1,667	0	-1,075	-1,667			
441	0	-1,075	-1,667	0	-1,075	-1,667			
442	0	-1,075	-1,667	0	-1,075	-1,667			
443	-1,779	0	-17,76	-1,779	0	-17,76			
444	-1,779	0	-17,76	-1,779	0	-17,76			
445	-1,779	0	-17,76	-1,779	0	-17,76			
446	-1,779	0	-17,76	-1,779	0	-17,76			
447	0,8655	0	-16,34	0,8655	0	-16,34			
448	0,7592	0	0,4899	0,7592	0	0,4899			
449	2,602	0	-19,03	2,602	0	-19,03			
450	0,5481	0	0,3537	0,5481	0	0,3537			
451	0,8655	0	-11,34	0,8655	0	-11,34			
452	0,7592	0	-1,807	0,7592	0	-1,807			
453	2,602	0	-14,03	2,602	0	-14,03			
454	0,5481	0	-1,671	0,5481	0	-1,671			
455	0	-1,697	-2,63	0	-1,697	-2,63			
456	-1,779	0	-17,76	-1,779	0	-17,76			
457	0	-1,697	-2,63	0	-1,697	-2,63			
458	0	-1,697	-2,63	0	-1,697	-2,63			
459	-1,779	0	-17,76	-1,779	0	-17,76			
460	0	-1,697	-2,63	0	-1,697	-2,63			
461	-1,779	0	-17,76	-1,779	0	-17,76			
462	0	-1,697	-2,63	0	-1,697	-2,63			
463	0	-1,697	-2,63	0	-1,697	-2,63			
464	0	-1,697	-2,63	0	-1,697	-2,63			
465	-1,779	0	-17,76	-1,779	0	-17,76			
466	0	-1,697	-2,63	0	-1,697	-2,63			
467	-1,779	0	-17,76	-1,779	0	-17,76			
468	0	-1,697	-2,63	0	-1,697	-2,63			
469	-1,779	0	-17,76	-1,779	0	-17,76			
470	0	-1,697	-2,63	0	-1,697	-2,63			

DODATAK D

Proračun i provjera strukturnih elemenata primjenom DNV 3D-Beam programskog alata

Okvir boka garažnog prostora i nadgrađe

Load case No 5 LC1+LC2+LC3+LC4 - Combination : LC1 Poprečno akceleracijsko polje (1), LC2 Palubna opterećenja (1), LC3 Opterećenje od vjetra (1), LC4 Gravitacija (1)

Beam Loads in local coordinate system, sorted by Beam in Ascending order

Beam No	Distributed Loads						Temperature Loads		
	Px1 [N/mm]	Py1 [N/mm]	Pz1 [N/mm]	Px2 [N/mm]	Py2 [N/mm]	Pz2 [N/mm]	Gy [C/mm]	Gz [C/mm]	Temperature [C]
471	0	-1,697	-2,63	0	-1,697	-2,63			
472	0,7592	0	-1,807	0,7592	0	-1,807			
473	0,7592	0	-1,807	0,7592	0	-1,807			
474	0,7592	0	0,4899	0,7592	0	0,4899			
475	0,5481	0	0,3537	0,5481	0	0,3537			
476	-1,779	0	-17,76	-1,779	0	-17,76			
477	-1,779	0	-17,76	-1,779	0	-17,76			
478	0,8655	0	-11,34	0,8655	0	-11,34			
479	0,8655	0	-11,34	0,8655	0	-11,34			
480	0,8655	0	-16,34	0,8655	0	-16,34			
481	0,8655	0	-16,34	0,8655	0	-16,34			
482	2,602	0	-14,03	2,602	0	-14,03			
483	0	-0,9444	-1,464	0	-0,9444	-1,464			
484	0,8655	0	-11,34	0,8655	0	-11,34			
485	0	-0,9444	-1,464	0	-0,9444	-1,464			
486	0,8655	0	-11,34	0,8655	0	-11,34			
487	0	-0,9444	-1,464	0	-0,9444	-1,464			
488	0,8655	0	-11,34	0,8655	0	-11,34			
489	0	-0,9444	-1,464	0	-0,9444	-1,464			
490	2,602	0	-14,03	2,602	0	-14,03			
491	0	-0,9444	-1,464	0	-0,9444	-1,464			
492	0,8655	0	-11,34	0,8655	0	-11,34			
493	0	-0,9444	-1,464	0	-0,9444	-1,464			
494	0,8655	0	-11,34	0,8655	0	-11,34			
495	0	-0,9444	-1,464	0	-0,9444	-1,464			
496	0,8655	0	-11,34	0,8655	0	-11,34			
497	0	-0,9444	-1,464	0	-0,9444	-1,464			
498	2,602	0	-14,03	2,602	0	-14,03			
499	0	-0,9444	-1,464	0	-0,9444	-1,464			
500	0,8655	0	-11,34	0,8655	0	-11,34			
501	0	-0,9444	-1,464	0	-0,9444	-1,464			
502	0,8655	0	-11,34	0,8655	0	-11,34			
503	0	-0,9444	-1,464	0	-0,9444	-1,464			
504	0,8655	0	-11,34	0,8655	0	-11,34			
505	0	-0,9444	-1,464	0	-0,9444	-1,464			
506	-0,8362	0	0,5396	-0,8362	0	0,5396			
507	-0,8362	0	0,5396	-0,8362	0	0,5396			
508	-0,8362	0	0,5396	-0,8362	0	0,5396			
509	-0,8362	0	0,5396	-0,8362	0	0,5396			
510	-0,8362	0	0,5396	-0,8362	0	0,5396			
511	-0,8362	0	0,5396	-0,8362	0	0,5396			
512	-0,8362	0	0,5396	-0,8362	0	0,5396			
513	-0,8362	0	0,5396	-0,8362	0	0,5396			
514	-0,8362	0	-1,198	-0,8362	0	-1,198			
515	-0,8362	0	-1,198	-0,8362	0	-1,198			
516	-0,8362	0	-1,198	-0,8362	0	-1,198			
517	-0,8362	0	-1,198	-0,8362	0	-1,198			

DODATAK D

Proračun i provjera strukturnih elemenata primjenom DNV 3D-Beam programskog alata

Okvir boka garažnog prostora i nadgrađe

Load case No 5 LC1+LC2+LC3+LC4 - Combination : LC1 Poprečno akceleracijsko polje (1), LC2 Palubna opterećenja (1), LC3 Opterećenje od vjetrova (1), LC4 Gravitacija (1)

Beam Loads in local coordinate system, sorted by Beam in Ascending order

Beam No	Distributed Loads						Temperature Loads		
	Px1 [N/mm]	Py1 [N/mm]	Pz1 [N/mm]	Px2 [N/mm]	Py2 [N/mm]	Pz2 [N/mm]	Gy [C/mm]	Gz [C/mm]	Temperature [C]
518	-0,8362	0	-1,198	-0,8362	0	-1,198			
519	-0,8362	0	-1,198	-0,8362	0	-1,198			
520	-0,8362	0	-1,198	-0,8362	0	-1,198			
521	-0,8362	0	-1,198	-0,8362	0	-1,198			
522	-0,4093	0	-5,634	-0,4093	0	-5,634			
523	-0,4943	0	0,319	-0,4943	0	0,319			
524	-0,4093	0	-5,634	-0,4093	0	-5,634			
525	-0,4943	0	0,319	-0,4943	0	0,319			
526	-0,4093	0	-5,634	-0,4093	0	-5,634			
527	-0,4943	0	0,319	-0,4943	0	0,319			
528	-0,4093	0	-5,634	-0,4093	0	-5,634			
529	-0,4943	0	0,319	-0,4943	0	0,319			
530	0,4093	0	-5,634	0,4093	0	-5,634			
531	-0,4943	0	-0,319	-0,4943	0	-0,319			
532	0,4093	0	-5,634	0,4093	0	-5,634			
533	-0,4943	0	-0,319	-0,4943	0	-0,319			
534	0,4093	0	-5,634	0,4093	0	-5,634			
535	-0,4943	0	-0,319	-0,4943	0	-0,319			
536	0,4093	0	-5,634	0,4093	0	-5,634			
537	-0,4943	0	-0,319	-0,4943	0	-0,319			
538	-0,4093	0	-5,634	-0,4093	0	-5,634			
539	0,4943	0	-0,9778	0,4943	0	-0,9778			
540	2,602	0	-19,03	2,602	0	-19,03			
541	-0,4943	0	0,319	-0,4943	0	0,319			
542	0,4943	0	0,319	0,4943	0	0,319			
543	0,4093	0	-5,634	0,4093	0	-5,634			
544	-0,4943	0	-0,319	-0,4943	0	-0,319			
545	2,602	0	-14,03	2,602	0	-14,03			
546	2,602	0	-14,03	2,602	0	-14,03			
547	-0,4093	0	-5,634	-0,4093	0	-5,634			
548	0,4943	0	-0,9778	0,4943	0	-0,9778			
549	0,8655	0	-16,34	0,8655	0	-16,34			
550	-0,4943	0	0,319	-0,4943	0	0,319			
551	0,4943	0	0,319	0,4943	0	0,319			
552	0,4093	0	-5,634	0,4093	0	-5,634			
553	-0,4943	0	-0,319	-0,4943	0	-0,319			
554	0,8655	0	-11,34	0,8655	0	-11,34			
555	0,8655	0	-11,34	0,8655	0	-11,34			
556	-0,4093	0	-5,634	-0,4093	0	-5,634			
557	0,4943	0	-0,9778	0,4943	0	-0,9778			
558	0,8655	0	-16,34	0,8655	0	-16,34			
559	-0,4943	0	0,319	-0,4943	0	0,319			
560	0,4943	0	0,319	0,4943	0	0,319			
561	0,4093	0	-5,634	0,4093	0	-5,634			
562	-0,4943	0	-0,319	-0,4943	0	-0,319			
563	0,8655	0	-11,34	0,8655	0	-11,34			
564	0,8655	0	-11,34	0,8655	0	-11,34			

DODATAK D

Proračun i provjera strukturnih elemenata primjenom DNV 3D-Beam programskog alata

Okvir boka garažnog prostora i nadgrađe

Load case No 5 LC1+LC2+LC3+LC4 - Combination : LC1 Poprečno akceleracijsko polje (1), LC2 Palubna opterećenja (1), LC3 Opterećenje od vjetra (1), LC4 Gravitacija (1)

Beam Loads in local coordinate system, sorted by Beam in Ascending order

Beam No	Distributed Loads						Temperature Loads		
	Px1 [N/mm]	Py1 [N/mm]	Pz1 [N/mm]	Px2 [N/mm]	Py2 [N/mm]	Pz2 [N/mm]	Gy [C/mm]	Gz [C/mm]	Temperature [C]
565	-0,4093	0	-5,634	-0,4093	0	-5,634			
566	0,4943	0	-0,9778	0,4943	0	-0,9778			
567	0,8655	0	-16,34	0,8655	0	-16,34			
568	-0,4943	0	0,319	-0,4943	0	0,319			
569	0,4943	0	0,319	0,4943	0	0,319			
570	0,4093	0	-5,634	0,4093	0	-5,634			
571	-0,4943	0	-0,319	-0,4943	0	-0,319			
572	0,8655	0	-11,34	0,8655	0	-11,34			
573	0,8655	0	-11,34	0,8655	0	-11,34			

Abbreviations

Beam No:	Beam identification number
Px1, Px2:	Load intensity in local x-direction at the start and end ends of the beam respectively
Py1, Py2:	Load intensity in local y-direction at the start and end ends of the beam respectively
Pz1, Pz2:	Load intensity in local z-direction at the start and end ends of the beam respectively
Gy, Gz:	Temperature gradients in local y- and z-directions
Temperature:	Mean temperature. NB! Any non-zero value is regarded as a temperature load

DODATAK D

Proračun i provjera strukturnih elemenata primjenom DNV 3D-Beam programskog alata

Okvir boka garažnog prostora i nadgrađe

Load case No 5 LC1+LC2+LC3+LC4 - Combination : LC1 Poprečno akceleracijsko polje (1), LC2 Palubna opterećenja (1), LC3 Opterećenje od vjetra (1), LC4 Gravitacija (1)

Beam Stresses, values, sorted by Sig-My in Descending order

Beam No.	σ_{Nx} [N/mm ²]	τ_{Qy} [N/mm ²]	τ_{Qz} [N/mm ²]	τ_{Mx} [N/mm ²]	σ_{My} [N/mm ²]	σ_{Mz} [N/mm ²]
307	71	0	51	0	298	1
310	71	0	51	0	298	1
360	10	0	77	0	203	3
350	23	0	30	0	203	6
443	15	3	47	0	202	32
152	15	3	46	0	199	32
249	12	0	23	0	199	3
150	3	2	46	0	197	38
445	3	2	45	0	194	38
271	17	0	29	0	193	9
285	10	0	66	0	190	3
351	22	0	27	0	190	17
237	9	0	64	0	188	6
247	20	1	27	0	187	14
272	10	0	24	0	186	9
137	20	1	39	0	186	42
448	25	1	35	0	175	61
2	3	0	25	0	175	0
348	9	0	20	0	173	7
140	38	0	32	0	170	14
10	3	0	24	0	169	5
570	3	0	24	0	169	6
44	5	0	24	0	168	3
536	5	0	24	0	167	4
246	19	1	25	0	164	21
194	41	1	33	0	164	18
188	20	3	32	0	162	41
76	36	0	54	0	161	3
506	36	0	54	0	161	3
203	18	3	27	0	160	24
277	1	1	36	0	160	21
108	12	1	33	0	160	47
408	28	3	32	0	159	43
109	5	1	31	0	159	49
394	18	3	26	0	158	21
46	4	0	23	0	158	6
534	4	0	23	0	158	6
474	12	1	31	0	158	35
390	17	0	26	0	157	11
19	3	0	22	0	155	3
475	10	1	32	0	154	53
561	3	0	22	0	154	4
331	13	3	32	0	154	25
411	32	6	30	0	150	81
3	29	0	20	0	150	17
185	30	5	30	0	149	78
207	18	1	23	0	147	13
147	4	0	33	0	145	2
48	3	0	21	0	142	1
532	4	0	21	0	141	2

DODATAK D

Proračun i provjera strukturnih elemenata primjenom DNV 3D-Beam programskog alata

Okvir boka garažnog prostora i nadgrađe

Load case No 5 LC1+LC2+LC3+LC4 - Combination : LC1 Poprečno akceleracijsko polje (1), LC2 Palubna opterećenja (1), LC3 Opterećenje od vjetra (1), LC4 Gravitacija (1)

Beam Stresses, values, sorted by Sig-My in Descending order

Beam No.	σ_{Nx} [N/mm ²]	τ_{Qy} [N/mm ²]	τ_{Qz} [N/mm ²]	τ_{Mx} [N/mm ²]	σ_{My} [N/mm ²]	σ_{Mz} [N/mm ²]
210	11	2	22	2	136	14
569	25	0	18	0	134	1
28	2	0	19	0	134	8
552	2	0	19	0	134	9
578	7	0	8	0	133	0
574	7	0	8	0	132	0
11	17	0	17	0	130	2
243	11	0	26	0	130	4
240	9	1	35	0	129	9
151	8	1	21	0	128	29
444	8	1	21	0	128	30
452	19	1	27	0	126	36
473	5	1	25	0	125	48
110	11	1	25	0	125	35
274	12	3	28	0	125	24
575	25	0	8	0	124	0
284	8	0	28	0	123	3
5	2	0	18	0	122	0
581	26	0	7	0	122	0
50	2	0	17	0	122	15
530	2	0	17	0	121	16
149	11	0	25	0	119	3
316	25	0	26	0	118	0
301	25	0	26	0	118	0
208	4	1	19	1	117	10
472	12	1	25	0	117	41
528	2	0	18	0	117	5
52	2	0	18	0	116	6
565	1	0	17	0	116	10
15	1	0	17	0	116	10
396	14	2	19	1	115	21
357	8	1	24	0	114	6
537	3	0	24	0	114	3
43	3	0	24	0	114	2
354	8	0	23	0	114	7
132	22	1	24	0	112	52
286	1	0	49	0	111	1
111	11	1	24	0	111	48
1	3	0	17	0	110	0
134	34	0	22	0	109	11
571	3	0	17	0	106	4
526	2	0	17	0	106	13
9	3	0	16	0	106	4
118	3	2	20	0	106	39
465	3	2	21	0	106	38
54	2	0	17	0	105	14
535	3	0	23	0	105	5
45	3	0	23	0	105	4
292	1	0	14	0	105	1
323	1	0	31	0	104	5

DODATAK D

Proračun i provjera strukturnih elemenata primjenom DNV 3D-Beam programskog alata

Okvir boka garažnog prostora i nadgrađe

Load case No 5 LC1+LC2+LC3+LC4 - Combination : LC1 Poprečno akceleracijsko polje (1), LC2 Palubna opterećenja (1), LC3 Opterećenje od vjetra (1), LC4 Gravitacija (1)

Beam Stresses, values, sorted by Sig-My in Descending order

Beam No.	σ_{Nx} [N/mm ²]	τ_{Qy} [N/mm ²]	τ_{Qz} [N/mm ²]	τ_{Mx} [N/mm ²]	σ_{My} [N/mm ²]	σ_{Mz} [N/mm ²]
287	1	0	10	0	103	0
6	26	0	13	0	102	11
20	10	0	13	0	102	2
289	1	0	43	0	102	1
212	17	1	17	2	102	11
560	13	0	13	0	101	1
424	21	3	21	0	100	37
314	23	0	14	0	100	0
303	23	0	14	0	100	0
177	37	1	21	0	100	11
556	1	0	15	0	100	16
24	1	0	16	0	99	16
327	3	0	19	0	99	8
395	5	2	16	1	99	19
278	3	0	19	0	99	10
279	3	0	20	0	99	9
326	3	0	21	0	98	7
171	26	3	21	0	98	39
114	2	1	21	0	97	19
371	9	3	15	0	97	25
469	2	1	21	0	97	21
94	0	1	8	0	96	10
488	0	1	7	0	96	10
467	4	1	21	0	96	32
168	28	5	21	0	96	73
116	4	2	20	0	96	35
504	1	0	11	0	96	4
427	27	5	21	0	96	71
78	1	0	11	0	96	4
328	8	1	26	0	95	18
226	9	2	15	0	95	21
157	8	1	17	0	94	30
275	10	25	28	1	93	53
562	2	0	15	0	92	3
182	9	8	18	0	92	109
143	3	0	30	0	92	3
18	2	0	15	0	92	3
389	4	0	15	1	91	7
280	5	2	27	0	90	14
14	21	0	12	0	90	1
234	5	1	14	0	89	12
414	15	8	18	0	89	112
564	1	0	39	0	88	11
566	16	0	12	0	88	3
446	1	3	26	0	88	35
397	23	1	14	1	87	9
16	0	0	38	0	87	11
145	3	0	15	0	86	4
524	1	0	14	0	86	17
56	1	0	14	0	86	16

DODATAK D

Proračun i provjera strukturnih elemenata primjenom DNV 3D-Beam programskog alata

Okvir boka garažnog prostora i nadgrađe

Load case No 5 LC1+LC2+LC3+LC4 - Combination : LC1 Poprečno akceleracijsko polje (1), LC2 Palubna opterećenja (1), LC3 Opterećenje od vjetra (1), LC4 Gravitacija (1)

Beam Stresses, values, sorted by Sig-My in Descending order

Beam No.	σ_{Nx} [N/mm ²]	τ_{Qy} [N/mm ²]	τ_{Qz} [N/mm ²]	τ_{Mx} [N/mm ²]	σ_{My} [N/mm ²]	σ_{Mz} [N/mm ²]
320	0	0	12	3	86	7
37	33	0	13	0	85	18
543	33	0	13	0	85	19
388	2	1	15	1	85	8
533	2	0	19	0	85	1
146	3	0	14	0	85	4
202	5	1	14	1	85	15
47	2	0	18	0	85	1
218	6	0	14	3	84	3
297	0	0	12	3	84	7
363	6	2	13	0	84	16
324	9	8	24	1	82	25
387	11	2	13	2	82	15
507	6	0	19	1	81	2
75	7	0	19	1	81	2
442	8	2	14	0	80	2
201	14	3	13	1	80	24
273	10	0	11	0	78	5
291	1	0	30	0	78	1
228	6	1	13	3	78	9
447	1	0	36	0	78	1
135	21	1	15	0	78	49
466	3	6	20	0	78	41
344	8	0	11	0	78	4
253	8	0	11	0	78	8
450	17	0	15	0	77	21
438	9	5	10	0	77	30
123	3	5	22	0	77	39
573	1	1	26	0	76	8
117	3	6	19	0	76	41
330	10	16	30	0	76	44
486	0	2	4	0	76	18
33	0	0	13	0	75	16
547	0	0	13	0	75	16
7	1	1	27	0	75	8
96	0	2	4	0	75	18
460	3	4	22	0	75	33
468	6	6	21	0	75	43
125	2	6	18	0	74	40
294	2	0	32	0	74	1
204	5	3	13	1	73	26
115	5	6	21	0	73	50
13	1	0	32	0	73	2
458	2	6	17	0	72	40
126	2	6	18	0	72	41
295	0	0	42	0	71	1
281	9	1	25	0	71	17
214	18	1	12	2	71	9
457	2	6	17	0	71	39
144	5	0	24	0	70	3

DODATAK D

Proračun i provjera strukturnih elemenata primjenom DNV 3D-Beam programskog alata

Okvir boka garažnog prostora i nadgrađe

Load case No 5 LC1+LC2+LC3+LC4 - Combination : LC1 Poprečno akceleracijsko polje (1), LC2 Palubna opterećenja (1), LC3 Opterećenje od vjetra (1), LC4 Gravitacija (1)

Beam Stresses, values, sorted by Sig-My in Descending order

Beam No.	σ_{Nx} [N/mm ²]	τ_{Qy} [N/mm ²]	τ_{Qz} [N/mm ²]	τ_{Mx} [N/mm ²]	σ_{My} [N/mm ²]	σ_{Mz} [N/mm ²]
74	8	0	17	0	70	2
508	11	0	17	0	70	3
288	1	0	6	0	69	1
153	8	2	9	0	69	5
23	13	0	9	0	69	3
557	11	0	9	0	69	5
402	11	0	12	2	68	4
80	1	1	7	0	68	9
502	1	1	7	0	68	9
353	5	0	10	0	67	1
244	5	0	10	0	67	4
138	1	0	33	0	67	1
73	6	0	17	0	66	0
567	1	0	30	0	66	2
509	4	0	17	0	66	0
217	5	0	11	3	66	2
553	2	0	11	0	66	7
27	2	0	11	0	66	6
51	1	0	13	0	66	4
325	4	2	24	0	66	15
529	1	0	13	0	66	4
290	1	0	38	0	65	1
377	11	2	11	2	65	16
551	14	0	7	0	65	2
487	6	1	10	0	64	10
95	6	1	10	0	64	11
4	2	0	9	0	64	0
299	0	1	48	0	64	11
122	1	1	25	0	63	17
318	0	1	46	0	62	11
485	4	2	8	0	62	13
97	4	2	8	0	62	13
386	12	2	11	2	61	15
71	7	0	17	0	61	0
511	5	0	17	0	61	0
107	2	4	24	0	61	48
522	0	0	11	0	61	14
398	24	0	10	1	61	3
513	6	0	17	0	61	0
68	9	0	17	0	60	0
58	0	0	11	0	60	14
12	1	0	8	0	60	8
568	1	0	8	0	59	7
72	10	0	15	0	59	1
29	8	0	6	0	59	2
215	4	0	8	1	59	2
399	8	2	8	1	59	22
419	4	0	8	0	59	5
176	4	0	8	0	59	5
510	11	0	15	0	59	2

DODATAK D

Proračun i provjera strukturnih elemenata primjenom DNV 3D-Beam programskog alata

Okvir boka garažnog prostora i nadgrađe

Load case No 5 LC1+LC2+LC3+LC4 - Combination : LC1 Poprečno akceleracijsko polje (1), LC2 Palubna opterećenja (1), LC3 Opterećenje od vjetra (1), LC4 Gravitacija (1)

Beam Stresses, values, sorted by Sig-My in Descending order

Beam No.	σ_{Nx} [N/mm ²]	τ_{Qy} [N/mm ²]	τ_{Qz} [N/mm ²]	τ_{Mx} [N/mm ²]	σ_{My} [N/mm ²]	σ_{Mz} [N/mm ²]
495	3	1	8	0	58	4
87	3	1	8	0	58	5
454	13	1	11	0	58	50
53	1	0	11	0	58	11
130	9	0	11	0	58	25
88	1	1	6	2	57	12
527	1	0	11	0	57	10
89	2	1	7	0	57	9
476	2	4	23	0	57	49
493	3	1	7	0	57	9
193	5	1	9	0	57	8
403	5	1	9	0	57	9
170	4	1	8	0	56	5
425	4	1	9	0	56	5
230	5	1	10	2	56	7
494	1	1	6	2	56	12
86	0	1	26	0	56	10
70	14	0	15	0	56	1
305	67	0	10	0	56	0
430	8	7	13	0	56	100
312	67	0	10	0	55	0
512	18	0	14	0	55	1
69	21	0	14	0	55	3
200	23	2	8	1	54	12
501	2	2	3	0	54	10
409	5	1	8	0	54	9
187	5	1	9	0	54	8
81	2	2	3	0	54	11
496	0	1	27	0	54	9
175	4	0	19	0	54	4
420	4	0	18	0	53	4
503	1	1	3	0	53	8
79	1	1	3	0	53	8
484	1	2	4	0	53	20
209	1	1	9	1	53	7
401	10	1	9	2	52	14
198	8	2	6	1	52	27
98	1	2	4	0	52	21
404	5	0	19	0	52	8
477	4	4	17	0	52	49
165	13	7	12	0	52	103
393	5	3	9	1	52	27
382	5	1	6	1	51	7
192	4	0	17	0	51	7
456	1	3	23	0	51	43
142	2	0	46	0	51	3
205	17	1	8	1	50	10
379	6	0	7	3	50	2
31	1	0	22	0	50	4
32	14	0	7	0	50	4

DODATAK D

Proračun i provjera strukturnih elemenata primjenom DNV 3D-Beam programskog alata

Okvir boka garažnog prostora i nadgrađe

Load case No 5 LC1+LC2+LC3+LC4 - Combination : LC1 Poprečno akceleracijsko polje (1), LC2 Palubna opterećenja (1), LC3 Opterećenje od vjetra (1), LC4 Gravitacija (1)

Beam Stresses, values, sorted by Sig-My in Descending order

Beam No.	σ_{Nx} [N/mm ²]	τ_{Qy} [N/mm ²]	τ_{Qz} [N/mm ²]	τ_{Mx} [N/mm ²]	σ_{My} [N/mm ²]	σ_{Mz} [N/mm ²]
49	1	0	10	0	49	12
514	27	0	10	0	49	5
67	26	0	10	0	49	5
282	5	0	22	0	49	6
82	1	1	6	0	49	11
531	1	0	10	0	49	12
500	1	1	6	0	49	11
133	1	1	19	0	49	9
375	10	3	9	1	49	25
481	0	0	22	0	48	1
385	18	2	7	2	48	14
167	4	1	19	0	48	4
308	13	0	12	0	48	1
428	4	1	20	0	48	4
555	0	1	13	1	48	17
21	1	0	6	0	48	12
559	1	0	6	0	47	12
309	14	0	11	0	47	1
127	1	3	22	0	47	42
412	4	1	18	0	46	8
195	11	1	7	2	46	6
184	4	1	18	0	46	7
148	4	0	48	0	46	3
25	0	1	14	1	46	17
293	0	0	15	0	45	2
139	5	3	19	0	45	38
315	1	0	2	0	45	1
548	8	0	6	0	44	6
302	1	0	2	0	44	1
216	4	0	8	2	44	3
60	5	0	7	0	44	0
322	1	0	10	0	44	5
245	8	0	7	0	43	6
352	8	0	7	0	43	3
521	7	0	7	0	43	0
120	4	3	18	0	43	15
199	25	1	5	1	42	7
121	4	1	4	0	42	12
34	2	3	1	1	42	9
100	3	0	6	0	42	5
482	3	0	6	0	42	6
546	2	3	1	1	42	9
174	3	0	31	0	42	3
83	3	2	9	0	42	17
499	3	2	9	0	42	17
421	3	0	31	0	42	2
558	1	0	21	0	41	4
405	4	0	31	1	41	6
55	1	0	8	0	41	13
191	3	0	31	1	41	5

DODATAK D

Proračun i provjera strukturnih elemenata primjenom DNV 3D-Beam programskog alata

Okvir boka garažnog prostora i nadgrađe

Load case No 5 LC1+LC2+LC3+LC4 - Combination : LC1 Poprečno akceleracijsko polje (1), LC2 Palubna opterećenja (1), LC3 Opterećenje od vjetra (1), LC4 Gravitacija (1)

Beam Stresses, values, sorted by Sig-My in Descending order

Beam No.	σ_{Nx} [N/mm ²]	τ_{Qy} [N/mm ²]	τ_{Qz} [N/mm ²]	τ_{Mx} [N/mm ²]	σ_{My} [N/mm ²]	σ_{Mz} [N/mm ²]
264	1	0	8	0	41	2
525	1	0	7	0	40	13
572	3	1	20	0	40	8
451	1	1	16	0	40	9
266	1	0	11	0	40	0
62	4	0	6	0	40	1
383	19	2	4	2	40	11
462	4	5	3	0	39	28
267	1	0	9	0	39	0
42	3	0	8	0	39	12
538	3	0	8	0	39	13
232	4	0	7	1	39	3
519	6	0	6	0	39	1
113	7	2	6	0	39	17
124	3	3	20	0	39	34
84	4	2	12	0	39	9
498	4	2	12	0	39	9
332	1	0	8	0	39	3
77	1	0	1	0	38	4
505	1	0	1	0	38	5
471	8	1	18	0	38	15
22	1	0	19	0	38	4
102	1	0	21	0	37	1
333	0	0	8	0	37	2
131	1	2	35	0	37	9
470	7	6	2	0	37	35
453	1	2	34	0	37	9
373	9	3	7	1	37	31
384	16	2	6	2	36	11
542	68	1	4	0	35	48
38	70	1	4	0	35	50
461	3	1	19	0	35	19
265	1	0	7	0	35	3
90	2	1	15	1	35	8
93	7	0	4	0	35	5
489	7	0	4	0	35	5
59	18	0	5	0	34	2
106	4	4	14	0	34	48
400	9	2	6	1	34	24
577	4	0	1	0	34	0
579	4	0	1	0	34	0
520	12	0	5	0	34	2
317	4	4	61	0	34	41
549	1	0	17	0	33	4
61	15	0	5	0	33	1
492	2	1	16	1	33	9
64	3	0	5	0	33	2
437	8	8	6	0	33	27
17	3	1	12	0	33	10
164	2	1	32	0	33	2

DODATAK D

Proračun i provjera strukturnih elemenata primjenom DNV 3D-Beam programskog alata

Okvir boka garažnog prostora i nadgrađe

Load case No 5 LC1+LC2+LC3+LC4 - Combination : LC1 Poprečno akceleracijsko polje (1), LC2 Palubna opterećenja (1), LC3 Opterećenje od vjetra (1), LC4 Gravitacija (1)

Beam Stresses, values, sorted by Sig-My in Descending order

Beam No.	σ_{Nx} [N/mm ²]	τ_{Qy} [N/mm ²]	τ_{Qz} [N/mm ²]	τ_{Mx} [N/mm ²]	σ_{My} [N/mm ²]	σ_{Mz} [N/mm ²]
517	5	0	5	0	33	2
283	4	0	1	0	32	6
480	1	0	19	0	32	1
431	2	1	33	0	32	2
463	4	1	14	0	32	15
415	3	1	30	0	32	5
300	5	4	61	0	31	41
181	3	1	32	0	31	5
459	4	3	18	0	31	35
364	6	1	3	0	30	26
490	5	4	16	1	30	6
101	0	0	16	0	30	0
92	5	3	16	1	30	6
518	9	0	4	0	30	3
63	10	0	4	0	30	2
497	4	1	2	0	30	4
436	5	9	2	0	29	22
85	4	1	2	0	29	4
563	3	1	10	0	29	10
276	1	1	18	0	28	13
103	2	1	9	1	28	9
213	15	1	5	2	28	9
544	33	1	8	0	28	14
417	47	8	10	0	28	129
30	0	0	2	0	27	12
550	0	0	2	0	27	12
311	39	0	4	0	27	0
8	3	0	15	0	27	7
600	2	0	3	0	27	0
36	33	0	8	0	27	14
306	38	0	4	0	26	0
179	45	8	9	0	26	125
601	2	0	3	0	26	0
66	5	0	4	1	26	4
112	8	3	13	0	26	14
606	2	0	0	0	25	0
516	7	0	4	0	25	3
599	2	0	2	0	25	0
220	11	1	4	2	25	12
612	2	0	0	0	24	0
483	3	3	5	0	24	22
515	6	0	4	1	24	4
65	10	0	3	0	24	2
602	2	0	2	0	24	0
206	23	0	4	1	24	3
233	6	0	2	0	24	24
99	4	3	5	0	24	22
441	2	10	5	0	23	24
91	2	2	5	1	23	16
173	2	0	38	0	23	1

DODATAK D

Proračun i provjera strukturnih elemenata primjenom DNV 3D-Beam programskog alata

Okvir boka garažnog prostora i nadgrađe

Load case No 5 LC1+LC2+LC3+LC4 - Combination : LC1 Poprečno akceleracijsko polje (1), LC2 Palubna opterećenja (1), LC3 Opterećenje od vjetra (1), LC4 Gravitacija (1)

Beam Stresses, values, sorted by Sig-My in Descending order

Beam No.	σ_{Nx} [N/mm ²]	τ_{Qy} [N/mm ²]	τ_{Qz} [N/mm ²]	τ_{Mx} [N/mm ²]	σ_{My} [N/mm ²]	σ_{Mz} [N/mm ²]
304	7	0	3	0	23	0
313	6	0	3	0	22	0
406	2	1	37	0	22	3
422	2	0	36	0	22	1
491	3	2	5	1	22	17
605	1	0	8	0	22	2
224	9	3	4	1	22	29
160	2	6	6	0	22	19
128	1	5	5	0	22	41
190	2	1	35	0	21	3
158	8	7	7	0	21	20
613	1	0	8	0	21	2
391	22	1	3	1	21	5
478	1	1	12	0	21	12
156	8	5	5	0	21	26
464	1	8	4	0	20	60
410	1	5	3	0	20	64
540	0	2	44	0	20	3
435	2	6	3	0	20	19
407	0	2	3	0	19	28
186	4	4	3	0	19	61
40	0	2	43	0	19	3
369	6	0	3	3	19	4
607	2	0	2	0	19	0
554	3	0	10	1	19	7
611	2	0	2	0	19	0
189	4	2	2	0	18	26
104	1	1	11	0	18	13
155	5	5	1	0	18	22
580	36	0	0	0	18	0
455	1	5	5	0	18	41
576	36	0	0	0	18	0
440	5	6	4	0	18	25
545	5	1	14	0	18	6
227	8	0	3	0	18	5
35	5	1	13	0	18	6
41	86	1	4	0	18	59
539	88	1	4	0	18	58
196	11	1	3	2	17	17
119	1	8	4	0	17	59
413	0	7	3	0	17	100
39	7	0	5	0	17	10
162	77	8	3	0	17	123
329	8	1	8	0	16	13
183	3	8	2	0	16	102
541	6	0	5	0	16	10
433	75	8	2	0	16	121
598	1	0	3	0	15	1
154	2	10	3	0	15	24
380	6	0	2	3	15	4

DODATAK D

Proračun i provjera strukturnih elemenata primjenom DNV 3D-Beam programskog alata

Okvir boka garažnog prostora i nadgrađe

Load case No 5 LC1+LC2+LC3+LC4 - Combination : LC1 Poprečno akceleracijsko polje (1), LC2 Palubna opterećenja (1), LC3 Opterećenje od vjetra (1), LC4 Gravitacija (1)

Beam Stresses, values, sorted by Sig-My in Descending order

Beam No.	σ_{Nx} [N/mm ²]	τ_{Qy} [N/mm ²]	τ_{Qz} [N/mm ²]	τ_{Mx} [N/mm ²]	σ_{My} [N/mm ²]	σ_{Mz} [N/mm ²]
523	0	0	2	0	15	11
439	8	7	4	0	15	33
222	11	2	3	2	15	24
57	0	0	1	0	15	10
603	2	0	2	0	14	0
225	6	1	3	0	14	34
479	2	1	3	1	14	9
365	5	0	2	2	14	2
229	6	0	2	0	13	3
392	17	1	1	1	13	12
136	3	1	32	0	12	2
370	3	0	1	0	12	4
449	3	1	31	0	12	2
161	1	0	37	0	11	1
434	1	0	36	0	11	1
418	1	1	35	0	11	2
588	1	0	1	0	11	1
178	1	1	35	0	11	2
585	1	0	2	0	11	0
597	1	0	1	0	10	0
586	1	0	1	0	10	0
592	1	0	2	0	10	0
296	63	4	0	0	10	78
270	5	0	2	0	10	2
159	5	9	4	0	10	22
591	1	0	1	0	9	1
368	1	0	1	0	9	3
321	66	4	0	0	9	76
372	7	1	1	0	9	31
608	1	0	1	0	8	1
378	7	0	2	0	8	3
335	0	0	3	0	8	3
610	2	0	1	0	8	0
163	3	9	2	0	8	129
197	9	2	1	2	8	25
589	1	0	2	0	7	0
609	1	0	1	0	7	1
262	0	0	3	0	7	4
587	1	0	1	0	7	2
596	1	0	2	0	7	0
432	2	10	1	0	7	132
338	2	0	2	0	7	1
376	5	0	2	0	6	1
604	1	0	1	0	6	1
349	1	0	2	0	6	8
359	4	0	3	0	6	2
367	6	1	1	2	6	6
582	1	0	1	0	6	2
584	0	0	2	0	6	0
231	4	0	1	0	6	1

DODATAK D

Proračun i provjera strukturnih elemenata primjenom DNV 3D-Beam programskog alata

Okvir boka garažnog prostora i nadgrađe

Load case No 5 LC1+LC2+LC3+LC4 - Combination : LC1 Poprečno akceleracijsko polje (1), LC2 Palubna opterećenja (1), LC3 Opterećenje od vjetra (1), LC4 Gravitacija (1)

Beam Stresses, values, sorted by Sig-My in Descending order

Beam No.	σ_{Nx} [N/mm ²]	τ_{Qy} [N/mm ²]	τ_{Qz} [N/mm ²]	τ_{Mx} [N/mm ²]	σ_{My} [N/mm ²]	σ_{Mz} [N/mm ²]
259	2	0	1	0	6	2
172	1	2	1	0	5	25
248	1	0	1	0	5	12
269	5	0	1	0	5	1
219	3	0	2	0	5	2
593	0	0	2	0	5	0
169	0	4	1	0	5	59
374	4	0	1	0	5	3
423	3	2	0	0	5	23
180	1	10	1	0	4	132
381	5	1	0	2	4	5
211	11	1	0	2	4	13
223	2	0	2	0	4	7
238	4	2	2	0	4	16
242	1	1	2	0	4	6
426	3	4	0	0	4	56
221	2	0	1	0	4	1
26	3	0	4	1	4	7
416	2	10	0	0	3	132
254	1	1	2	0	3	16
343	1	4	1	0	3	48
337	1	0	1	0	3	3
358	0	1	2	0	3	3
361	1	0	1	0	3	7
336	1	0	1	0	3	4
429	2	7	1	0	3	93
241	2	2	1	0	3	21
260	1	0	1	0	3	2
362	0	0	1	0	3	1
236	1	0	1	0	3	9
366	1	0	1	0	3	3
339	0	1	2	0	3	11
257	0	1	1	0	3	9
346	0	1	2	0	3	3
261	1	0	1	0	2	1
340	0	2	0	0	2	11
268	5	0	0	0	2	2
239	0	2	1	0	2	14
235	0	0	1	0	2	4
251	0	3	1	0	2	27
258	0	1	2	0	2	9
590	0	0	1	0	2	0
355	1	1	2	0	2	7
252	0	2	2	0	2	11
345	0	2	2	0	2	16
583	0	0	1	0	2	1
356	2	1	0	0	2	6
594	0	0	1	0	2	1
595	0	0	1	0	1	0
255	0	1	1	0	1	14

DODATAK D

Proračun i provjera strukturnih elemenata primjenom DNV 3D-Beam programskog alata

Okvir boka garažnog prostora i nadgrađe

Load case No 5 LC1+LC2+LC3+LC4 - Combination : LC1 Poprečno akceleracijsko polje (1), LC2 Palubna opterećenja (1), LC3 Opterećenje od vjetra (1), LC4 Gravitacija (1)

Beam Stresses, values, sorted by Sig-My in Descending order

Beam No.	σ_{Nx} [N/mm ²]	τ_{Qy} [N/mm ²]	τ_{Qz} [N/mm ²]	τ_{Mx} [N/mm ²]	σ_{My} [N/mm ²]	σ_{Mz} [N/mm ²]
334	0	0	1	0	1	2
341	0	1	1	0	1	12
298	69	7	0	0	1	149
250	0	0	1	1	1	6
319	66	7	0	0	1	150
342	0	1	1	0	1	12
347	0	0	1	0	1	1
256	0	2	0	0	1	13
166	0	7	0	0	1	92
263	0	0	0	0	1	2
105	11	3	0	0	0	53
129	35	8	0	0	0	173
141	39	4	0	0	0	80

Combined Element stresses

Beam No.	σ_{Ny} (min) [N/mm ²]	σ_{Ny} (max) [N/mm ²]	σ_{Nz} (min) [N/mm ²]	σ_{Nz} (max) [N/mm ²]
307	369	227	71	70
310	369	227	71	70
360	212	161	13	7
350	225	76	28	16
443	217	68	47	17
152	214	67	47	17
249	108	188	14	8
150	199	79	40	35
445	197	78	40	35
271	210	161	27	8
285	199	120	12	7
351	114	169	39	4
237	197	113	15	3
247	206	71	33	6
272	131	176	18	0
137	204	166	62	22
448	191	151	85	36
2	98	171	4	3
348	93	164	16	2
140	199	131	52	24
10	94	166	8	2
570	94	166	9	3
44	102	163	7	2
536	103	162	8	1
246	98	145	39	3
194	182	123	59	22
188	160	143	61	21
76	197	107	39	33
506	197	107	39	33
203	143	153	6	34
277	159	67	20	22
108	171	146	58	35

DODATAK D

Proračun i provjera strukturnih elemenata primjenom DNV 3D-Beam programskog alata

Okvir boka garažnog prostora i nadgrađe

Combined Element stresses

Beam No.	σ_{Ny} (min) [N/mm ²]	σ_{Ny} (max) [N/mm ²]	σ_{Nz} (min) [N/mm ²]	σ_{Nz} (max) [N/mm ²]
408	165	132	71	16
109	164	146	54	45
394	141	149	5	38
46	94	154	10	1
534	95	154	10	2
474	169	138	47	24
390	139	147	14	29
19	82	152	6	1
475	162	145	62	43
561	82	152	6	1
331	140	77	12	39
411	162	118	113	48
3	179	83	46	12
185	159	119	108	48
207	129	131	4	22
147	141	64	2	7
48	76	138	5	2
532	76	138	5	2
210	125	125	16	2
569	158	76	25	24
28	70	132	11	6
552	70	131	11	7
578	140	127	7	7
574	138	125	7	6
11	147	81	18	15
243	140	53	14	7
240	138	54	18	0
151	61	121	37	21
444	61	121	38	22
452	146	102	55	17
473	130	114	52	43
110	136	108	46	25
274	113	63	12	36
575	98	149	25	25
284	130	52	11	5
5	63	120	2	1
581	96	147	26	26
50	64	120	17	13
530	63	119	18	14
149	108	60	7	14
316	143	93	25	25
301	142	93	25	24
208	94	121	1	14
472	129	99	53	29
528	61	115	7	3
52	61	114	8	4
565	60	115	11	8
15	60	114	11	9
396	111	101	35	8
357	122	48	14	3
537	117	96	6	0
43	117	95	5	1
354	121	47	15	1
132	128	90	74	30

DODATAK D

Proračun i provjera strukturnih elemenata primjenom DNV 3D-Beam programskog alata

Okvir boka garažnog prostora i nadgrađe

Combined Element stresses

Beam No.	σ_{Ny} (min) [N/mm ²]	σ_{Ny} (max) [N/mm ²]	σ_{Nz} (min) [N/mm ²]	σ_{Nz} (max) [N/mm ²]
286	57	110	2	0
111	121	95	58	37
1	113	92	3	3
134	137	74	45	23
571	109	89	7	2
526	55	104	15	12
9	109	89	7	1
118	46	103	42	36
465	46	103	42	35
54	55	104	16	12
535	108	88	7	2
45	108	88	7	2
292	54	104	1	0
323	105	42	6	4
287	53	102	1	0
6	128	50	37	15
20	112	66	12	8
289	53	101	2	0
212	103	84	21	6
560	114	63	14	12
424	108	79	58	16
314	123	77	23	23
303	122	77	23	22
177	123	63	48	26
556	51	99	17	15
24	51	99	17	15
327	38	102	4	11
395	76	103	15	11
278	38	101	7	13
279	38	101	7	12
326	38	102	5	10
171	111	72	65	13
114	39	99	18	20
371	106	64	16	16
469	39	99	20	22
94	49	96	10	10
488	49	96	10	11
467	43	93	36	28
168	111	68	101	45
116	43	93	39	31
504	48	96	4	5
427	110	69	98	44
78	48	96	3	5
328	87	47	10	26
226	104	64	30	3
157	16	103	4	38
275	14	103	13	63
562	95	78	5	0
182	89	84	118	100
143	90	49	0	5
18	95	77	5	0
389	72	95	3	6
280	86	42	9	18
14	111	46	23	20

DODATAK D

Proračun i provjera strukturnih elemenata primjenom DNV 3D-Beam programskog alata

Okvir boka garažnog prostora i nadgrađe

Combined Element stresses

Beam No.	σ_{Ny} (min) [N/mm ²]	σ_{Ny} (max) [N/mm ²]	σ_{Nz} (min) [N/mm ²]	σ_{Nz} (max) [N/mm ²]
234	94	57	17	1
414	92	73	127	96
564	45	88	11	10
566	104	50	19	13
446	88	36	35	35
397	94	65	32	20
16	45	86	11	10
145	33	89	2	7
524	45	85	18	15
56	45	85	18	15
320	44	85	7	7
37	76	52	51	15
543	76	52	52	14
388	86	83	5	6
533	87	71	3	1
146	32	88	1	7
202	65	90	0	20
47	87	71	3	1
218	90	64	9	5
297	43	84	7	7
363	89	55	11	10
324	30	73	34	1
387	76	70	27	4
507	76	75	8	3
75	76	74	9	4
442	28	72	10	7
201	80	65	22	9
273	88	35	15	1
291	39	79	0	1
228	84	64	9	4
447	41	77	2	1
135	99	53	70	28
466	81	24	44	37
344	86	29	12	5
253	86	29	16	0
450	94	56	38	4
438	11	86	22	22
123	73	38	36	42
573	39	76	9	8
117	80	23	44	37
330	9	86	34	29
486	38	76	17	18
33	38	75	16	15
547	38	75	16	16
7	39	75	9	8
96	38	75	18	19
460	71	44	30	37
468	80	26	49	38
125	72	28	38	42
294	42	76	1	3
204	73	68	32	3
115	79	31	55	44
13	38	72	3	1
458	70	28	38	42

DODATAK D

Proračun i provjera strukturnih elemenata primjenom DNV 3D-Beam programskog alata

Okvir boka garažnog prostora i nadgrađe

Combined Element stresses

Beam No.	σ_{Ny} (min) [N/mm ²]	σ_{Ny} (max) [N/mm ²]	σ_{Nz} (min) [N/mm ²]	σ_{Nz} (max) [N/mm ²]
126	70	27	39	43
295	71	35	1	0
281	27	61	16	7
214	81	53	23	9
457	68	27	36	41
144	65	34	3	8
74	68	63	10	6
508	71	58	14	8
288	36	68	2	0
153	25	61	10	2
23	82	39	16	10
557	80	41	16	6
402	79	49	15	10
80	34	69	8	10
502	34	69	8	10
353	72	28	6	4
244	71	28	8	0
138	35	66	2	1
73	63	60	6	6
567	35	65	3	1
509	61	62	4	3
217	65	61	7	5
553	68	55	8	5
27	68	55	8	5
51	67	55	6	3
325	62	31	11	18
529	67	55	5	2
290	49	64	2	0
377	76	49	16	5
551	79	35	16	12
487	30	58	16	4
95	30	58	17	5
4	65	54	2	1
299	58	64	11	12
122	64	40	18	17
318	53	63	11	12
485	28	58	17	8
97	28	57	17	9
386	67	50	18	3
71	63	54	7	7
511	61	56	5	4
107	63	33	50	46
522	31	61	14	14
398	73	36	27	23
513	65	55	6	5
68	66	52	9	8
58	30	60	14	14
12	61	50	9	6
568	61	50	9	6
72	60	50	10	9
29	67	37	10	5
215	63	26	5	2
399	67	16	29	1
419	54	63	1	9

DODATAK D

Proračun i provjera strukturnih elemenata primjenom DNV 3D-Beam programskog alata

Okvir boka garažnog prostora i nadgrađe

Combined Element stresses

Beam No.	σ_{Ny} (min) [N/mm ²]	σ_{Ny} (max) [N/mm ²]	σ_{Nz} (min) [N/mm ²]	σ_{Nz} (max) [N/mm ²]
176	54	63	1	10
510	62	47	13	10
495	25	55	8	1
87	25	55	8	2
454	71	42	63	37
53	59	49	12	9
130	67	45	34	15
88	28	59	11	13
527	59	48	11	9
89	24	55	11	6
476	59	30	51	48
493	24	55	11	6
193	52	62	4	13
403	52	62	4	14
170	52	60	1	9
425	52	60	1	9
230	61	44	7	2
494	27	57	11	13
86	50	56	9	10
70	61	42	14	13
305	123	11	67	67
430	56	47	108	92
312	122	12	67	67
512	65	37	19	17
69	68	34	23	18
200	61	31	29	11
501	22	53	12	9
409	50	59	4	13
187	50	59	4	13
81	22	52	13	9
496	53	55	9	10
175	50	58	0	8
420	49	57	0	8
503	21	52	9	7
79	21	52	10	7
484	26	54	19	21
209	54	46	8	1
401	58	42	24	6
198	61	13	17	19
98	26	53	20	22
404	48	57	3	12
477	56	17	53	45
165	58	39	116	90
393	56	47	13	23
382	56	16	12	1
192	47	56	3	12
456	52	40	44	42
142	19	53	1	5
205	58	33	28	14
379	30	43	7	4
31	26	49	5	3
32	63	24	18	9
49	51	41	13	11
514	70	23	32	22

DODATAK D

Proračun i provjera strukturnih elemenata primjenom DNV 3D-Beam programskog alata

Okvir boka garažnog prostora i nadgrađe

Combined Element stresses

Beam No.	σ_{Ny} (min) [N/mm ²]	σ_{Ny} (max) [N/mm ²]	σ_{Nz} (min) [N/mm ²]	σ_{Nz} (max) [N/mm ²]
67	70	23	31	21
282	44	37	1	10
82	24	50	10	12
531	50	41	13	11
500	23	50	9	12
133	23	50	8	10
375	59	35	18	15
481	25	48	1	0
385	49	30	32	13
167	44	52	1	8
308	35	61	12	14
428	44	51	0	7
555	24	48	17	17
21	49	40	13	11
559	48	40	13	11
309	34	61	13	14
127	47	37	42	41
412	42	51	3	12
195	39	35	13	6
184	42	50	3	11
148	15	50	1	7
25	23	46	17	18
293	22	45	1	2
139	41	23	34	42
315	46	43	2	1
548	53	25	14	2
302	45	43	1	0
216	45	39	8	3
60	49	33	5	5
322	19	42	6	4
245	27	37	14	2
352	27	37	11	4
521	49	30	7	6
120	11	46	11	19
199	42	17	29	18
121	11	46	8	16
34	44	41	10	7
100	45	40	8	2
482	45	39	8	3
546	44	41	10	7
174	39	45	0	6
83	18	39	20	15
499	18	39	20	15
421	39	45	1	5
558	22	41	4	3
405	38	45	2	9
55	42	35	13	12
191	37	44	2	9
264	24	40	2	1
525	41	34	13	12
572	25	42	5	10
451	19	41	7	10
266	24	39	1	0
62	43	30	4	3

DODATAK D

Proračun i provjera strukturnih elemenata primjenom DNV 3D-Beam programskog alata

Okvir boka garažnog prostora i nadgrađe

Combined Element stresses

Beam No.	σ_{Ny} (min) [N/mm ²]	σ_{Ny} (max) [N/mm ²]	σ_{Nz} (min) [N/mm ²]	σ_{Nz} (max) [N/mm ²]
383	34	21	30	9
462	10	43	24	31
267	24	39	1	0
42	23	36	16	9
538	23	36	16	10
232	44	29	5	1
519	45	28	7	5
113	21	32	24	10
124	42	28	37	31
84	43	35	12	5
498	43	35	12	5
332	23	38	3	2
77	15	38	5	4
505	15	38	5	4
471	21	30	23	7
22	20	37	4	3
102	20	37	2	1
333	22	37	2	2
131	36	38	8	9
470	20	30	42	28
453	36	38	8	9
373	45	27	18	23
384	46	20	24	5
542	103	41	116	19
38	105	43	119	20
461	21	38	16	22
265	21	35	4	3
90	18	37	7	10
93	20	28	12	2
489	20	28	12	2
59	52	12	19	16
106	38	10	52	43
400	41	25	33	1
577	38	30	4	4
579	37	30	4	4
520	46	17	14	10
317	18	29	45	37
549	18	33	4	3
61	48	14	16	14
492	23	35	7	10
64	36	25	5	2
437	25	16	19	20
17	30	19	7	13
164	30	35	0	5
517	37	23	6	3
283	9	37	1	10
480	17	32	2	0
431	30	35	0	5
463	7	36	11	19
415	29	34	2	8
300	18	27	46	37
181	29	34	2	8
459	27	27	39	32
364	36	17	31	20

DODATAK D

Proračun i provjera strukturnih elemenata primjenom DNV 3D-Beam programskog alata

Okvir boka garažnog prostora i nadgrađe

Combined Element stresses

Beam No.	σ_{Ny} (min) [N/mm ²]	σ_{Ny} (max) [N/mm ²]	σ_{Nz} (min) [N/mm ²]	σ_{Nz} (max) [N/mm ²]
490	35	26	11	1
101	16	30	1	0
92	35	26	11	1
518	39	17	11	6
63	40	16	12	8
497	15	26	7	0
436	24	13	15	27
85	15	26	8	1
563	26	17	8	13
276	10	30	12	15
103	13	30	7	10
213	37	12	25	10
544	61	9	48	19
417	19	73	82	176
30	27	23	12	12
550	27	23	12	12
311	12	66	39	39
8	20	29	5	10
600	28	25	2	1
36	59	10	47	19
306	12	65	38	39
179	19	70	80	170
601	28	25	2	1
66	31	17	10	1
112	17	17	22	6
606	27	24	2	1
516	32	14	10	4
599	26	23	2	1
220	36	10	23	8
612	26	23	2	1
483	13	21	25	18
515	30	15	10	1
65	34	11	12	7
602	26	22	2	2
206	37	1	25	22
233	30	12	30	18
99	12	20	25	18
441	9	21	26	20
91	11	20	19	14
173	21	25	0	3
304	16	29	6	7
313	16	28	6	6
406	20	24	1	5
422	20	24	1	3
491	11	19	19	14
605	23	21	3	1
224	26	12	39	0
160	9	23	17	10
128	7	23	40	42
190	20	23	1	5
158	14	27	3	28
613	22	20	3	1
391	34	1	24	17
478	20	19	11	14

DODATAK D

Proračun i provjera strukturnih elemenata primjenom DNV 3D-Beam programskog alata

Okvir boka garažnog prostora i nadgrađe

Combined Element stresses

Beam No.	σ_{Ny} (min) [N/mm ²]	σ_{Ny} (max) [N/mm ²]	σ_{Nz} (min) [N/mm ²]	σ_{Nz} (max) [N/mm ²]
156	28	2	19	19
464	8	19	61	58
410	17	21	63	65
540	20	20	3	3
435	17	7	6	21
407	17	20	28	29
186	21	15	65	57
40	19	19	4	3
369	26	9	11	5
607	21	18	2	1
554	7	21	4	10
611	20	17	2	2
189	20	14	30	22
104	17	17	11	14
155	23	0	15	18
580	54	18	36	36
455	5	19	40	42
576	54	18	36	36
440	10	13	30	5
545	13	22	1	10
227	21	10	12	3
35	13	22	1	10
41	103	73	144	27
539	105	74	146	29
196	25	7	16	7
119	7	16	60	58
413	14	17	100	101
39	23	8	16	3
162	60	91	46	200
329	2	25	4	21
183	17	13	105	98
541	22	8	16	4
433	59	89	45	196
598	17	14	2	1
154	17	2	24	21
380	17	9	7	2
523	15	13	11	11
439	17	7	41	6
222	25	2	35	3
57	14	13	10	11
603	16	13	2	1
225	20	4	40	28
479	6	15	8	11
365	14	8	7	5
229	16	7	9	3
392	22	5	21	5
136	15	10	5	0
370	12	9	6	1
449	14	9	5	0
161	10	12	0	2
434	10	12	0	1
418	10	12	1	3
588	12	10	2	0
178	10	12	1	3

DODATAK D

Proračun i provjera strukturnih elemenata primjenom DNV 3D-Beam programskog alata

Okvir boka garažnog prostora i nadgrađe

Combined Element stresses

Beam No.	σ_{Ny} (min) [N/mm ²]	σ_{Ny} (max) [N/mm ²]	σ_{Nz} (min) [N/mm ²]	σ_{Nz} (max) [N/mm ²]
585	11	10	1	1
597	11	9	1	1
586	11	9	2	1
592	11	9	1	1
296	73	53	141	15
270	15	0	8	3
159	5	14	17	23
591	10	8	2	0
368	8	8	4	3
321	74	56	141	11
372	15	0	37	24
608	10	7	2	1
378	15	0	9	4
335	7	8	3	3
610	10	6	2	1
163	5	10	126	132
197	17	6	17	16
589	8	7	1	0
609	8	6	2	1
262	6	7	4	3
587	8	6	2	1
596	8	6	1	0
432	4	8	130	135
338	8	2	3	1
376	11	0	7	4
604	8	5	2	1
349	7	3	9	7
359	2	9	2	7
367	12	4	12	4
582	7	5	2	1
584	6	5	1	0
231	10	0	5	3
259	7	2	4	1
172	5	5	26	25
248	6	3	13	11
269	10	2	7	3
219	7	2	5	1
593	6	5	1	0
169	4	4	59	59
374	8	0	7	0
423	7	1	26	20
180	3	5	132	133
381	10	4	7	1
211	13	7	24	7
223	6	2	8	5
238	0	7	12	20
242	5	2	7	6
426	7	1	59	53
221	5	2	3	1
26	1	5	4	10
416	1	6	130	135
254	4	1	17	15
343	4	1	49	47
337	4	2	4	2

DODATAK D

Proračun i provjera strukturnih elemenata primjenom DNV 3D-Beam programskog alata

Okvir boka garažnog prostora i nadgrađe

Combined Element stresses

Beam No.	σ_{Ny} (min) [N/mm ²]	σ_{Ny} (max) [N/mm ²]	σ_{Nz} (min) [N/mm ²]	σ_{Nz} (max) [N/mm ²]
358	2	3	4	3
361	3	3	7	6
336	3	2	5	3
429	5	1	95	91
241	4	0	23	18
260	3	2	3	0
362	2	2	2	1
236	2	2	10	9
366	4	1	4	2
339	3	2	11	11
257	2	2	8	9
346	3	1	4	3
261	3	1	2	0
340	2	2	10	11
268	6	3	7	3
239	1	2	14	14
235	2	2	4	4
251	2	1	27	26
258	2	2	9	9
590	2	2	1	0
355	2	1	7	6
252	2	2	12	11
345	2	1	16	16
583	2	2	1	0
356	3	1	9	4
594	2	1	1	0
595	2	1	1	0
255	1	1	13	14
334	1	1	2	2
341	1	1	11	12
298	70	68	217	80
250	1	1	6	6
319	67	64	215	85
342	1	1	12	12
347	1	1	1	1
256	1	1	13	14
166	1	1	92	91
263	1	0	2	2
105	12	11	64	42
129	35	34	208	138
141	39	39	119	41

DODATAK D

Proračun i provjera strukturnih elemenata primjenom DNV 3D-Beam programskog alata

Okvir boka garažnog prostora i nadgrađe

Abbreviations

Principal stresses:

- σ_{Nx} : Axial stress (N_x/A_x)
- τ_{Mx} : Torsional stress (M_x/W_x)
- τ_{Qy} : Shear stress in local y-direction (Q_y/A_y)
- τ_{Qz} : Shear stress in local z-direction (Q_z/A_z)
- σ_{My} : Bending stress about local y-axis (M_y/W_y)
- σ_{Mz} : Bending stress about local z-axis (M_z/W_z)

Stress combinations:

- $\sigma_{Ny(\min)}$: Normal stress in local xz-plane, max of ($\sigma_{Nx} + \sigma_{My(\min)}$)
- $\sigma_{Ny(\max)}$: Normal stress in local xz-plane, max of ($\sigma_{Nx} + \sigma_{My(\max)}$)
- $\sigma_{Nz(\min)}$: Normal stress in local xy-plane, max of ($\sigma_{Nx} + \sigma_{Mz(\min)}$)
- $\sigma_{Nz(\max)}$: Normal stress in local xy-plane, max of ($\sigma_{Nx} + \sigma_{Mz(\max)}$)

Where:

- A_x : Axial area (total profile area)
- A_y : Shear area in local y-direction ($I_z t_p / S_z$)
- A_z : Shear area in local z-direction ($I_y t_p / S_y$)
- W_x : Torsion section modulus
- W_y : Minimum section modulus about local y-axis
- W_z : Minimum section modulus about local z-axis
- N_x : Axial force
- Q_y : Shear force in local y-direction
- Q_z : Shear force in local z-direction
- M_x : Torsional moment
- M_y : Bending moment about local y-axis
- M_z : Bending moment about local z-axis
- S_y, S_z : 1st area moment about y- and z- axis respectively
- t_p : profile thickness value depending on profile type

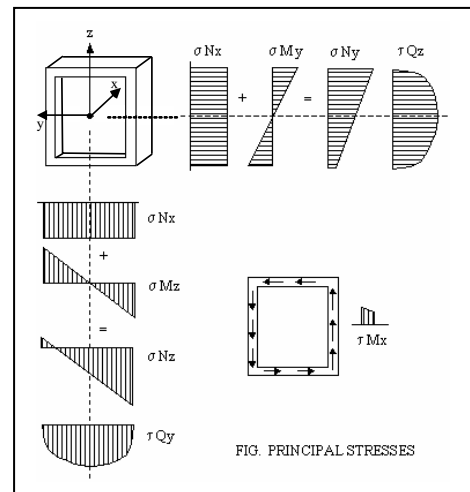

DODATAK E

Proračun i provjera strukturnih elemenata primjenom DNV 3D-Beam programskog alata

Naprezanje strukture dna uslijed dokovanja

Beam information, sorted by Beam in Ascending order

Beam	Beam Name	Start Node	End Node	Elastic Length [mm]	Mass [kg]	Profile	Angle [deg]	Rigid Start [mm]	Rigid End [mm]	Hinged at Start	Hinged at End	Non Linearities
1		1	2	4209,3	1003	6	0,0	0	0			
2		2	3	2407,5	627	10	0,0	0	0			
3		5	4	2407,5	627	10	0,0	0	0			
4		1	5	4209,3	1003	6	0,0	0	0			

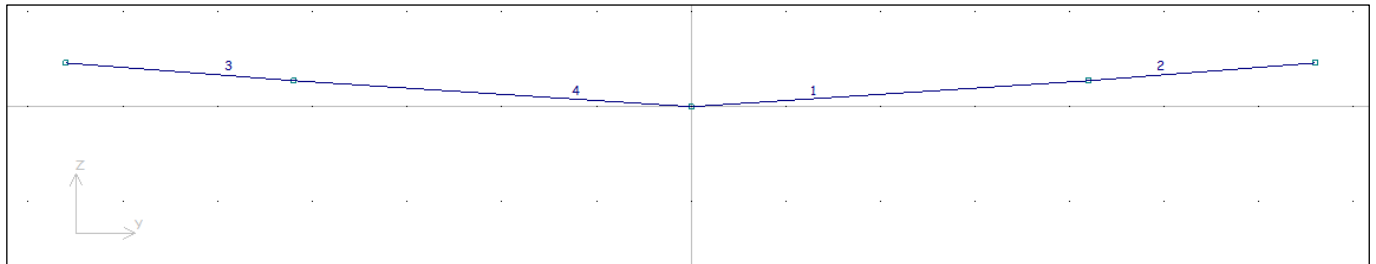

Abbreviations

Beam information:

- Beam: Beam identification number
- Beam Name: User's beam identification
- Start/End Node: Node numbers for the start and end nodes respectively
- Elastic length: Elastic length of beam, excluding possible rigid ends
- Mass: Mass of the elastic length of beam
- Profile: Profile identification number
- Angle: Angle between the profile's z-axis and the plane through the beam and the global Z-axis. Positive for clockwise rotation when seen in positive local x-direction.
- Rigid Start/End: Length of possible rigid part of the beam at the start and end ends respectively
- Hinged at Start/End: Possibly defined hinge at the start and end nodes respectively, where hinges are defined as:
 - dX, dY, dZ: Hinged with respect to translation in the global X-, Y-, and Z-direction respectively
 - rX, rY, rZ: Hinged with respect to rotation about the global X-, Y-, and Z-axis respectively
- Non Linearities: Possibly specified non-linear properties for the beam. For definition see figure below.

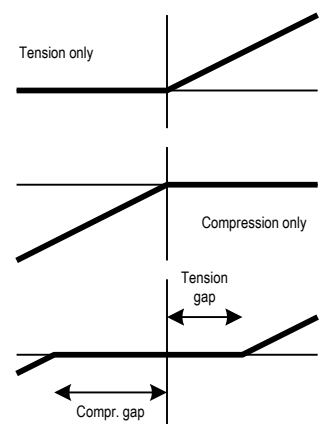

DODATAK E

Proračun i provjera strukturnih elemenata primjenom DNV 3D-Beam programskog alata

Naprezanje strukture dna uslijed dokovanja

Node information, sorted by Node in Ascending order

Node No	Name	X [mm]	Y [mm]	Z [mm]	Boundary Conditions					
					X transl	Y transl	Z transl	X rot	Y rot	Z rot
1		0	0	0						
2	L7	0	4200	280						
3	L11	0	6600	470	Fixed	Fixed	Fixed	Fixed	Fixed	Fixed
4	L-11	0	-6600	470	Fixed	Fixed	Fixed	Fixed	Fixed	Fixed
5	L-7	0	-4200	280						

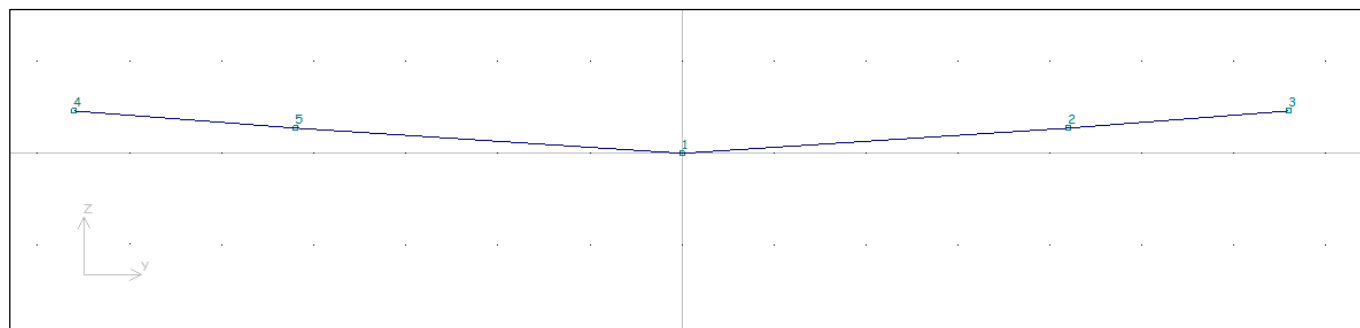

Abbreviations

Node No: Node identification number
Name: User's node identification
X, Y, Z: Node coordinates in the global coordinate system
X transl, Y transl, Z transl: Boundary conditions w.r.t. translation along the global axes
X rot, Y rot, Zrot: Boundary conditions w.r.t. rotation about the global axes

Where:
Free: The node is free
Fixed: The node is fixed
FD: The node has a prescribed displacement or rotation
Spring: The node is supported by a spring

DODATAK E

Proračun i provjera strukturnih elemenata primjenom DNV 3D-Beam programskog alata

Naprezanje strukture dna uslijed dokovanja

Profiles used in the model

Profiles

Profile	Profile Name	Type	Material	Ignore S. C.	Shear factor fy	Shear factor fz	Profile parameters
6	Dno L0-L7	92	1 VL-NS Mild Steel		1,00	1,00	Upper Flange Width=1760 [mm], Upper Flange Thickness=7 [mm], Web Height between flanges=1919 [mm], Web Thickness=2.16 [mm], Lower Flange Width=1760 [mm], Lower Flange Thickness=8 [mm], Radius, web & flanges=0 [mm], Radius, flange corner=0 [mm], FlipY=True
10	Dno L7-L11	92	1 VL-NS Mild Steel		1,00	1,00	Upper Flange Width=1760 [mm], Upper Flange Thickness=7 [mm], Web Height between flanges=1919 [mm], Web Thickness=3.655 [mm], Lower Flange Width=1760 [mm], Lower Flange Thickness=8 [mm], Radius, web & flanges=0 [mm], Radius, flange corner=0 [mm], FlipY=True

Profile properties

Profile	Axial			Local x-z plane				Local x-y plane				Shear Centre	
	Ax [mm ²]	Wx [mm ³]	Ix [mm ⁴]	Az [mm ²]	Wy _t [mm ³]	Wy _b [mm ³]	Iy [mm ⁴]	Ay [mm ²]	Wz+ [mm ³]	Wz- [mm ³]	Iz [mm ⁴]	e _y [mm]	e _z [mm]
6	30545	63506	5,0805e+05	4059	28157435	25115408	2,5673e+10	17600	7744002	7744002	6,8147e+09	0	8,748
10	33414	66604	5,3283e+05	6762	28979905	26106826	2,6562e+10	17600	7744009	7744009	6,8147e+09	0	13,53

Materials

Material	Material Name	E [N/mm ²]	Density [kg/m ³]	Poisson	Thermal Coefficient [mm/mm/C]	Yield Stress [N/mm ²]	Ultimate Strength [N/mm ²]
1	VL-NS Mild Steel	210000	7800,0	0,30	1,26e-05	235	400

Abbreviations

Profiles:

Profile: Profile identification number

Profile Name: User's profile identification

Type: Profile type

Material: Material identification

Ignore S.C.: If ticked "X", then the program ignores the possible shear centre offset for the profile.

Shear factors fy, fz: The shear factor may be < 1.0 for beams with large cut-outs. The factors affect the beam stiffness but not the computed shear stress.

Profile parameters: Input parameters defining the profile.

Profile properties:

Profile: Profile identification number

Ax: Axial area (total profile area)

Wx: Torsion section modulus

Ix: Torsional moment of inertia

Az: Shear area in local z-direction ($I_y t_p / S_y$)

Wy_t: Section modulus about local y-axis at top of profile

Wy_b: Section modulus about local y-axis at bottom of profile

Iy: Moment of inertia about local y-axis

Ay: Shear area in local y-direction ($I_z t_p / S_z$)

Wz+: Section modulus about local z-axis on positive y-side of profile

Wz-: Section modulus about local z-axis on negative y-side of profile

Iz: Moment of inertia about local z-axis

Note: $Wz_t = Wz_b = Wz_{min}$ for all profile types except I - types

DODATAK E

Proračun i provjera strukturnih elemenata primjenom DNV 3D-Beam programskog alata

Naprezanje strukture dna uslijed dokovanja

e_y :	Shear centre distance from vertical neutral axis
e_z :	Shear centre distance from horizontal neutral axis
f_y :	Shear factor in local y-direction
f_z :	Shear factor in local z-direction
	Note: The shear factor is used for shear stiffness of beam, but not for calculation of shear stress

Where:

S_y, S_z :	1 st area moment about y- and z- axis respectively
t_p :	value for profile thickness depending on profile type

Materials:

Material:	Material identification
Material Name:	User's material identification
E:	Young's Modulus
Density:	Density
Poisson:	Poisson's ratio for transverse contraction
Thermal Coefficient:	Coefficient of thermal expansion
Yield Stress:	Nominal yield stress
Ultimate Strength:	Nominal ultimate tensile strength

DODATAK E

Proračun i provjera strukturnih elemenata primjenom DNV 3D-Beam programskog alata

Naprezanje strukture dna uslijed dokovanja

Load case No 1 Opterećenje uslijed dokovanja

Node Loads in global coordinate system, sorted by Node in Ascending order

	Px [N]	Py [N]	Pz [N]	Mx [Nmm]	My [Nmm]	Mz [Nmm]
1	0	0	637650	0	0	0

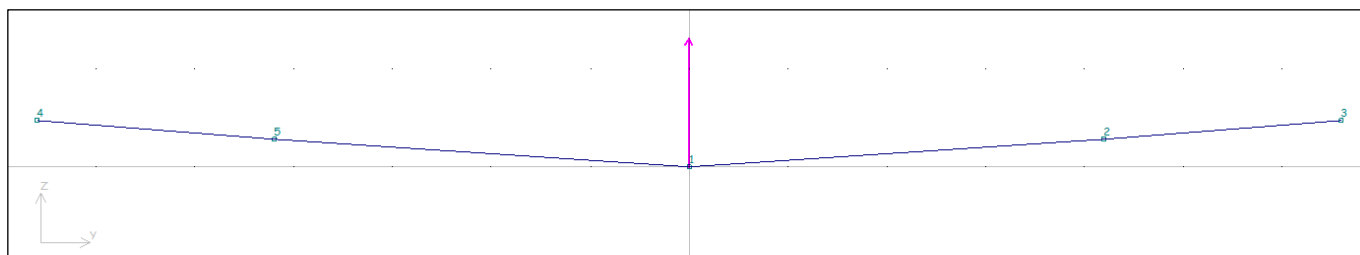

Abbreviations

Node No: Node identification number

Px, Py, Pz: Node load in global X-, Y-, and Z- direction

Mx, My, Mz: Node moment about global X-, Y-, and Z- axis (positive for right-handed screw)

DODATAK E

Proračun i provjera strukturnih elemenata primjenom DNV 3D-Beam programskog alata

Naprezanje strukture dna uslijed dokovanja

Load case No 1 Opterećenje uslijed dokovanja

Beam Stresses, values, sorted by Tau-Qz in Descending order

Beam No.	σ_{Nx} [N/mm ²]	τ_{Qy} [N/mm ²]	τ_{Qz} [N/mm ²]	τ_{Mx} [N/mm ²]	σ_{My} [N/mm ²]	σ_{Mz} [N/mm ²]
1	14	0	72	0	38	0
4	14	0	72	0	38	0
2	13	0	42	0	37	0
3	13	0	42	0	37	0

Combined Element stresses

Beam No.	σ_{Ny} (min) [N/mm ²]	σ_{Ny} (max) [N/mm ²]	σ_{Nz} (min) [N/mm ²]	σ_{Nz} (max) [N/mm ²]
1	52	19	14	14
4	52	19	14	14
2	46	24	13	13
3	46	24	13	13

Abbreviations

Principal stresses:

- σ_{Nx} : Axial stress (N_x/A_x)
- τ_{Mx} : Torsional stress (M_x/W_x)
- τ_{Qy} : Shear stress in local y-direction (Q_y/A_y)
- τ_{Qz} : Shear stress in local z-direction (Q_z/A_z)
- σ_{My} : Bending stress about local y-axis (M_y/W_y)
- σ_{Mz} : Bending stress about local z-axis (M_z/W_z)

Stress combinations:

- $\sigma_{Ny}(\min)$: Normal stress in local xz-plane, max of ($\sigma_{Nx} + \sigma_{My}(\min)$)
- $\sigma_{Ny}(\max)$: Normal stress in local xz-plane, max of ($\sigma_{Nx} + \sigma_{My}(\max)$)
- $\sigma_{Nz}(\min)$: Normal stress in local xy-plane, max of ($\sigma_{Nx} + \sigma_{Mz}(\min)$)
- $\sigma_{Nz}(\max)$: Normal stress in local xy-plane, max of ($\sigma_{Nx} + \sigma_{Mz}(\max)$)

Where:

- A_x : Axial area (total profile area)
- A_y : Shear area in local y-direction ($I_z t_p / S_z$)
- A_z : Shear area in local z-direction ($I_y t_p / S_y$)
- W_x : Torsion section modulus
- W_y : Minimum section modulus about local y-axis
- W_z : Minimum section modulus about local z-axis
- N_x : Axial force
- Q_y : Shear force in local y-direction
- Q_z : Shear force in local z-direction
- M_x : Torsional moment
- M_y : Bending moment about local y-axis
- M_z : Bending moment about local z-axis
- S_y, S_z : 1st area moment about y- and z- axis respectively
- t_p : profile thickness value depending on profile type

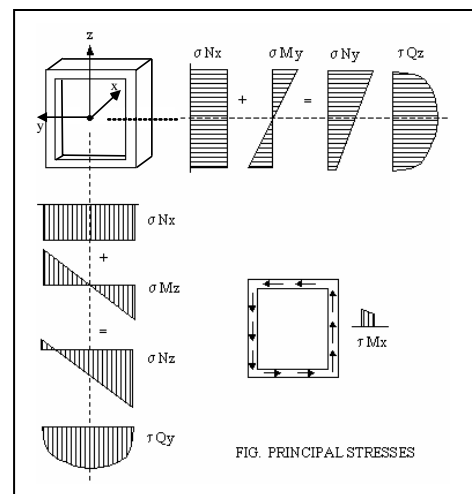

DODATAK E

Proračun i provjera strukturnih elemenata primjenom DNV 3D-Beam programskog alata

Naprezanje strukture dna uslijed dokovanja

Load case No 1 Opterećenje uslijed dokovanja

Effective Stress, values, sorted by SigEff in Descending order

Beam No.	σ_{eff} [N/mm ²]	Usage	x-pos [mm]	y-pos [mm]	z-pos [mm]	σ_{Nx} [N/mm ²]	σ_{My} [N/mm ²]	σ_{Mz} [N/mm ²]	τ_{Mx} [N/mm ²]	τ_{Qy} [N/mm ²]	τ_{Qz} [N/mm ²]
1	125	0,53	0	0	1015	14	38	0	0	0	66
4	125	0,53	0	0	1015	14	38	0	0	0	66
3	80	0,34	2407,5	0	912,6	13	33	0	0	0	38
2	80	0,34	2407,5	0	912,6	13	33	0	0	0	38

Abbreviations

σ_{eff} : Effective stress according to von Mises, $\sigma_{eff} = \sqrt{(\sigma_{Nx} + \sigma_{My} + \sigma_{Mz})^2 + 3(|\tau_{Mx}| + |\tau_{Qy} + \tau_{Qz}|)^2}$

Usage: Usage factor = $\sigma_{eff} / (\sigma_{yield} / \gamma_M)$

σ_{yield} = specified yield stress

γ_M = material factor = 1.0 unless otherwise specified

Position of stress point where σ_{eff} is computed:

x-pos: Distance from start of beam

y-pos: y-coordinate on profile

z-pos: z-coordinate on profile

Stresses at the stress point:

σ_{Nx} : Axial stress

σ_{My} : Bending stress about local y-axis

σ_{Mz} : Bending stress about local z-axis

τ_{Mx} : Torsional stress

τ_{Qy} : Shear stress in local y-direction

τ_{Qz} : Shear stress in local z-direction

