

Shema Termoelektrane u računalnom paketu "Epsilon professional"

Bobanac, Lovro

Supplement / Prilog

Publication year / Godina izdavanja: **2022**

Permanent link / Trajna poveznica: <https://um.nsk.hr/um:nbn:hr:190:895597>

Rights / Prava: [Attribution 4.0 International](#)/[Imenovanje 4.0 međunarodna](#)

Download date / Datum preuzimanja: **2024-08-12**



Repository / Repozitorij:

[Repository of the University of Rijeka, Faculty of Engineering](#)



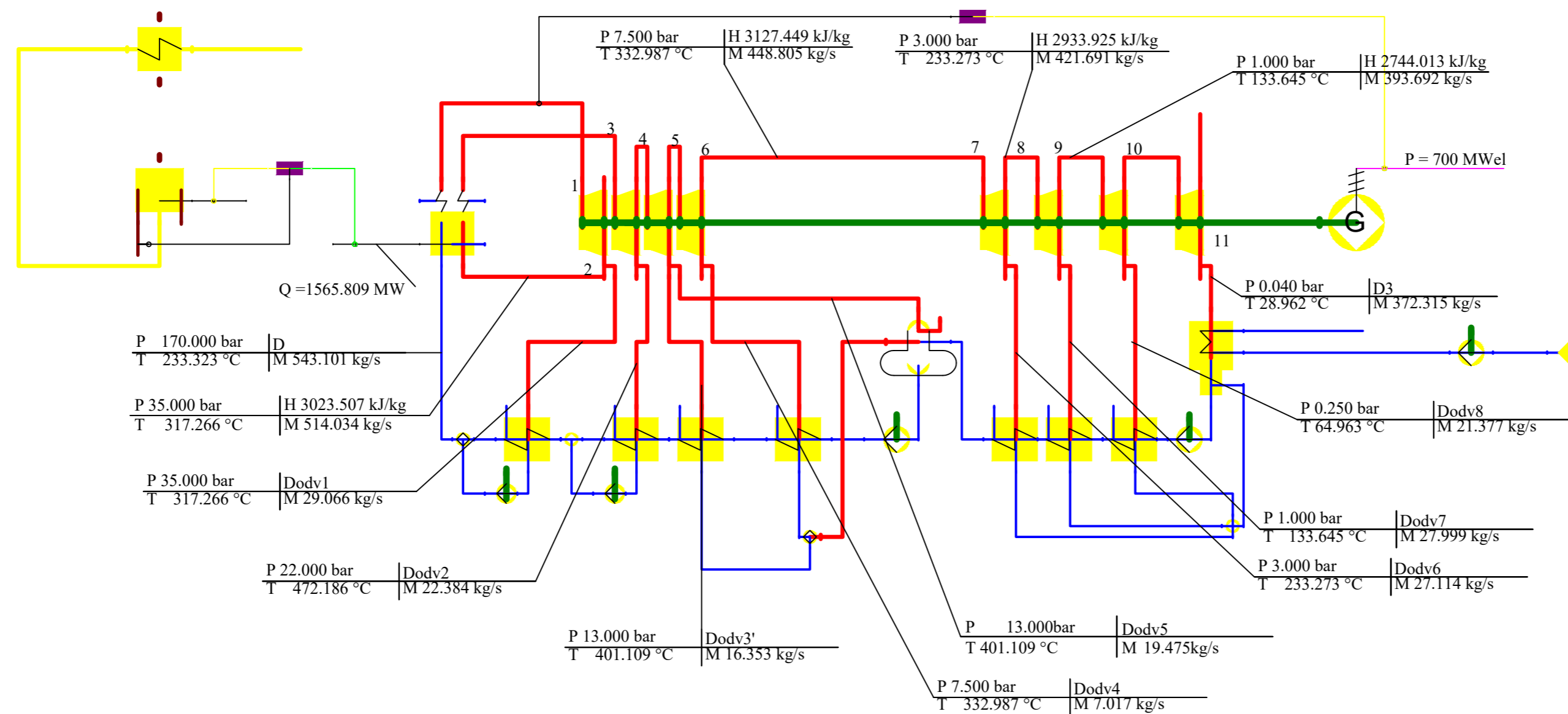

Specific enthalpy [kJ/kg]

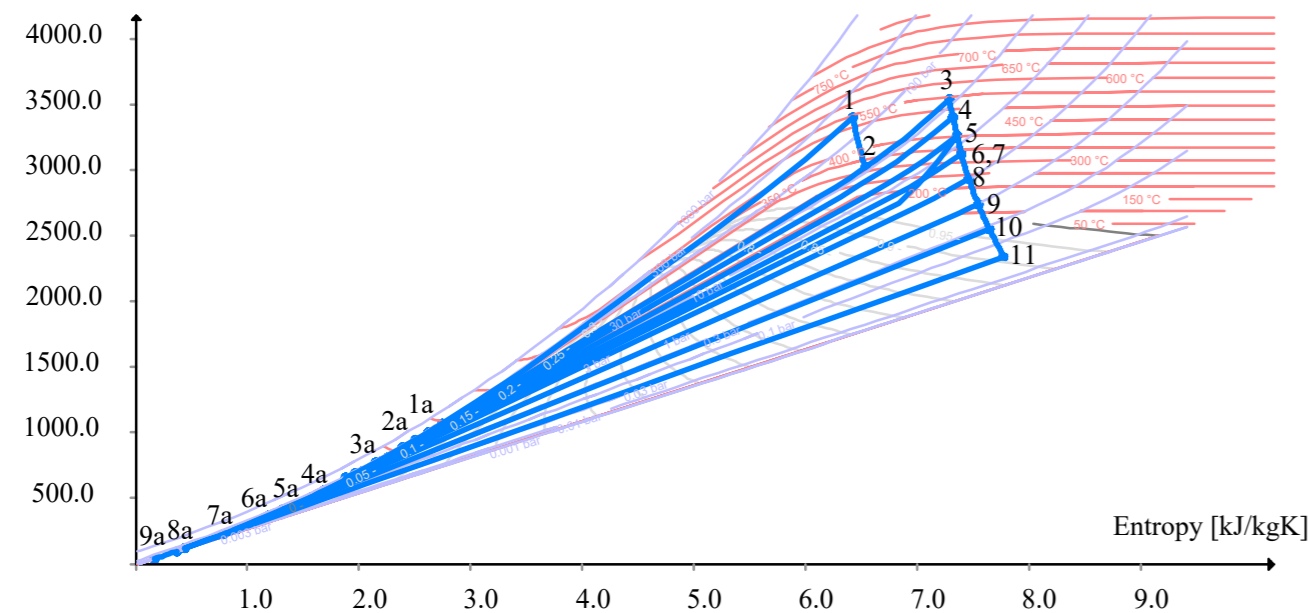

Temperature [°C]

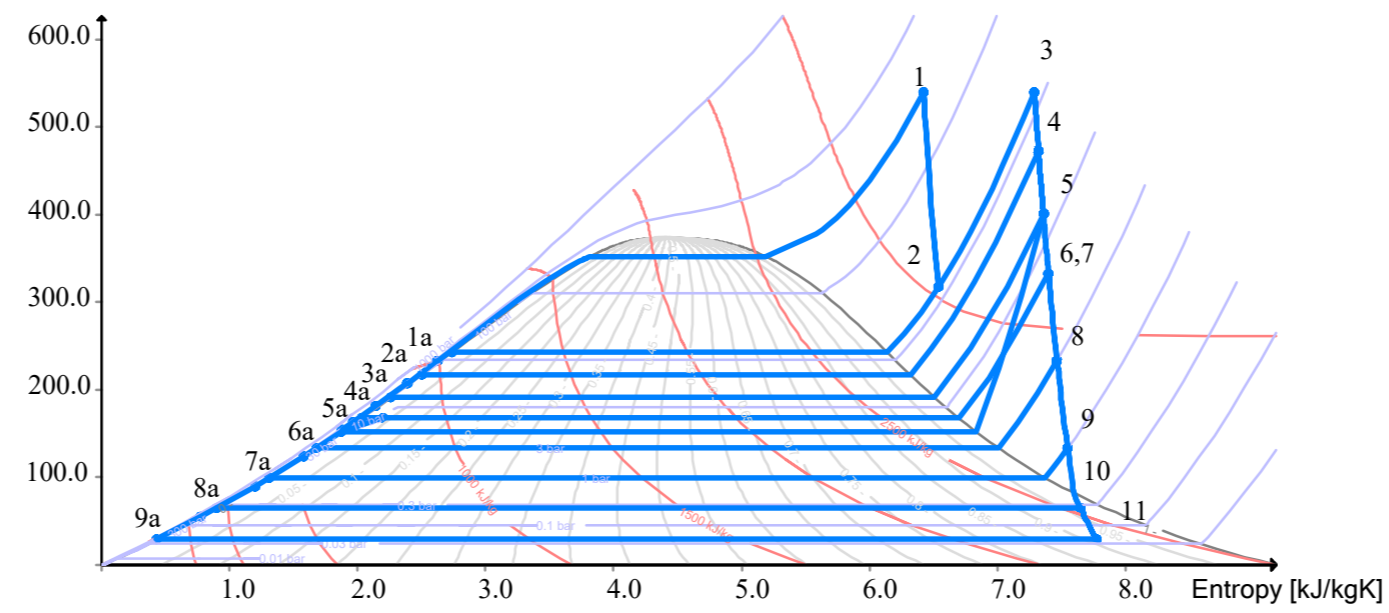

Tablica vrijednosti pare	
Maseni protok	Vrijednost[kg/s]
Dodv1	29,06
Dodv2	22,38
Dodv3'	16,35
Dodv4	7,01
Dodv5	19,48
Dodv6	27,11
Dodv7	27,99
Dodv8	21,37
D3	377,25

Diplomski rad	Nacrtao/la:	Datum:	Ime i matični broj:	Potpis:	Mjerilo:	
	Strojarstvo	Provjerio:	09.2022.	Lovro Bobanac 0035199304		List:
	Modul: Termotehnika	Odobrio:		Vladimir Glažar doc. prof. dr. sc.		Šk. god.: 21./22.
Tehnički fakultet Rijeka	Naziv dijela: Shema termoelektrane u Epsilonu, snage 700 MWel				Broj crteža: 2	