

# HIDROMEHANIČKI ASPEKTI PROJEKTA BRZOG MOTORNOG PLOVILA DUŽINE 10,5 M

---

Lukačić, Petra

Undergraduate thesis / Završni rad

2023

*Degree Grantor / Ustanova koja je dodijelila akademski / stručni stupanj:* **University of Rijeka, Faculty of Engineering / Sveučilište u Rijeci, Tehnički fakultet**

*Permanent link / Trajna poveznica:* <https://um.nsk.hr/um:nbn:hr:190:719029>

*Rights / Prava:* [Attribution 4.0 International](#)/[Imenovanje 4.0 međunarodna](#)

*Download date / Datum preuzimanja:* **2024-06-26**



*Repository / Repozitorij:*

[Repository of the University of Rijeka, Faculty of Engineering](#)



SVEUČILIŠTE U RIJECI

TEHNIČKI FAKULTET

Preddiplomski sveučilišni studij brodogradnje

Završni rad

**HIDROMEHANIČKI ASPEKTI PROJEKTA BRZOG  
MOTORNOG PLOVILA DUŽINE 10,5 m**

Rijeka, rujan 2023.

Petra Lukačić

0069089009

SVEUČILIŠTE U RIJECI

TEHNIČKI FAKULTET

Preddiplomski sveučilišni studij brodogradnje

Završni rad

**HIDROMEHANIČKI ASPEKTI PROJEKTA BRZOG  
MOTORNOG PLOVILA DUŽINE 10,5 m**

**Mentor: izv. prof. dr. sc. Anton Turk**

**Komentor: prof. dr. sc. Roko Dejhalla**

Rijeka, rujan 2023.

Petra Lukačić

0069089009

Rijeka, 14. ožujka 2023.

Zavod: **Zavod za brodogradnju i inženjerstvo morske tehnologije**  
Predmet: **Plovnost i stabilitet broda**  
Grana: **2.02.02 hidromehanika plovnih i pučinskih objekata**

## ZADATAK ZA ZAVRŠNI RAD

Pristupnik: **Petra Lukačić (0069089009)**  
Studij: Sveučilišni prijediplomski studij brodogradnje

Zadatak: **HIDROMEHANIČKI ASPEKTI PROJEKTA BRZOG MOTORNOG PLOVILA  
DUŽINE 10,5 M / HYDROMECHANICAL ASPECTS OF A FAST MOTOR  
VESSEL DESIGN WITH THE LENGTH OF 10.5 M**

### Opis zadatka:

Za odabrano brzo motorno plovilo potrebno je:

- Odabrati prikladnu formu trupa,
  - Izraditi model plovila u prikladnom programskom paketu,
  - Odrediti hidrostatičke značajke plovila,
  - Izraditi proračun stabiliteta prema EN ISO 12217:2017,
  - Odrediti hidrodinamičke značajke trupa na mirnoj vodi za jedno odabrano stanje opterećenja.
- Rezultate prikazati tablično i grafički.

Rad mora biti napisan prema Uputama za pisanje diplomskih / završnih radova koje su objavljene na mrežnim stranicama studija.

*Petra Lukačić*  
Zadatak uručen pristupniku: 20. ožujka 2023.  
Rok za predaju rada: 6. srpnja 2023.

Mentor:



Izv. prof. dr. sc. Anton Turk



Prof. dr. sc. Roko Dejhalla (komentor)

Predsjednik povjerenstva za  
završni ispit:



Prof. dr. sc. Roko Dejhalla

## Izjava

Sukladno čl. 9 *Pravilnika o završnom radu, završnom ispitu i završetku sveučilišnih prijediplomskih studija* izjavljujem da sam samostalno izradila rad pod naslovom *Hidromehanički aspekti projekta brzog motornog plovila dužine 10,5 m*, konzultirajući se s mentorom i komentorom te primjenjujući znanja stečena tijekom prijediplomskog studija.

Rijeka, rujan 2023.

---

Petra Lukačić

## ***Zahvala***

*Zahvaljujem mentoru, izv. prof. dr. sc. Antonu Turku i komentoru prof. dr. sc. Roku Dejhalli na savjetima i znanju prenesenom tijekom izrade ovog rada.*

*Zahvaljujem roditeljima i sestri na podršci, strpljenju i toplini, na tomu što su me poticali kada je bilo potrebno i što su mi oslonac.*

*Hvala i svim prijateljima i kolegama koji su svojim prisustvom oblikovali i uljepšali moje dosadašnje iskustvo studiranja.*

## Sadržaj

1. Uvod.....	1
2. Izrada modela plovila.....	2
2.1 Opis plovila.....	2
2.2 Proces izrade modela.....	3
3. Hidrostatske značajke plovila.....	7
4. Proračun stabiliteta prema EN ISO 12217:2017.....	9
4.1 Procjena težišta plovila.....	9
4.2 Poluga stabiliteta.....	11
4.3 Rezultati proračuna.....	12
5. Određivanje hidrodinamičkih značajki trupa.....	14
5.1 Metoda.....	14
5.1.1 Bezdimenzijski koeficijent uzgona.....	14
5.1.2 Faktor oplakivanja (engl. <i>Wetting Factor</i> ).....	15
5.1.3 Bezdimenzijski koeficijent momenta posrtanja.....	16
5.1.4 Srednji omjer oplakivane duljine i širine (engl. Running mean wetted length-beam ratio).....	16
5.1.5 Određivanje gaza i trima.....	16
5.2 Proračun.....	17
5.2.1 Ulazni podatci.....	17
5.2.2 Izračun koeficijenata i ostalih veličina.....	18
6. Zaključak.....	28
<b>Literatura.....</b>	<b>29</b>
Popis oznaka i kratica.....	30
Popis slika i tablica.....	32
Sažetak.....	34
Prilozi.....	35

## 1. Uvod

Gliserske forme vrlo su popularne među plovilima različitih namjena, od zabave do radnih i patrolnih brodova. Njihova posebnost u odnosu na deplasmanske i poludeplasmanske forme je u tomu što se, osim hidrostatskog uzgona, razvija i hidrodinamički uzgon, zbog kojeg prelaze iz deplasmanskog u gliserski režim plovidbe postižući tako često vrlo velike brzine.

Zbog navedenog načina stvaranja uzgona, problem proračuna otpora raslojava se u odnosu na proračune otpora deplasmanskih formi. Zato se stvorila potreba za razvojem novih metoda procjene otpora i ostalih hidromehaničkih značajki, kao što su dinamički kut trima i gaz pri gliserskom režimu plovidbe. Jedna od značajnih metoda procjene navedenih značajki je ona autora Richarda A. Roycea, koja je opisana i primijenjena u ovom radu. S obzirom na to da se njen razvoj ne temelji na empirijskim, već na fizikalnim izrazima, ona se može smatrati poprilično preciznom i točnom. Proračun je izvršen za raspon brzina kako bi se prikazalo ponašanje zadane forme pri promjeni brzine.

Uz hidrodinamička svojstva, ovaj rad analizira i stabilitet zadanog gliserskog plovila, kao jedno od osnovnih sigurnosnih aspekata svakog plovila. Procjena stabiliteta napravljena je prema normi EN ISO 12217:2017, uz pomoć popratnih alata, jedan od kojih je *Rhinoceros 7*, koji je korišten za izradu digitalnog modela same forme, te dodatka *Orca 3D* za dobivanje podataka o hidrostatičkim značajkama plovila.



## 2. Izrada modela plovila

### 2.1 Opis plovila

Plovilo čijim se hidromehaničkim značajkama ovaj rad bavi ima glisersku formu. U Tablici 2.1 nalaze se relevantni podaci koji opisuju glavne geometrijske karakteristike zadanog plovila. Na Slici 2.1 prikazane su glavne izmjere.

Tablica 2.1 Glavne izmjere zadanog plovila

$L_{OA}$	10,4 m
$B_{OA}$	2,9 m
$D$	1,8 m
$T$ (preliminarno)	0,7 m
$\Delta$ (puno opterećenje)	6291 kg
$\beta$	24,5°

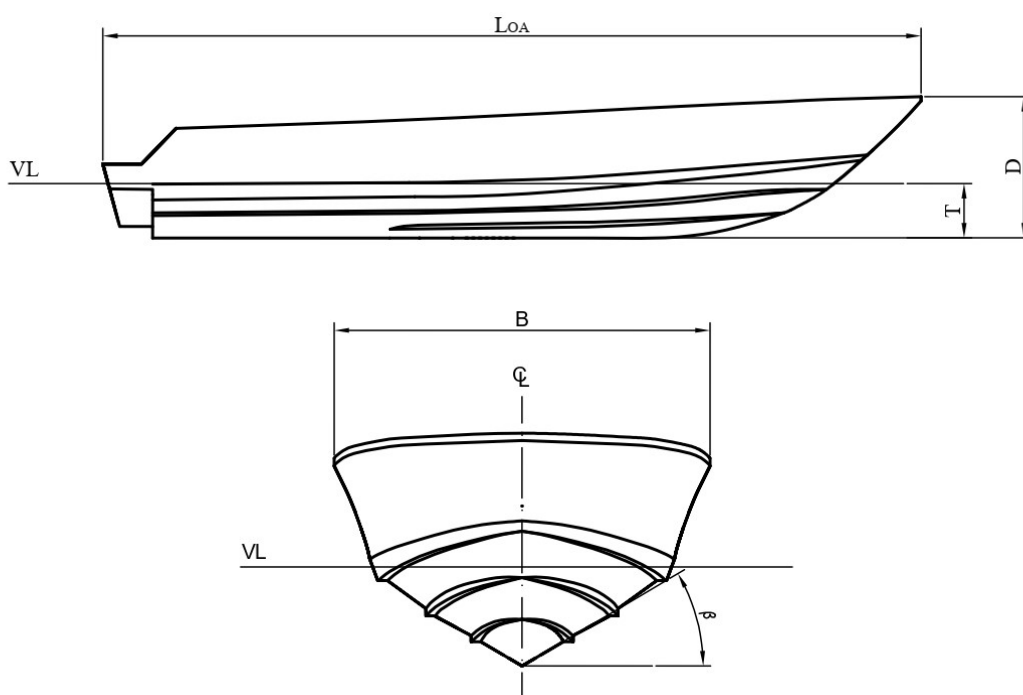

Slika 2.1 Skica glavnih izmjera plovila

## 2.2 Proces izrade modela

Model zadanog plovila izrađen je u programskom paketu *Rhinoceros 7*, te korištenjem *AutoCAD*-a kao pomoćnog programa.

Odabrana forma modelirana je na temelju nacrt linija iz perspektiva plovila. Nacrt linija plovila, generiran iz modela na kraju procesa modeliranja, nalazi se u Prilogu 1. Prikaz linija nalazi se na Slici 2.2.

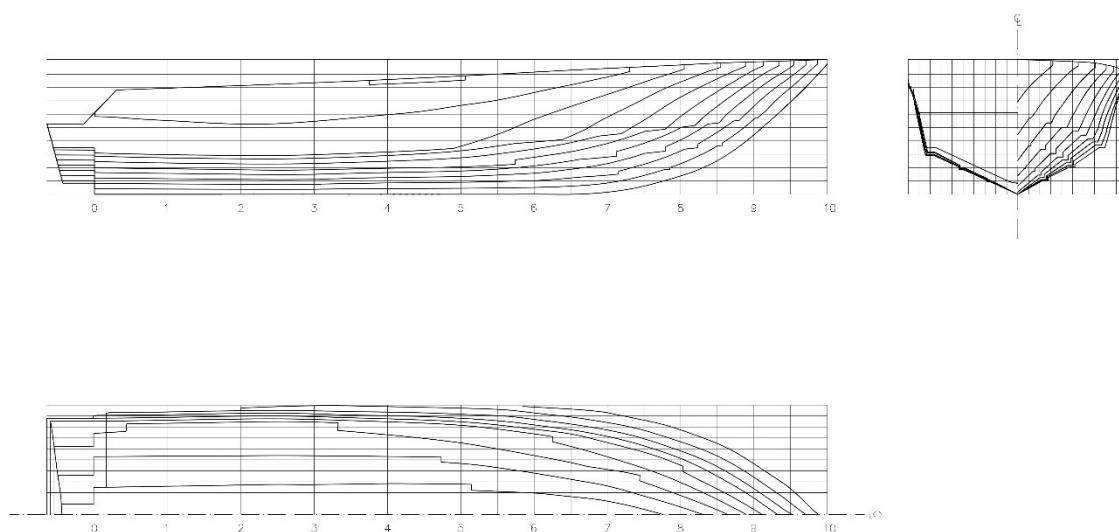

*Slika 2.2 Nacrt linija plovila*

Za početak, linije plovila prenesene su iz slikovne datoteke predloška u datoteku podržanu u navedenim programima jednostavnim procesom precrtavanja, koristeći *AutoCAD*. Ta je datoteka zatim prenesena u *Rhinoceros 7* kako bi se započelo s trodimenzionalnim modeliranjem.

U *Rhinocerosu* je bilo potrebno definirati mrežu rebara, što je napravljeno prema razmaku rebara zadanom u dobivenom predlošku. Istovremeno je definirana i osnovica plovila kao polazna točka za mjerenje visina na koje se postavljaju linije rebara. Unesene linije rebara zatim su premještane na odgovarajuću poziciju koristeći izrađenu mrežu (Slika 2.3).

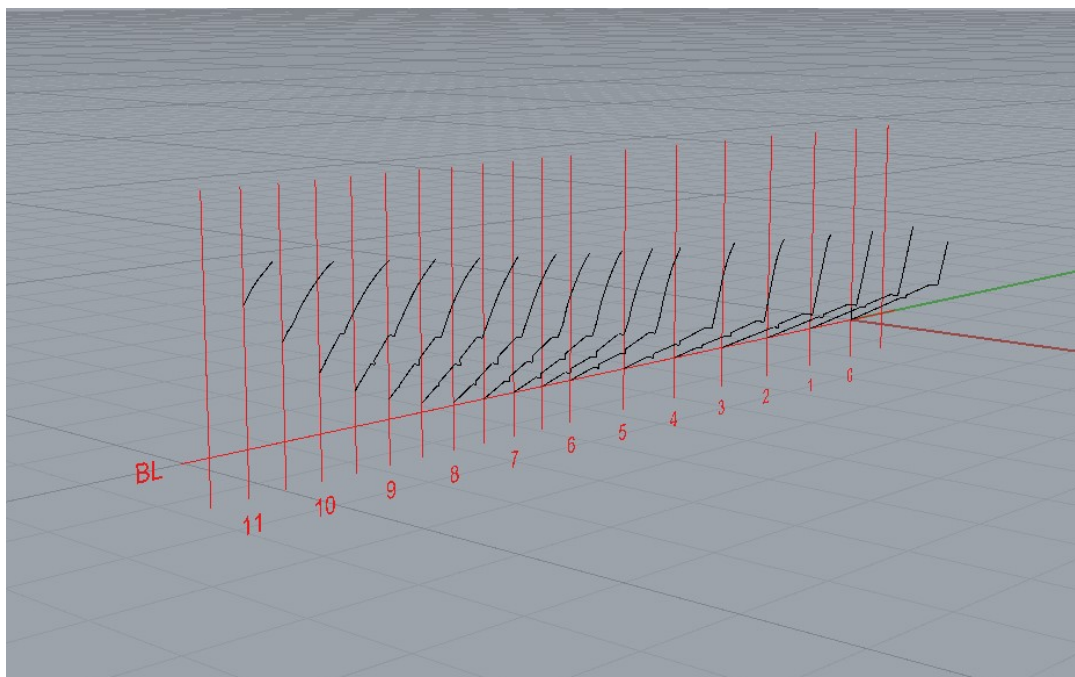

*Slika 2.3 Mreža s linijama rebara na odgovarajućim pozicijama*

Nakon toga bilo je potrebno izraditi liniju kobilice i linije zgibova, što je učinjeno spajanjem odgovarajućih točaka na rebrima, naredbom *InterpCrv*. S obzirom na to da su linije rebara dobivene precrtavanjem s predloška, linije kobilice i zgibova nisu bile glatke, pa je bilo potrebno izgladiti ih premještanjem kontrolnih točaka i pregledavanjem krivulja u različitim pogledima, te korištenjem alata za analizu krivulja (Slika 2.4).

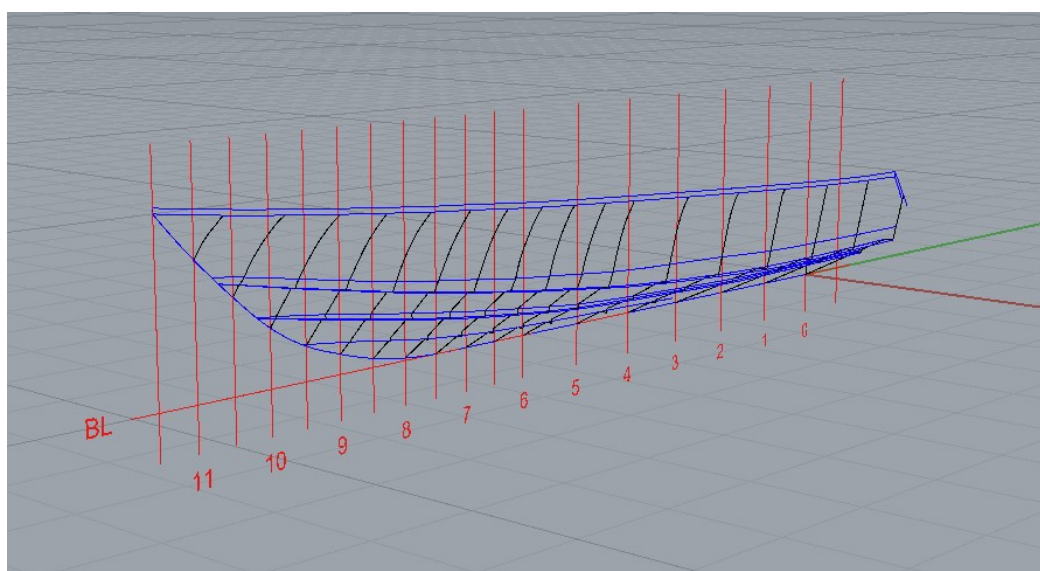

*Slika 2.4 Linije zgibova, kobilice i razme (plavo)*

Za izradu ploha plovila, bilo je potrebno razdvojiti linije rebara na manje dijelove koji pripadaju zasebnim ploham a te ih redefinirati kako bi imale jednak broj kontrolnih točaka, za što je korištena naredba *Rebuild*. Plohe su izrađene naredbom *Surface from network of curves* (Slika 2.4). Krmeno zrcalo izrađeno je naredbom *PlanarSrf* nakon presijecanja trupa plovila ravninom pod zadanim kutom (Slika 2.6).

Paluba je modelirana definiranjem kontura na gornjem i donjem kraju te njihovim spajanjem korištenjem naredbe *Sweep2*, Slike 2.7 i 2.8.

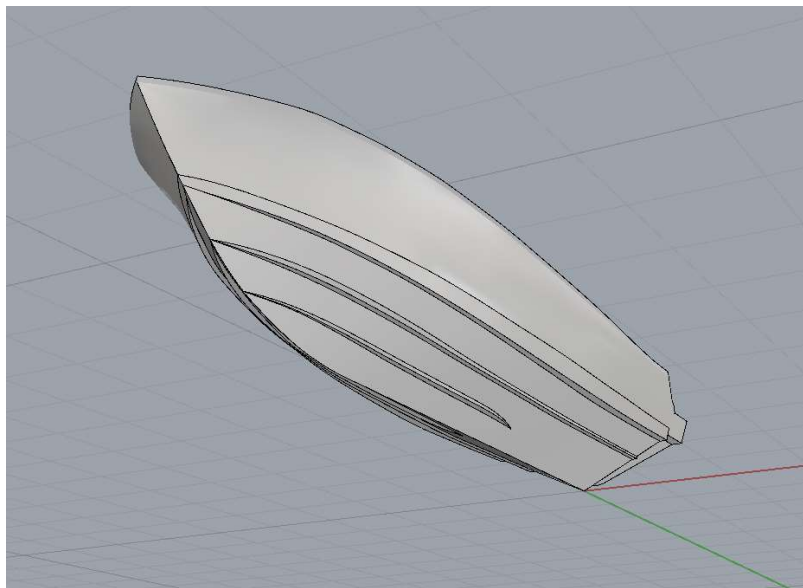

*Slika 2.5 Forma plovila*

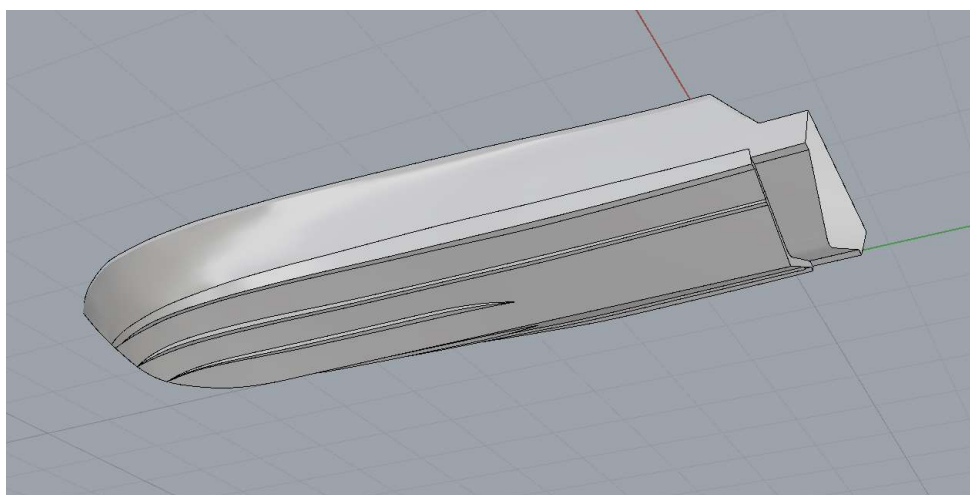

*Slika 2.6 Prikaz forme i krmelog zrcala*

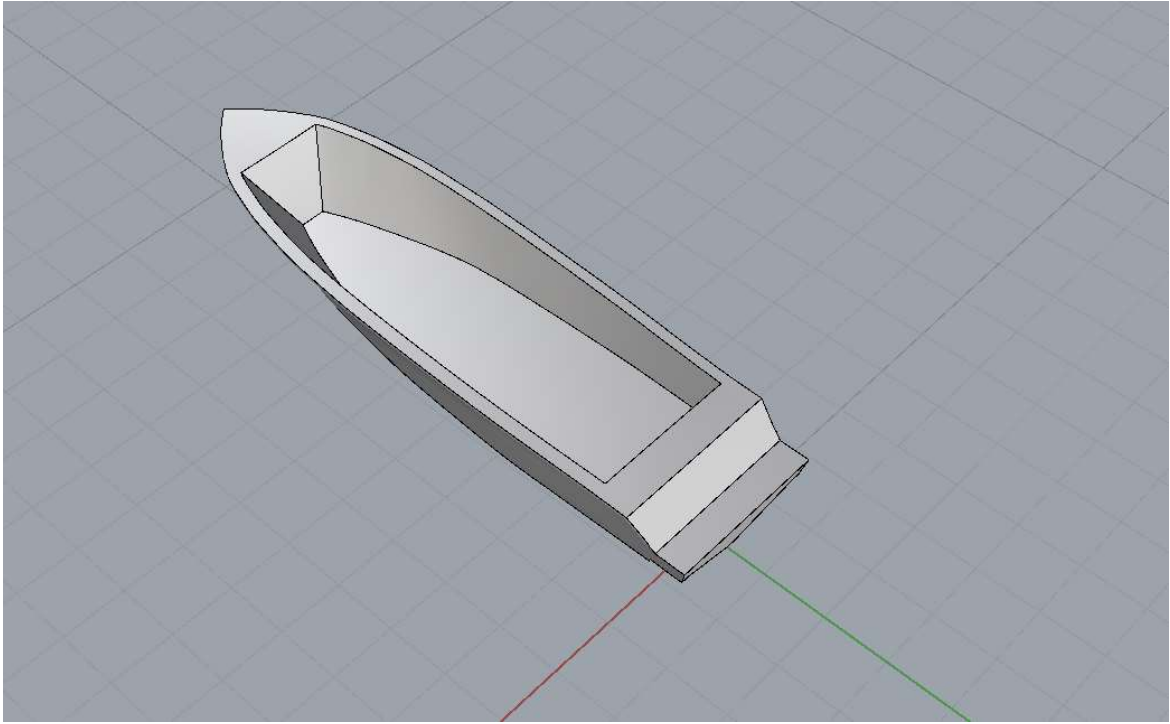

*Slika 2.7 Prikaz palube*

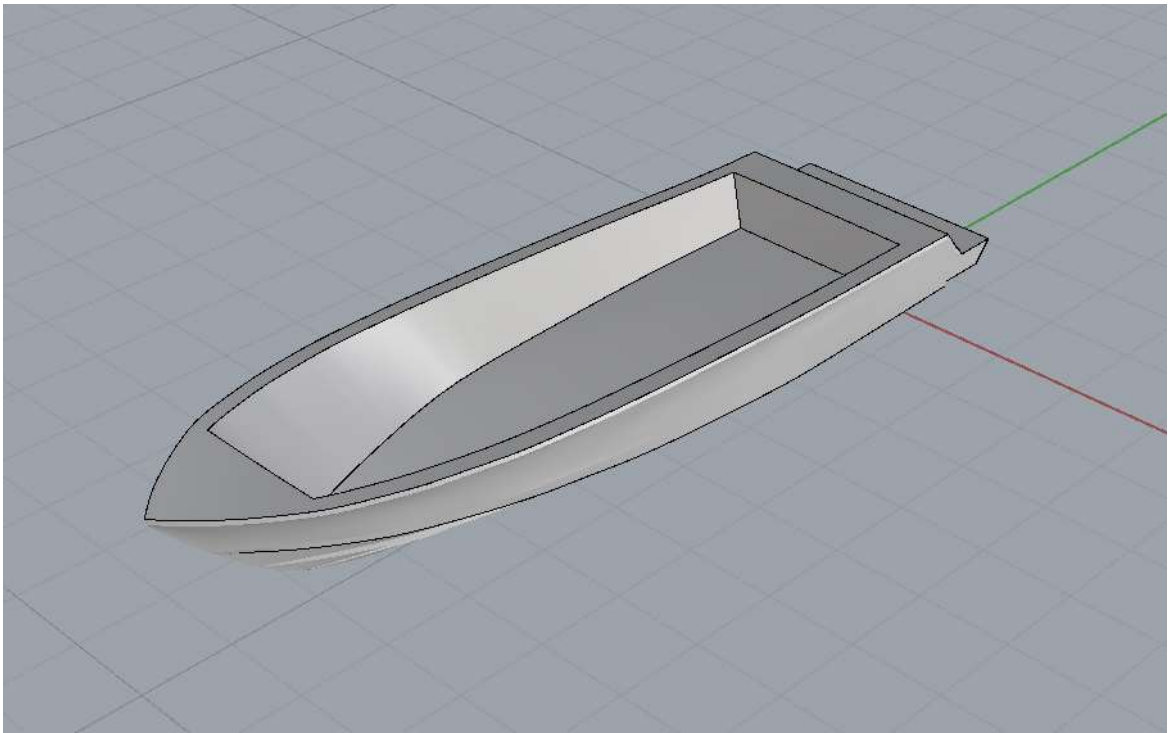

*Slika 2.8 Prikaz palube*

Sve su izrađene plohe spojene u jedinstvenu cjelinu, te je provjerena „vodonepropusnost“ forme.

### 3. Hidrostatske značajke plovila

Hidrostatske značajke zadanog plovila opisane su dijagramskim listom, Slika 3.1. Na Slici 3.2 prikazana je ovisnost koeficijenta forme o gazu.

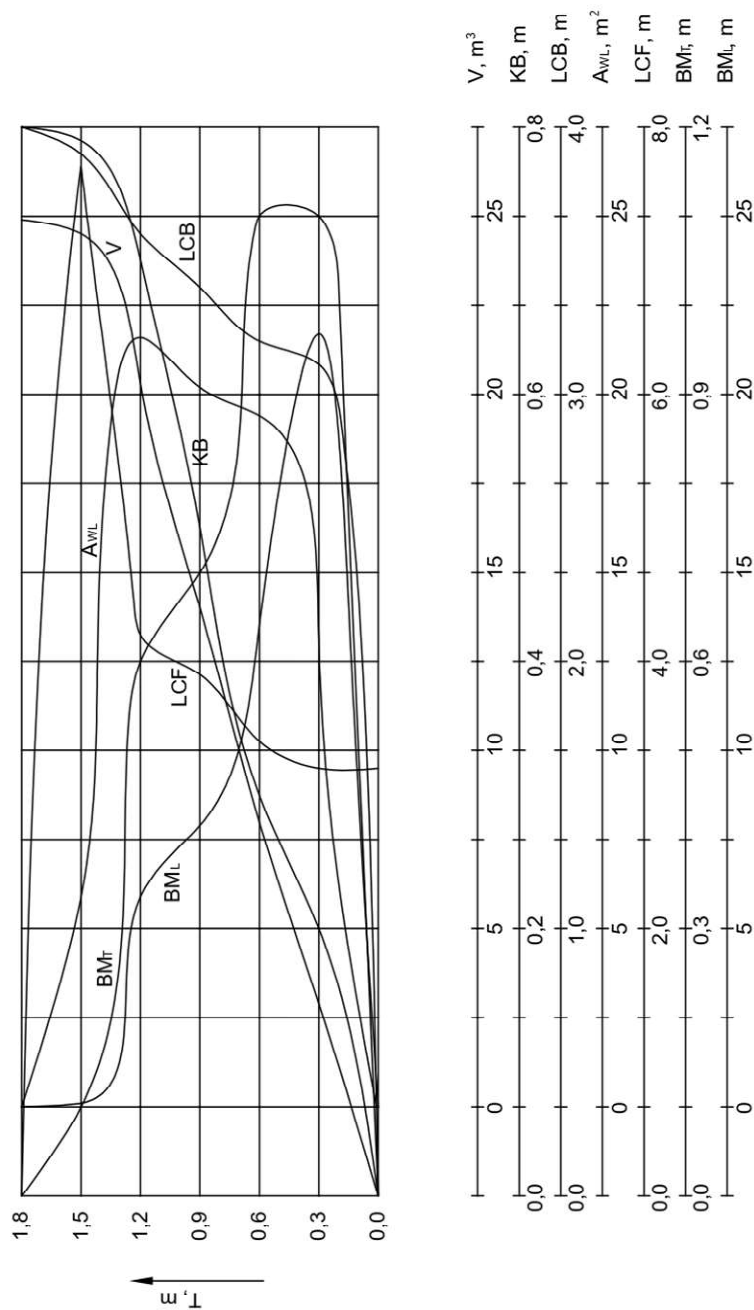

Slika 3.1 Dijagramski list

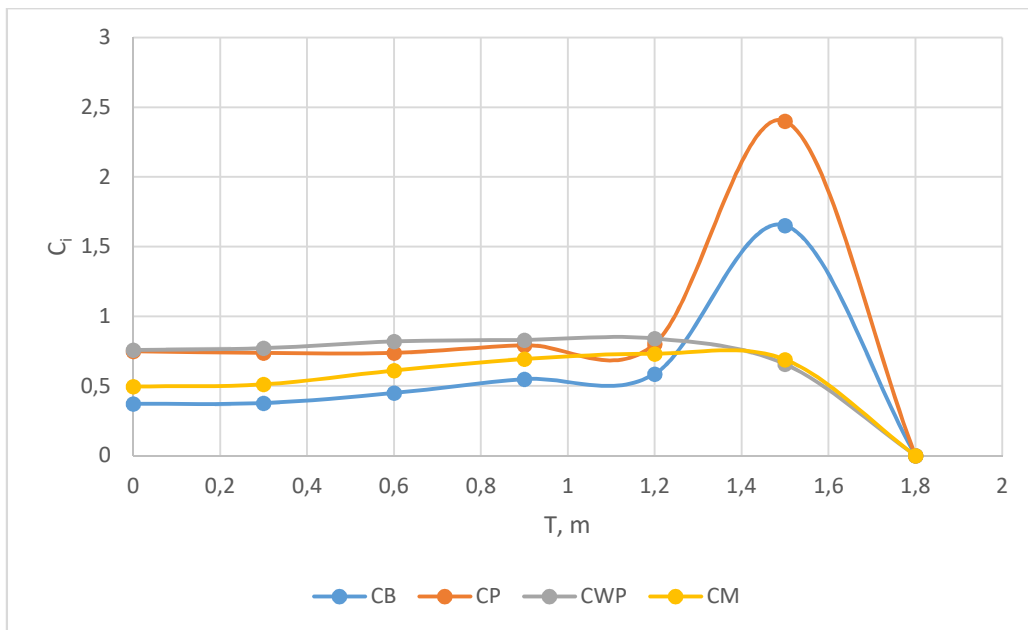

*Slika 3.2 Dijagram ovisnosti koeficijenta forme o gazu*

#### 4. Proračun stabilneta prema EN ISO 12217:2017

Za provjeru karakteristika stabilneta plovila prema EN ISO 12217:2017 korišten je tablični kalkulator preuzet sa službenih stranica *International Marine Certification Institute* [1]. Popunjene tablice nalaze se u Prilogu 2.

##### 4.1 Procjena težišta plovila

U tablicama 4.1, 4.3 i 4.5 prikazane su raspodjele masa i izračun momenata masa za tri različita stanja opterećenja definirana prema normi ISO 12217, a u tablicama 4.2, 4.4 i 4.6 prikazane su koordinate težišta masa sustava za ista stanja opterećenja.

*Tablica 4.1 Raspodjela masa za stanje punog opterećenja (engl. Loaded Displacement Condition)*

	<b>m<sub>i</sub>, kg</b>	<b>x<sub>i</sub>, m</b>	<b>y<sub>i</sub>, m</b>	<b>z<sub>i</sub>, m</b>	<b>m<sub>i</sub>*x<sub>i</sub>, kg*m</b>	<b>m<sub>i</sub>*y<sub>i</sub>, kg*m</b>	<b>m<sub>i</sub>*z<sub>i</sub>, kg*m</b>
<b><u>Struktura</u></b>							
<b>Trup, paluba, konzola</b>	2705,0	3,9	0,0	0,7	10519,7	0,0	1893,5
<b>Σ</b>	2705,0				10519,7	0,0	1893,5
<b><u>Oprema</u></b>							
<b>Izvanbrodski motor</b>	1560,0	0,5	0,0	1,0	737,9	0,0	1560,0
<b>Tank goriva</b>	1117,8	3,0	0,0	0,4	3375,8	0,0	391,2
<b>Tank vode</b>	166,1	1,4	0,0	0,4	240,5	0,0	58,1
<b>Razna oprema (bitve, sidro, lanac)</b>	143,0	5,0	0,0	0,6	715,0	0,0	90,1
<b>Osobne stvari</b>	150,0	3,5	0,0	0,7	525,0	0,0	111,8
<b>Provijant</b>	0,0		0,0		0,0	0,0	0,0
<b>Σ</b>	3136,9				5594,1	0,0	2211,2
<b><u>Osobe</u></b>							
<b>#1</b>	75,0	0,9	-0,5	1,6	245,2	-37,5	122,6
<b>#2</b>	75,0	0,9	0,5	1,6	245,2	37,5	122,6
<b>#3</b>	75,0	3,3	-0,5	1,6	65,2	-37,5	122,6
<b>#4</b>	75,0	3,3	0,5	1,6	65,2	37,5	122,6
<b>#5</b>	75,0	4,9	-0,5	1,6	365,2	-37,5	122,6
<b>#6</b>	75,0	4,9	0,5	1,6	365,2	37,5	122,6
<b>Σ</b>	450,0				1351,1	0,0	735,8
<b><u>Ukupno:</u></b>	6291,9				17464,9	0,0	4840,5



<b>Istisnina:</b>	6291,9					
<b>Gaz:</b>	0,711 m					

Tablica 4.2 Koordinate težišta za stanje punog opterećenja (engl. Loaded Displacement Condition)

<b>LCG, m</b>	2,776
<b>TCG, m</b>	0,000
<b>VCG, m</b>	0,769

Tablica 4.3 Raspodjela masa za minimalno radno stanje (engl. Minimum Operating Condition)

	<b>m<sub>i</sub>, kg</b>	<b>x<sub>i</sub>, m</b>	<b>y<sub>i</sub>, m</b>	<b>z<sub>i</sub>, m</b>	<b>m<sub>i</sub>*x<sub>i</sub>, kg*m</b>	<b>m<sub>i</sub>*y<sub>i</sub>, kg*m</b>	<b>m<sub>i</sub>*z<sub>i</sub>, kg*m</b>
<b><u>Struktura</u></b>							
<b>Trup, paluba, konzola</b>	2705,0	3,9	0,0	0,7	10519,7	0,0	1893,5
<b>Σ</b>	2705,0				10519,7	0,0	1893,5
<b><u>Oprema</u></b>							
<b>Izvanbrodski motor</b>	1560,0	0,5	0,0	1,0	737,9	0,0	1560,0
<b>Tank goriva</b>			0,0		0,0	0,0	0,0
<b>Tank vode</b>			0,0		0,0	0,0	0,0
<b>Razna oprema</b>	80,0	5,0	0,0	0,6	400,0	0,0	50,4
<b>Osobne stvari</b>			0,0		0,0	0,0	0,0
<b>Σ</b>	1640,0				1137,9	0,0	1610,4
<b><u>Osobe</u></b>							
<b>#1</b>	75,0	3,3	-0,5	1,6	245,2	0,0	122,6
<b>#2</b>	75,0	3,3	0,5	1,6	245,2	0,0	122,6
<b>Σ</b>	150,0				490,4	0,0	245,3
<b><u>Ukupno:</u></b>	4495,0				12148,0	0,0	3749,2
<b><u>Istisnina:</u></b>	4495,0						
<b><u>Gaz:</u></b>	0,402 m						

Tablica 4.4 Koordinate težišta za minimalno radno stanje (engl. Minimum Operating Condition)

<b>LCG, m</b>	2,703
<b>TCG, m</b>	0,000
<b>VCG, m</b>	0,834

Tablica 4.5 Raspodjela masa za stanje opterećenja plovila u dolasku (engl. Loaded Arrival Condition)

	<b>m<sub>i</sub>, kg</b>	<b>x<sub>i</sub>, m</b>	<b>y<sub>i</sub>, m</b>	<b>z<sub>i</sub>, m</b>	<b>m<sub>i</sub>*x<sub>i</sub>, kg*m</b>	<b>m<sub>i</sub>*y<sub>i</sub>, kg*m</b>	<b>m<sub>i</sub>*z<sub>i</sub>, kg*m</b>
<b><u>Struktura</u></b>							
<b>Trup, paluba, konzola</b>	2705,0	3,9	0,0	0,7	10519,7	0,0	1893,5
<b>Σ</b>	2705,0				10519,7	0,0	1893,5
<b><u>Oprema</u></b>							
<b>Izvanbrodski motor</b>	1560,0	0,5	0,0	1,0	737,9	0,0	1560,0
<b>Tank goriva</b>	167,7	3,0	0,0	0,5	506,4	0,0	83,8
<b>Tank vode</b>	24,9	1,4	0,0	0,5	36,1	0,0	12,5
<b>Razna oprema (bitve, sidro, lanac)</b>	143,0	5,0	0,0	0,6	715,0	0,0	90,1
<b>Osobne stvari</b>	141,3	3,5	0,0	0,7	494,6	0,0	105,3
<b>Provijant</b>	0,0		0,0		0,0	0,0	0,0
<b>Σ</b>	2036,9				2489,9	0,0	1851,7
<b><u>Osobe</u></b>							
<b>#1</b>	75,0	0,9	-0,5	1,6	245,2	-37,5	122,6
<b>#2</b>	75,0	0,9	0,5	1,6	245,2	37,5	122,6
<b>#3</b>	75,0	3,3	-0,5	1,6	65,2	-37,5	122,6
<b>#4</b>	75,0	3,3	0,5	1,6	65,2	37,5	122,6
<b>#5</b>	75,0	4,9	-0,5	1,6	365,2	-37,5	122,6
<b>#6</b>	75,0	4,9	0,5	1,6	365,2	37,5	122,6
<b>Σ</b>	450,0				1351,1	0,0	735,8
<b><u>Ukupno:</u></b>	5191,9				14360,7	0,0	4480,9
<b><u>Istisnina:</u></b>	5191,9						
<b><u>Gaz:</u></b>	0,442 m						

Tablica 4.6 Koordinate težišta za stanje opterećenja plovila u dolasku (engl. Loaded Arrival Condition)

<b>LCG, m</b>	2,766
<b>TCG, m</b>	0,000
<b>VCG, m</b>	0,863

## 4.2 Poluga stabiliteta

Poluge stabiliteta zadane forme za stanje punog opterećenja i za minimalno radno stanje dobivene su primjenom dodatka za unutar programskog paketa *Rhinoceros 7*, *Orca 3D*, te su prikazane na slikama 4.1 i 4.2.

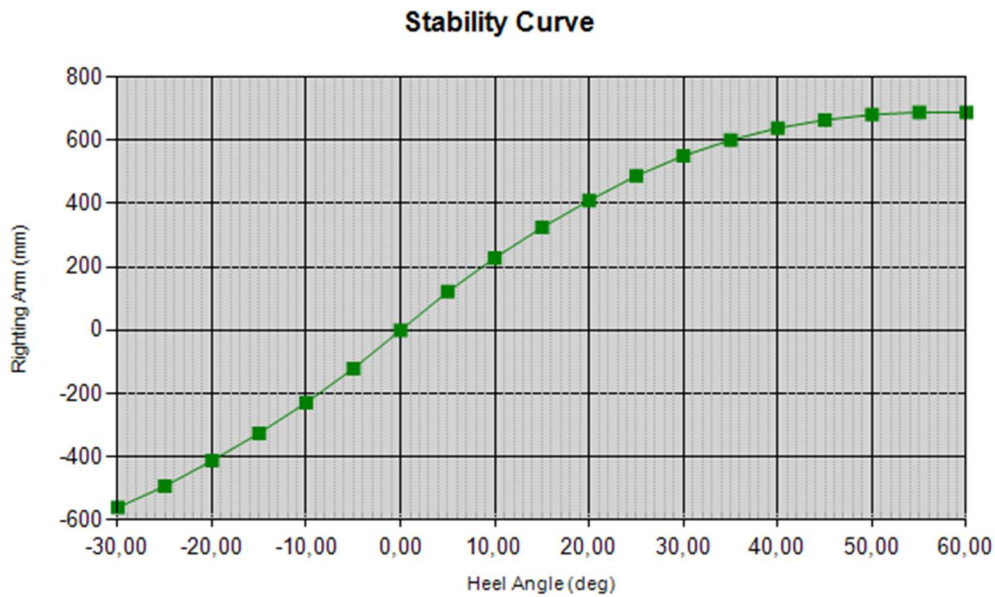

Slika 4.1 Poluga stabiliteta za stanje punog opterećenja (engl. Loaded Displacement Condition)

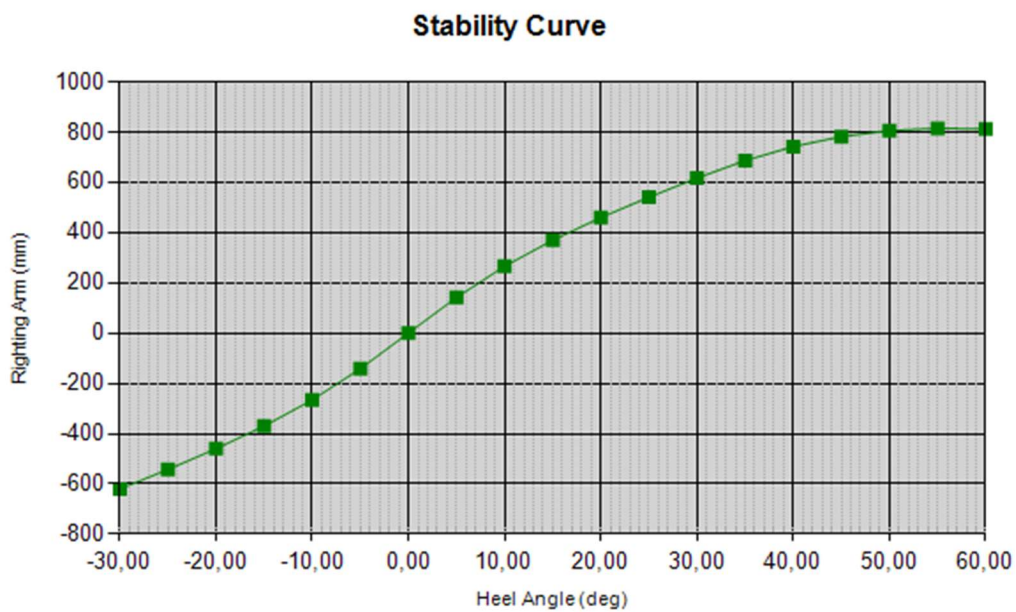

Slika 4.2 Poluga stabiliteta za minimalno radno stanje (engl. Minimum Operating Condition)

### 4.3 Rezultati proračuna

Proračun je za zadano plovilo izvršen za projektnu kategoriju B.

Tijek proračuna prema navedenom tabličnom kalkulatoru za početak zahtijeva unos masa za različita stanja opterećenja. Nakon toga prelazi se na procjenu stabiliteta za dva stanja opterećenja

(stanje punog opterećenja i minimalno radno stanje). To je učinjeno unošenjem veličina poluge stabiliteta za niz kutova nagiba. U ovom slučaju, zadano plovilo zadovoljava kriterije stabiliteta.

Sljedeća stavka koja se ispituje je otpornost na vjetar i valove u pogledu stabiliteta, za što se zahtijevaju unosi veličina projiciranih bočnih površina nadvodnog dijela, kao i poluga između projiciranih bočnih površina nadvodnog i podvodnog dijela plovila za dva relevantna stanja opterećenja. Plovilo zadovoljava i ove kriterije.

U Prilogu 2 nalazi se popunjeni tablični kalkulator sa svim unesenim veličinama i potvrdom zadovoljavanja kriterija.

## 5. Određivanje hidrodinamičkih značajki trupa

Od hidrodinamičkih značajki plovila određen je ukupni otpor te dinamički trim golog trupa za područje brzina od 20 kn do 50 kn.

### 5.1 Metoda

Za određivanje hidrodinamičkih značajki zadanog trupa korištena je metoda „*A Rational Prismatic Hull Approach For Planing Hull Analysis*“ autora Richarda A. Roycea [2]. Ova metoda kombinira Vorusov proračun hidrodinamičkog uzgona s numeričkim pristupom određivanju hidrostatskog uzgona. Razdvajanje učinaka na hidrostatske i hidrodinamičke pojednostavljuje izračun, a te se dvije komponente kasnije superponiraju kako bi se došlo do veličina uzgona i momenta posrtanja iz kojih se može doći do veličina dinamičkog trima i sile ukupnog otpora.

Proces proračuna sastoji se od izračuna bezdimenzijskog koeficijenta uzgona, zatim izračuna bezdimenzijskog koeficijenta momenta posrtanja, te izračuna gaza i trima koji zadovoljavaju ravnotežu sila i momenata, za što se koristi grafički pristup. Na temelju tih podataka moguće je odrediti dolazi li pri zadanoj brzini do uranjanja zgiba, što uvelike utječe na veličinu otpora trenja. Iz veličine otpora naposljetku se izračunava potrebna snaga poriva.

#### 5.1.1 Bezdimenzijski koeficijent uzgona

Bezdimenzijski koeficijent uzgona računa se sljedećim izrazom:

$$Cl = \frac{\Delta}{\frac{1}{2}\rho U^2 B^2} \quad (5.1)$$

Ovaj je koeficijent dobiven superpozicijom bezdimenzijskog koeficijenta hidrostatskog uzgona i bezdimenzijskog koeficijenta hidrodinamičkog uzgona.

Kako bi se odredio bezdimenzijski koeficijent hidrostatskog uzgona, potrebno je odrediti koeficijente uzgona presjeka jedinične duljine, koje je zatim potrebno integrirati po duljini vodne

linije. Sav se izračun izvodi bezdimenzijski, što se postiže dijeljenjem veličina s B, odnosno širinom trupa na zgibu. Dobiva se koeficijent:

$$CF_s = \int_0^{L_{wl}} \frac{f_s}{\frac{1}{2}\rho g B^2} dx \quad (5.2)$$

Ovaj koeficijent ovisi o gravitacijskom ubrzanju, za razliku od koeficijenta hidrodinamičkog uzgona. Kako bi se eliminirala navedena razlika, ovako dobiveni koeficijent hidrostatičkog uzgona dijeli se s modificiranim Froudeovim brojem, koji je definiran na sljedeći način:

$$C_V = \frac{U}{\sqrt{gB}} \quad (5.3)$$

Tako se dobiva bezdimenzijski koeficijent hidrostatskog uzgona:

$$Cl_s = \frac{F_s}{\frac{1}{2}\rho U^2 B^2} \quad (5.4)$$

Za izračun bezdimenzijskog koeficijenta hidrodinamičkog uzgona, koristi se Vorusova definicija koeficijenta uzgona presjeka jedinične duljine, koji je funkcija vremena. Taj je oblik dobiven prenašanjem trodimenzionalnog problema u dvodimenzionalni prostor, odnosno promatranjem poprečnih presjeka trupa koji u vremenu prolaze kroz zamišljenu fiksnu ravninu okomitu na brzinu plovila. Na taj je način geometrija trupa definirana kao funkcija vremena, a ne duljine kao što je uobičajeno.

Bezdimenzijski koeficijent hidrodinamičkog uzgona definiran je na sljedeći način:

$$Cl_d = \frac{F_d}{\frac{1}{2}U^2 B^2} = \frac{1}{2} \tan(\eta_5) CF_d \quad (5.5)$$

### 5.1.2 Faktor oplakivanja (engl. *Wetting Factor*)

Faktor oplakivanja opisuje visinu do koje se voda nakuplja uz trup pri glisiranju, a definiran je kao omjer visine oplakivane površine trupa i visine vodne linije u odnosu na osnovicu trupa.

Veličina ovog faktora ovisi o nagibu dna trupa u odnosu na horizontalnu ravninu, te je s njim obrnuto proporcionalna.

Faktor oplakivanja primjenjuje se pri određivanju trenutka u kojem počinje uranjanje zgiba te pri određivanju položaja početka mlaza.

### 5.1.3 Bezdimenzijski koeficijent momenta posrtanja

Ukupni moment posrtanja jednak je vektorskom zbroju hidrostatskog i hidrodinamičkog momenta posrtanja. Za izračun ovih komponenti koriste se slični principi kao za izračun koeficijenata uzgona.

Bezdimenzijski koeficijent momenta posrtanja definiran je na sljedeći način:

$$C_m = \frac{\Delta L_{CG}}{\frac{1}{2} U^2 B^3} \quad (5.6)$$

### 5.1.4 Srednji omjer oplakivane duljine i širine (engl. Running mean wetted length-beam ratio)

Srednji omjer oplakivane duljine i širine koristi se kao referentna duljina za izračun otpora trenja. Definiran je kao omjer srednje oplakivane duljine na kobilici i zgibu te širine oplakivanog dijela trupa:

$$\lambda(x) = \frac{(L_k - L_c)}{2B} \quad (5.7)$$

Tako je za područje neuronjenog zgiba ovaj omjer definiran kao:

$$\lambda = \frac{2T_a}{4 \tan(\eta_5)} \quad (5.8)$$

a za područje uronjenog zgiba definiran je kao:

$$\lambda = \frac{2T_a - \tau_c}{4 \tan(\eta_5)} \quad (5.9)$$

### 5.1.5 Određivanje gaza i trima

Veličine gaza i trima potrebne su za izračun nekih od prethodno navedenih veličina. Za njihovo određivanje u ovoj metodi koristi se grafički pristup, s obzirom na to da bi za rješavanje sustava jednadžbi koje opisuju problem bio potreban kompleksan iterativni postupak. Pristup se temelji na činjenici da traženi gaz i trim moraju istovremeno zadovoljavati ravnotežu sila i momenata. Sile

koje se pritom uzimaju u obzir su težina sustava, uzgon, otpor i poriv. Momenti ovih sila izražavaju se kao momenti oko točke sjecišta krmenog zrcala i kobilice. Pretpostavlja se da je sustav u statičkoj ravnoteži.

U svrhu rješavanja sustava jednadžbi sila i momenata, u [2] je razvijen niz dijagrama u koje se podatci unose u obliku krivulja, iz čijeg se sjecišta očitavaju gaz i trim koji zadovoljavaju navedene uvjete.

## 5.2 Proračun

U nastavku se nalazi prikaz proračuna hidrodinamičkih značajki plovila za stanje opterećenja plovila u dolasku (engl. *Loaded Arrival Condition*) i brzinu 50 čvorova za trup bez privjesaka.

Raspodjela masa i koordinate težišta za navedeno stanje krcanja opisani su u tablicama 4.5 i 4.6.

Proračun je izvršen u imperijalnom sustavu mjera radi podudaranja s izrazima iz Royceove metode [2].

### 5.2.1 Ulazni podatci

U Tablici 5.1 nalazi se popis ulaznih podataka u metričkom i imperijalnom sustavu.

*Tablica 5.1 Ulazni podatci za proračun*

Veličina	Simbol		
Deplasman	$\Delta$	5191,9 kg	11446,2 lbs
Uzdužni položaj težišta	$L_{CG}$	2,766 m	9,108 ft
Vertikalni položaj težišta	$V_{CG}$	0,863 m	2,831 ft
Širina na zgibu	$B$	2,445 m	8,022 ft
Visina osovine broskog vijka od osnovice	$h$	0,072 m	-0,236 ft
Nagib osovine	$\varepsilon$	0°	0°
Brzina	$U$	25,722 m/s	84,390 ft/s
Nagib dna	$\beta$	24,5°	24,5°
Omjer oplakivane površine	$Wf$	1,338	1,338



## 5.2.2 Izračun koeficijenata i ostalih veličina

Kvadrat modificiranog Froudeovog broja izračunat je na sljedeći način:

$$Cv^2 = \frac{U^2}{gB} = \frac{84,390^2}{32,2 \cdot 8,022} = 27,571 \quad (5.10)$$

Nakon toga, određen je bezdimenzijski koeficijent uzgona:

$$Cl = \frac{\Delta}{\frac{1}{2}\rho U^2 B^2} = \frac{11446,2}{\frac{1}{2} \cdot 1,940 \cdot 84,390^2 \cdot 8,022^2} = 0,026 \quad (5.11)$$

Tako je dobivena jednadžba pravca:

$$Cl_d = Cl - \frac{1}{Cv^2} CF_s = 0,026 - 0,036 \cdot CF_s \quad (5.12)$$

Taj je pravac ucrtan u odgovarajući dijagram koeficijenata uzgona, što je prikazano na Slici 4.1. Koordinate sjecišta navedenog pravca s linijama konstantnog trima navedene su u Tablici 5.2.  $T_a$  označava bezdimenzionalni gaz.

Tablica 5.2 Očitavanja s dijagrama koeficijenata uzgona

$\eta_5, ^\circ$	$T_a$
2,0	0,171
2,5	0,161
3,0	0,152

Nakon toga, određen je koeficijent ukupnog momenta posrtanja u odnosu na točku sjecišta krmenog zrcala i kobilice:

$$Cm = \frac{\Delta L_{CG}}{\frac{1}{2}U^2 B^3} = \frac{11446,2 \cdot 9,108}{\frac{1}{2} \cdot 84,390^2 \cdot 8,022^3} = 0,029 \quad (5.13)$$

Dobivena je sljedeća jednadžba pravca:

$$Cm_d = Cm - \frac{1}{Cv^2} CM_s = 0,029 - 0,036 \cdot CM_s \quad (5.14)$$

Taj je pravac ucrtan u odgovarajući dijagram koeficijenata momenta posrtanja. U isti dijagram unesen je i pravac (5.3), Slika 5.2, te su očitane sljedeće koordinate njihovog sjecišta:

$$\eta_5 = 2,688^\circ$$

$$T_a = 0,157$$

Veličine  $\tau_{max}$  i  $\tau_{cw}$  izračunate su na sljedeći način:

$$\tau_{max} = 2 \cdot T_a = 2 \cdot 0,157 = 0,314 \quad (5.15)$$

$$\tau_{cw} = \frac{\tan(\beta)}{Wf} = \frac{\tan(24,5^\circ)}{1,338} = 0,341 \quad (5.16)$$

Kako vrijedi  $\tau_{max} < \tau_{cw}$ , slijedi da ne dolazi do uranjanja zgiba.

Omjer oplakivane duljine i širine izračunat je kao:

$$\lambda = \frac{2T_a - \tau_c}{4 \tan(\eta_5)} = \frac{2 \cdot 0,157 - 0,341}{4 \tan(2,688^\circ)} = 1,531 \quad (5.17)$$

Za potrebe izračuna otpora trenja, određen je Reynoldsov broj:

$$Re = \frac{U\lambda B}{10^{-5}} = \frac{84,390 \cdot 1,531 \cdot 8,022}{10^{-5}} = 1,036 \cdot 10^8 \quad (5.18)$$

Otpor se računa prema metodi A.T.T.C., a kao ulazna vrijednost koristi se koeficijent otpora izračunat prema metodi I.T.T.C. iz 1957. g.:

$$Cf_{ITTC} = \frac{0,075}{(\log_{10}(Re) - 2)^2} = \frac{0,075}{(\log_{10}(1,036 \cdot 10^8) - 2)^2} = 0,00207 \quad (5.19)$$

$$Cf_{ATTC} = \left( \frac{0,242}{\log_{10}(Re \cdot Cf)} \right)^2 = \left( \frac{0,242}{\log_{10}(1,036 \cdot 10^8 \cdot 0,00207)} \right)^2 = 0,00206 \quad (5.20)$$

S obzirom na to da je trup izrađen iz staklo plastičnog materijala, uzet je korekcijski faktor  $\Delta Cf = 0,0004$ .

Sila otpora trenja određena je kao

$$Df = \frac{(Cf + \Delta Cf) \frac{\rho}{2} \lambda U^2 B^2}{\cos(\beta)}$$

$$Df = \frac{(0,00206 + 0,0004) \frac{1,94}{2} \cdot 1,531 \cdot 84,390^2 \cdot 8,022^2}{\cos(24,5^\circ)} = 1839,52 \quad (5.21)$$

**Lift of Planing Surfaces**  
Beta = 25° Nonlinear

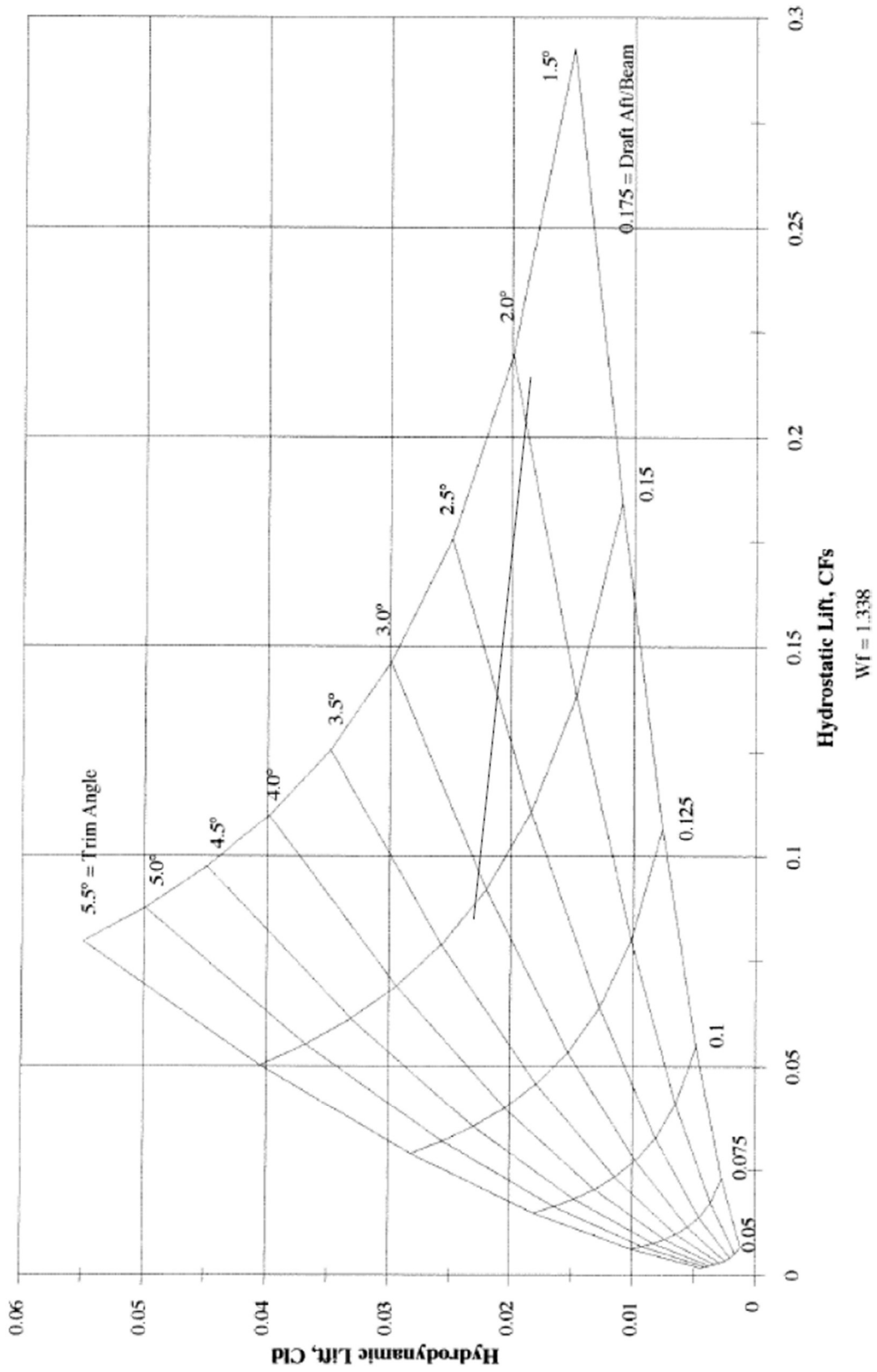

Slika 5.2 Pravec (5.12) ucrtan u dijagram koeficijenata uzgona

### Pitching Moments of Planing Surfaces

Beta = 2.5° Nonlinear

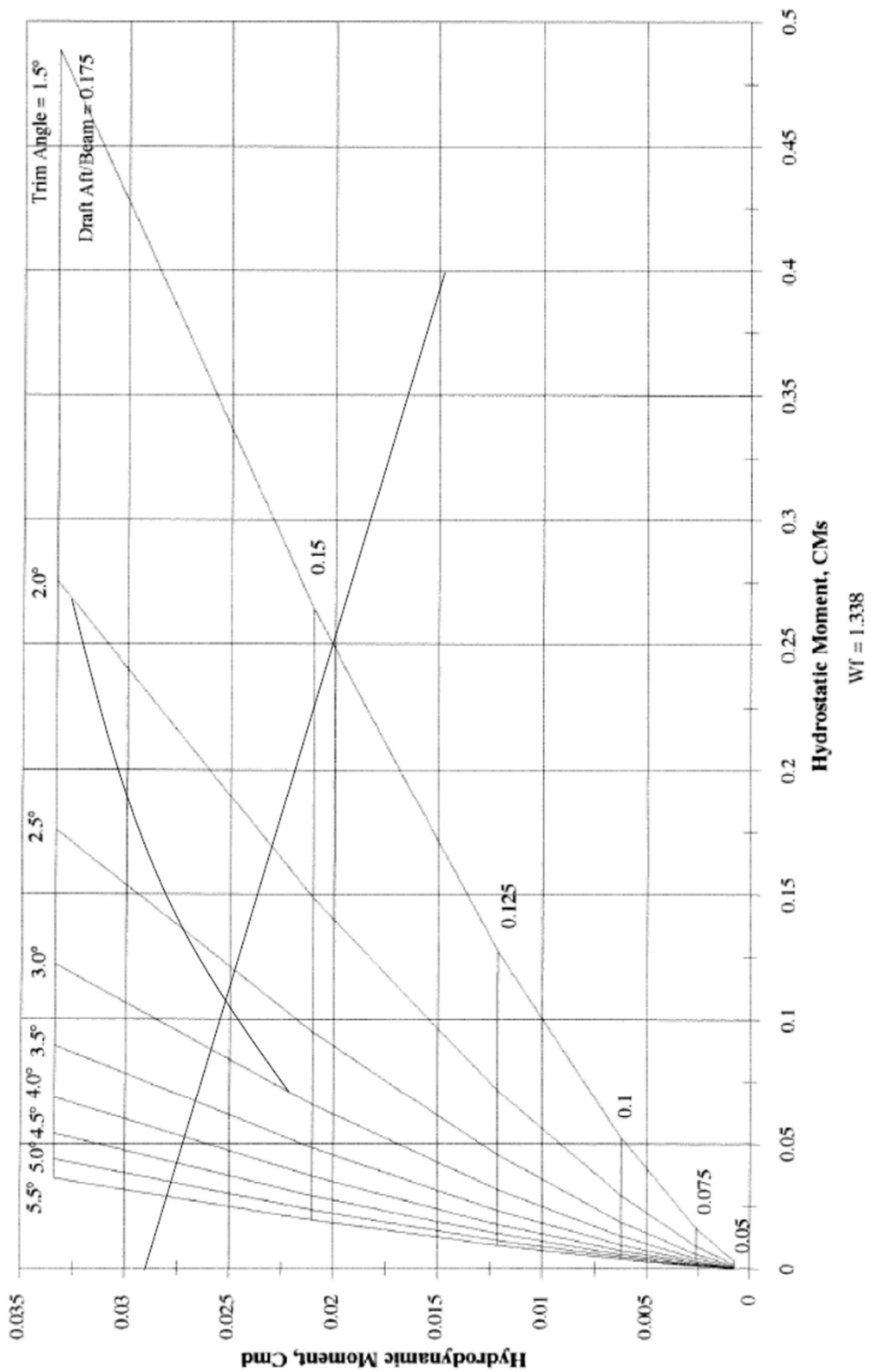

Slika 5.2 Linije (5.12) i (5.14) ucrtane u dijagram koeficijenata momenta posrtanja

Novi koeficijent uzgona računa se na sljedeći način:

$$Cl = \frac{\Delta - (Df + \Delta \sin(\eta)) \frac{\sin(\eta + \varepsilon)}{\cos(\varepsilon)} + Df \cdot \sin(\eta)}{\frac{1}{2} \rho U^2 B^2} = 0,0255 \quad (5.22)$$

Slično kao što je gore navedeno, dobiven je pravac:

$$Cl_d = Cl - \frac{1}{Cv^2} CF_s = 0,0255 - 0,036 \cdot CF_s \quad (5.23)$$

Taj je pravac ucrtan u dijagram koeficijenata uzgona, te su očitana sjecišta s linijama konstantnog trima koje su prikazane u Tablici 5.3. Dijagram je prikazan na Slici 5.3.

Tablica 5.3 Očitavanja iz dijagrama koeficijenata uzgona

$\eta_5, ^\circ$	$T_a$
2,0	0,169
2,5	0,159
3,0	0,151

Novi koeficijent momenta posrtnja izračunat je na sljedeći način:

$$Cm = \frac{(\Delta \cos(\eta_5) L_{CG} - \Delta \sin(\eta_5) V_{CG} - (Df + \Delta \sin(\eta_5))h - Df \frac{B}{4} \tan(\beta)) \cos(\eta_5)}{\frac{1}{2} \rho U^2 B^3}$$

$$Cm = 0,028 \quad (5.24)$$

Novi pravac za unos u dijagram koeficijenata nagibnog momenta dobiven je jednadžbom:

$$Cm_d = Cm - \frac{1}{Cv^2} CM_s = 0,028 - 0,036 \cdot CM_s \quad (5.25)$$

Dijagram je prikazan na Slici 5.4.

Sjecište ovog pravca i pravca definiranog u prethodnom koraku ima koordinate:

$$\eta_5 = 2,688^\circ$$

$$T_a = 0,156$$

Ovime je završen prvi prolaz kroz algoritam.

Ponovljeni su koraci od izračuna (5.15) nadalje s novim ulaznim vrijednostima. Dobiveni rezultati ne razlikuju se od prikazanih u prva tri decimalna mjesta. Na temelju toga zaključeno je da daljnja iteracija nije potrebna i da su dobivene vrijednosti dinamičkog kuta trima i bezdimenzijskog gaza zadovoljavajući.

Sila ukupnog otpora plovila izračunata je sljedećim izrazom:

$$R_T = \Delta \tan(\eta_5) + \frac{Df}{\cos(\eta_5)} = 11446,2 \cdot \tan(2,688) + \frac{1839,52}{\cos(2,688)}$$

$$R_T = 2356,17 \text{ lbs} \quad (5.26)$$

Preračunato u SI sustav jedinica, vrijedi  $R_T = 9,705 \text{ kN}$ .

Snaga otpora računa se kao:

$$P_E = DU = 9,705 \text{ kN} \cdot 25,72 \frac{\text{m}}{\text{s}} = 249,609 \text{ kW} \quad (5.27)$$

Isti proračun proveden je za raspon brzina od 20 do 50 čvorova s inkrementima od 5 čvorova, te su dobivene sljedeće vrijednosti dinamičkih kutova trima, otpora i snage otpora:

*Tablica 4.4 Rezultati proračuna hidrodinamičkih značajki plovila*

$V$ , kn	$\eta_5$ , °	$R_T$ , kN	$P_E$ , kW
20	2,910	5,766	59,325
25	3,425	6,555	84,299
30	3,772	7,198	111,087
35	3,270	7,663	137,974
40	3,125	8,044	165,530
45	2,900	8,843	204,709
50	2,687	9,704	249,609

Rezultati su prikazani grafički na Slikama 5.3, 5.4 i 5.5.

**Lift of Planing Surfaces**  
Beta = 25° Nonlinear

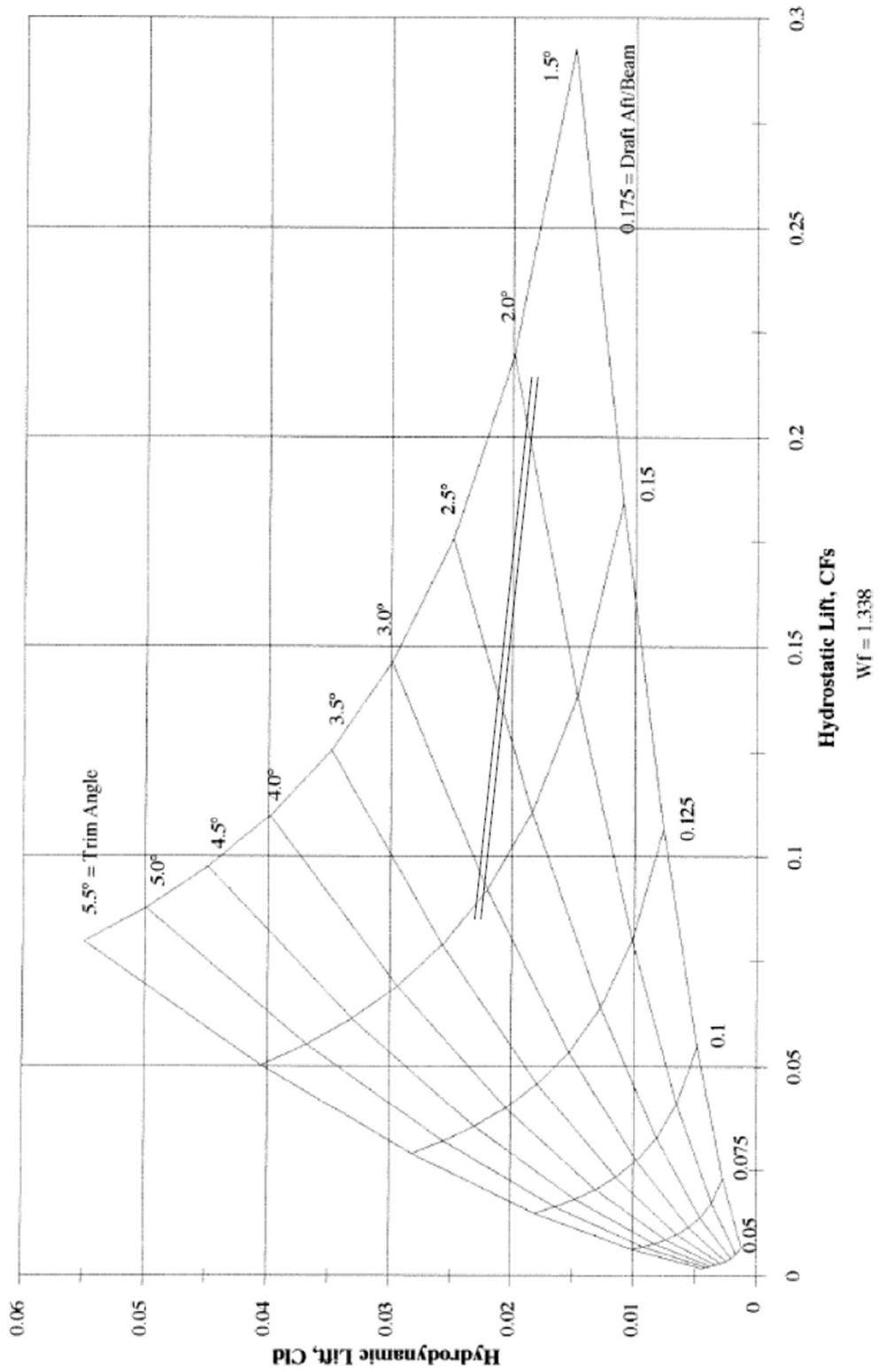

Slika 5.3 Pravci (5.12) i (5.23) ucrtni u dijagram koeficijena uzgona

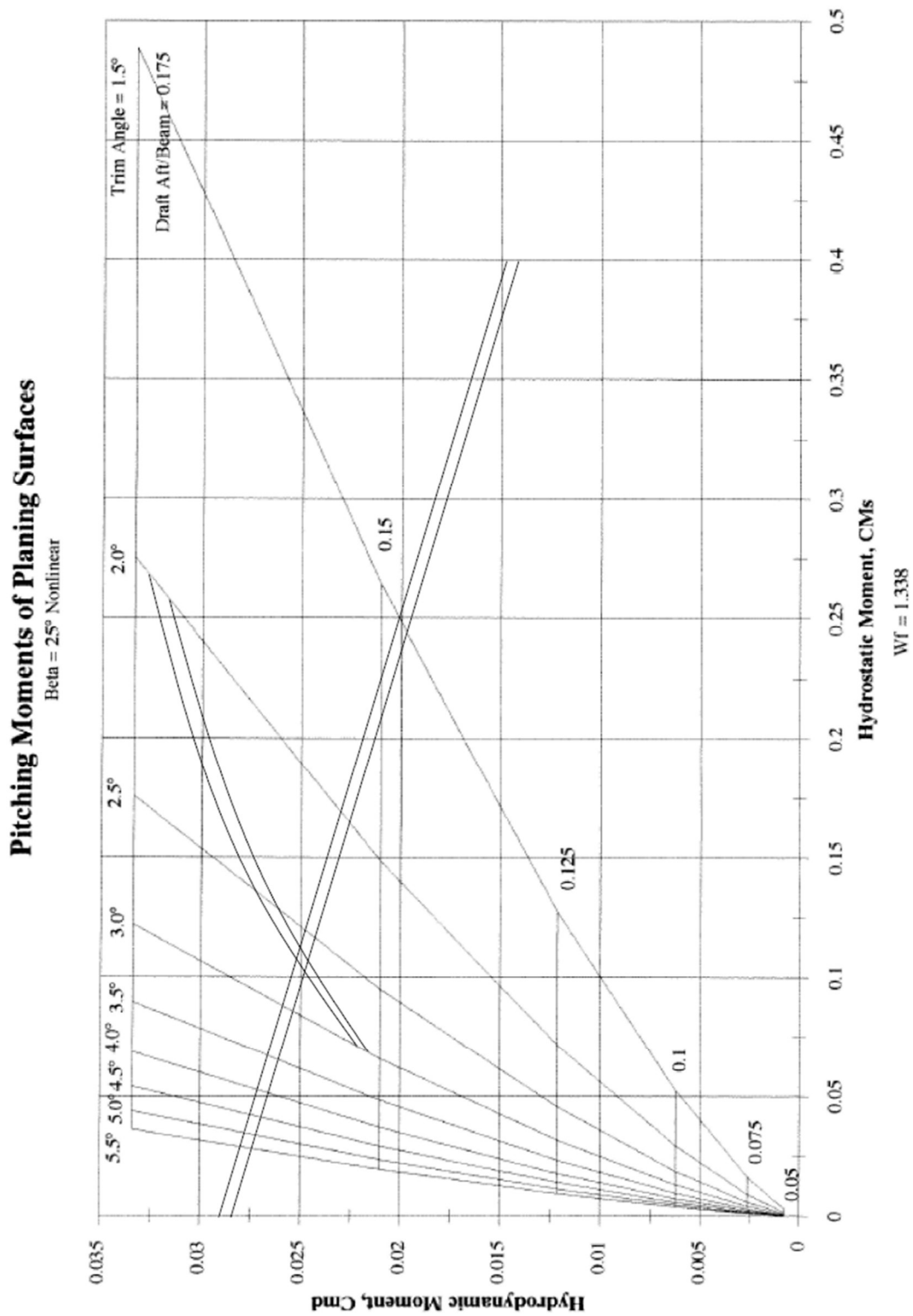

Slika 5.4 Krivulje (5.12), (5.23), (5.14) i (5.25) ucrtane u dijagram koeficijenata momenta



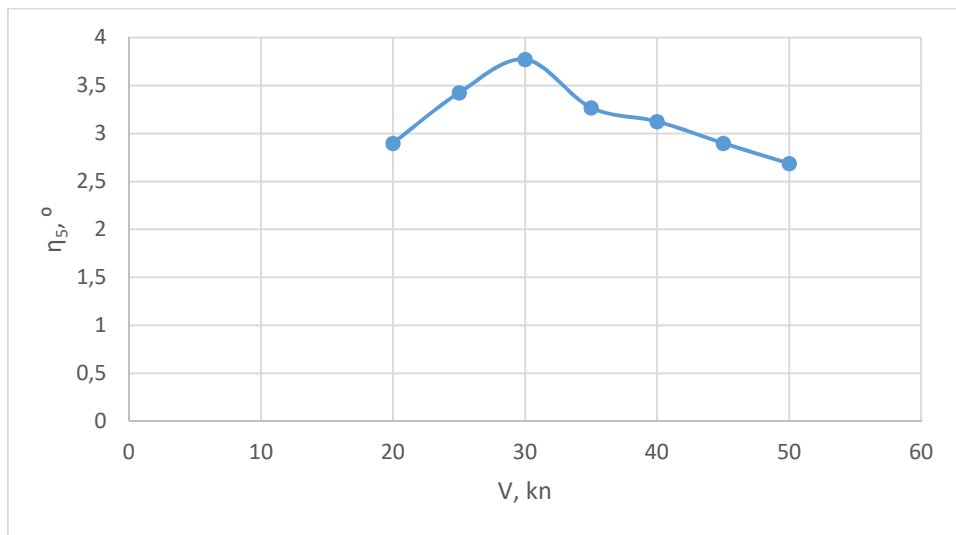

*Slika 5.3 Veličina dinamičkog kuta trima u funkciji brzine*

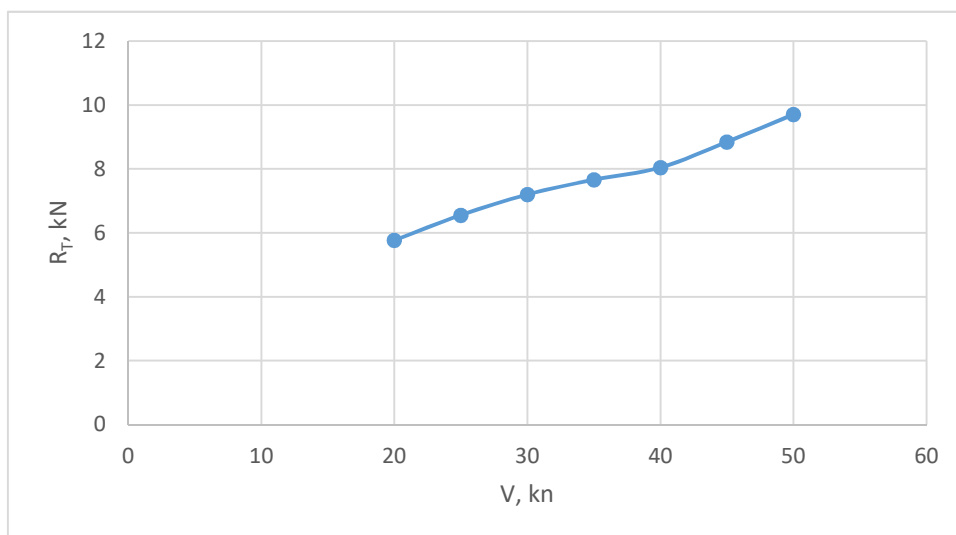

*Slika 5.4 Veličina sile otpora u funkciji brzine*

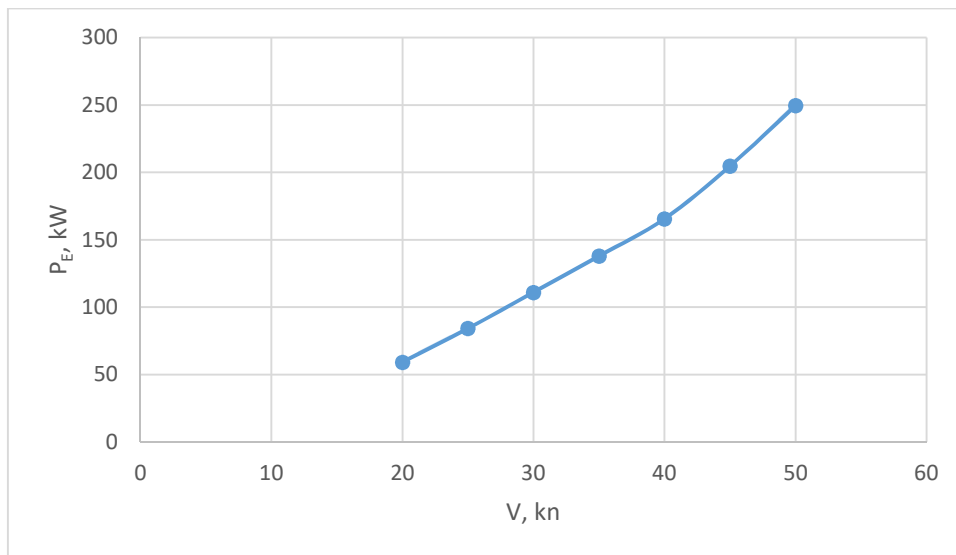

*Slika 5.5 Veličina snage otpora u funkciji brzine*

## 6. Zaključak

U ovom radu obrađeni su hidromehanički aspekti brzog motornog plovila duljine 10,5 m. Odabrana forma trupa modelirana je u programskom paketu *Rhinoceros 7* i određene su hidrostatičke značajke trupa pomoću paketa *Orca 3D*. Izrađen je proračun stabiliteta prema ISO 12217-1:2017, te su određene hidrodinamičke značajke trupa bez privjesaka na mirnoj vodi za jedno odabrano stanje opterećenja.

Modeliranje gliserske forme, iako u načelu jednostavno, zahtijeva određenu vještinu, preciznost i strpljenje. S obzirom na veliki broj ploha koje sačinjavaju formu, posao modeliranja dodatno se komplicira jer svaka od tih ploha zahtijeva zadovoljavanje glatkoće i kontinuiranosti.

Prikazanim postupcima proračuna i procjene utvrđeno je da zadano plovilo zadovoljava uvjete stabiliteta prema normi EN ISO 12217:2017.

Procjenom hidrodinamičkih aspekata forme primjenom Royceove metode određene su važne veličine koje opisuju plovidbu pri glisiranju, i to za raspon brzina od 20 do 50 čvorova kao mjerodavno i reprezentativno područje.

Royceova metoda pokazala se kao relativno jednostavna za korištenje, jer se primjenom tabličnog kalkulatora vrlo brzo dolazi do relevantnih parametara, a korištenje dijagrama brzo je i efikasno. Također, iako je algoritam procjene definiran kako iterativni postupak, za ovaj slučaj pokazalo se da za postizanje zadovoljavajućih rezultata nije potreban velik broj iteracija, jer se konvergencija rezultata redovito postizala već u drugoj iteraciji. Ovo pojednostavljenje dodatno potvrđuje Royceovu metodu kao lako primjenjivu i efikasnu.

## Literatura

- [1] International Marine Certification Institute, »CALCULATION TOOLS & CHECKLISTS,« [Mrežno]. Available: <https://www.imci.org/52>. [Pokušaj pristupa 15 07 2023].
- [2] Royce, R.A., A Rational Prismatic Hull Approach For Planing Hull Analysis, Presented at the SNAME, GREAT LAKES AND GREA RIVERS SECTION MEETING, CLEVELAND, OHIO, 1994..

## Popis oznaka i kratica

$A_{WL}$	površina vodne linije, $m^2$
$B$	širina na zgibu, m
$BM_L$	uzdužni metacentarski radijus, m
$BM_T$	poprečni metacentarski radijus, m
$B_{OA}$	širina preko svega, m
$C_B$	koeficijent punoće istisnine
$CF_d$	bezdimenzijski koeficijent dinamičke sile
$CF_s$	bezdimenzijski koeficijent statičke sile
$Cl$	bezdimenzijski koeficijent uzgona
$Cl_d$	bezdimenzijski koeficijent hidrodinamičkog uzgona
$Cl_s$	bezdimenzijski koeficijent hidrostatskog uzgona
$C_M$	koeficijent punoće glavnog rebra
$C_m$	bezdimenzijski koeficijent momenta posrtanja
$C_{m_d}$	bezdimenzijski koeficijent nagibnog momenta
$C_P$	prizmatički koeficijent
$C_V$	Froudeov broj širine
$C_{WP}$	koeficijent punoće površine vodne linije
$D$	visina plovila, m
$D_f$	sila otpora trenja, N
$f_s$	jedinični hidrostatski uzgon
$F_s$	statička sila
$h$	visina osovine broskog vijka od osnovice, m
$KB$	visina težišta istisnine, m
$LCB$	uzdužni položaj težišta istisnine, m
$LCF$	uzdužni položaj težišta površine vodne linije, m
$LCG$	uzdužni položaj težišta sustava, m
$LOA$	duljina preko svega, m
$L_{WL}$	duljina vodne linije, m
$P_E$	snaga ukupnog otpora, kW
$Re$	Reynoldsov broj

$R_T$	sila ukupnog otpora, N
$T$	gaz, m
$T_a$	bezdimenzijski gaz
$TCG$	poprečni položaj težišta sustava, m
$U$	brzina, m/s
$V$	volumen istisnine, m <sup>3</sup>
$VCG$	vertikalni položaj težišta sustava, m
$Wf$	faktor oplakivanja
$\beta$	nagib dna, °
$\Delta$	deplasman, kg
$\Delta C_f$	korekcijski faktor
$\varepsilon$	nagib osovine, °
$\eta_5$	trim, °
$\lambda$	srednji omjer oplakivanje duljine i širine
$\rho$	gustoća morske vode, kg/m <sup>3</sup>
$\tau_c$	bezdimenzionalno vrijeme, trenutak uranjanja zgiba

## Popis slika i tablica

### POPIS SLIKA

Slika 2.2 Nacrt linija plovila .....	3
Slika 2.3 Mreža s linijama rebara na odgovarajućim pozicijama .....	4
Slika 2.4 Linije zgibova, kobilice i razme (plavo) .....	4
Slika 2.5 Forma plovila .....	5
Slika 2.6 Prikaz forme i krmenog zrcala .....	5
Slika 2.7 Prikaz palube.....	6
Slika 2.8 Prikaz palube.....	6
Slika 3.1 Dijagramski list .....	7
Slika 3.2 Dijagram ovisnosti koeficijenata forme o gazu .....	8
Slika 4.1 Poluga stabiliteta za stanje punog opterećenja (engl. Loaded Displacement Condition)	
Slika 4.2 Poluga stabiliteta za minimalno radno stanje (engl. Minimum Operating Condition) ..	12
Slika 5.2 Pravac (5.12) ucrtan u dijagram koeficijenata uzgona.....	20
Slika 5.2 Linije (5.12) i (5.14) ucrtane u dijagram koeficijenata momenta posrtanja .....	21
Slika 5.3 Pravci (5.12) i (5.23) ucrtani u dijagram koeficijenata uzgona .....	24
Slika 5.4 Krivulje (5.12), (5.23), (5.14) i (5.25) ucrtane u dijagram koeficijenata momenta .....	25
Slika 5.3 Veličina dinamičkog kuta trima u funkciji brzine .....	26
Slika 5.4 Veličina sile otpora u funkciji brzine.....	26
Slika 5.5 Veličina snage otpora u funkciji brzine .....	27

## POPIS TABLICA

Tablica 4.1 Raspodjela masa za stanje punog opterećenja (engl. Loaded Displacement Condition)	9
Tablica 4.2 Koordinate težišta za stanje punog opterećenja (engl. Loaded Displacement Condition).....	10
Tablica 4.3 Raspodjela masa za minimalno radno stanje (engl. Minimum Operating Condition)	10
Tablica 4.4 Koordinate težišta za minimalno radno stanje (engl. Minimum Operating Condition)	10
Tablica 4.5 Raspodjela masa za stanje opterećenja plovila u dolasku (engl. Loaded Arrival Condition).....	11
Tablica 4.6 Koordinate težišta za stanje opterećenja plovila u dolasku (engl. Loaded Arrival Condition).....	11
Tablica 5.1 Ulazni podatci za proračun.....	17
Tablica 5.2 Očitavanja s dijagrama koeficijenata uzgona.....	18
Tablica 5.3 Očitavanja iz dijagrama koeficijenata uzgona .....	22
Tablica 4.4 Rezultati proračuna hidrodinamičkih značajki plovila.....	<b>Pogreška! Knjižna oznaka nije definirana.</b>



## Sažetak

U ovom radu obrađene su hidromehaničke osobine brzog plovila na mehanički pogon duljine 10.5 m. Rad se bavi modeliranjem forme trupa u programskom paketu *Rhinoceros 7*, analizom stabiliteta i analizom hidrodinamičkih aspekata pri gliserskom režimu plovidbe. Stabilitet plovila procijenjen je prema normi ISO 12217-1:2017 koristeći javno dostupan tablični kalkulator. Hidrodinamički aspekti analizirani su metodom „*A Rational Prismatic Hull Approach For Planing Hull Analysis*“ autora Richarda A. Roycea. Pritom su određene hidrodinamičke karakteristike za niz reprezentativnih brzina. Rezultati su prikazani tablično i grafički.

Ključne riječi: brzo motorno plovilo, gliserska forma, hidromehaničke značajke, 3D model, stabilitet, ukupni otpor, dinamički trim

## Summary

This paper deals with the hydromechanical properties of a fast mechanically powered vessel with a length of 10.5 m. The paper deals with the modeling of the hull form in the *Rhinoceros 7* software package, the analysis of stability and the analysis of hydrodynamic aspects in the speedboat mode of navigation. Vessel stability was assessed according to the ISO 12217-1:2017 standard using a publicly available spreadsheet calculator. Hydrodynamic aspects were analyzed using the method "A Rational Prismatic Hull Approach For Planing Hull Analysis" by Richard A. Royce. In doing so, hydrodynamic characteristics were determined for a number of representative speeds. The results are presented tabularly and graphically.

Key words: fast motor vessel, planing hull, hydromechanical aspects, 3D model, stability, total resistance, dynamic trim

## **Prilozi**

PRILOG 1 Nacrt forme

PRILOG 2 Tablični kalkulator za proračun stabiliteta prema EN ISO 12217:2017

**ISO 12217-1:2017 NON-SAILING BOATS OF LENGTH GREATER THAN OR EQUAL TO 6m**

Manufacturer:	ZAVRŠNI RAD
Signatory, Name:	PETRA LUKAČIĆ
Signatory, Title:	
Phone:	
Email:	
WWW:	
CIN Model Year:	
Model Name:	CONTENDER 34

*This calculation sheet is provided by IMCI "as is" and any express or implied warranties, including, but not limited to, the implied warranties of fitness for a particular purpose are disclaimed.*

blue cells are derived values

yellow cells require data input

Please make sure to set your signature on the summary! (worksheet 12)  
either digitally or print summary, sign and attach scan

- most worksheets have additional comments / remarks / other calculations beside the printout area; please take into account.
- For boats in category A and B either fill in worksheet 6c and 6d or attach curve of righting moments for both loading conditions to the documentation.
- For boats with quick-draining cockpit the cockpit calculation according to ISO 11812 shall be enclosed to the documentation.
- Please attach other detailed information as appropriate, e.g. photos, sketches etc. for sill height, openings, companion way doors, location of flooding points, practical tests etc.
- When entering data, please use the correct separator for your Excel version, many application problems are the result of incorrect separators ( , or . )
- Please send questions, found errors, typos, mistakes, ect. directly to ralf.dewender@imci.org or to the headoffice with info@imci.org; every comment helps us to provides you with a better version
- Please be aware that there is NO technical difference between the requirements of ISO 12217-1:2015 and EN ISO 12217-1:2017; change of the name is just because of the harmonisation process; for ISO 12217-1:2020 the main change is the exclusion of optional equipment and margin for future additions from the maximum load and the result of the "maximum recommended load for builder's plate" (with ISO 14945:2021 and ISO 14946:2021 renamed to "maximum load for the builder's plate,  $m_{MBP}$ ") which exludes OB engine weights and the optional equipment.

**ISO 12217-1:2017 NON-SAILING BOATS OF LENGTH GREATER THAN OR EQUAL TO 6m  
CALCULATION WORKSHEET No. 1**

ISO 12217-1:2017 en220801

ZAVRŠNI RAD CONTENDER 34

Design Category intended:	B	Monohull / Multihull:	Monohull	Propul.Type:	OB
Item	Symbol	Unit	Value	Ref.	
Length of hull as in ISO 8666	$L_H$	m	10,40		3.3.1
Length of waterline in loaded arrival condition	$L_{WL}$	m	8,70		3.3.2
<b>Empty Craft condition mass</b>	$m_{EC}$	kg	2705,0		3.4.1
standard equipment (incl. OB engine(s) and ess. safety equipment)		kg	1560,0		3.5.12
water ballast in tanks which are notified in the owner's manual to be filled when the boat is afloat		kg	0,0		3.4.2
<b>Light craft condition mass</b>	$m_{LC}$	kg	4265,0		3.4.2
<b>Mass of:</b>					
Desired crew limit	CL	----	6		3.5.3
Mass of:					
desired crew limit at 75 kg each		kg	450,0		
provisions + personal effects		kg	150,0		3.4.4
drinking water		kg	80,8		3.4.4
fuel		kg	1117,8		3.4.4
lubricating and hydraulic oils		kg	0,0		3.4.4
black water		kg	0,0		3.4.4
grey water		kg	0,0		3.4.4
water ballast		kg	85,3		3.4.4
other fluids carried aboard		kg	0,0		3.4.4
stores, spare gear and cargo (if any)		kg	68,0		3.4.4
inflatable life raft(s) in excess of essential safety equipment		kg	40,0		3.4.4
other small boats carried aboard		kg	0,0		3.4.4
<b>Maximum load = sum of above masses using ISO ISO 12217-1:2020</b>	$m_L$	kg	1991,9		3.4.4
optional equipment and fittings not included in basic outfit		kg	35,0		3.4.4 / 3.4.5
<b>Maximum load = sum of above masses using ISO 12217-1:2017</b>	$m_L$	kg	2026,9		3.4.4
<b>Maximum Load condition mass</b>	$m_{LDC}$	kg	6291,9		3.4.5
Mass to be removed for loaded arrival condition		kg	1100,0		3.4.6
<b>Loaded Arrival condition mass</b>	$m_{LA}$	kg	5191,9		3.4.6
Mass of:					
minimum number of crew weight according to 3.4.3		kg	150,0		3.4.3a)
non-consumable stores and equipment normally aboard		kg	40,0		3.4.3b)
inflatable life raft		kg	40,0		3.4.3
<b>Load to be included in Minimum Operating Condition</b>	$m'_L$	kg	230,0		3.4.3
<b>Light craft condition mass</b>	$m_{LC}$	kg	4265,0		3.4.2
<b>Mass in the Minimum Operating Condition</b>	$m_{MO}$	kg	4495,0		3.4.3
<b>Maximum load for the builder's plate using EN ISO 14946:2021 and EN ISO 14945:2021 (if manually reduced on Worksheet 1b the reduced value is shown)</b>	$m_{MBP}$	kg	708,0		
<b>Is boat sail or non-sail?</b> Nominal sail area	$A_S^*$	m <sup>2</sup>	0,0		3.3.8
Sail area / displacement ratio = $A_S / (m_{LDC})^{2/3}$		----	0,0000		3.1.2
CLASSIFIED AS [non-sail if $A_S / (m_{LDC})^{2/3} < 0.07$ ]		SAIL/NON-SAIL ?	<b>NON-SAIL</b>		3.1.2

NB If NON\_SAIL, continue using these worksheets, if SAIL, use ISO 12217-2

## ISO 12217-1:2017 / ISO 14945:2021 CALCULATION WORKSHEET No.1b Builder's plate

ZAVRŠNI RAD CONTENDER 34

Since 2021-12-09 EN ISO 14945:2021 and EN ISO 14946:2021 are harmonised!

The formerly 'Maximum recommended load for builder's plate' became '**Maximum load for the builder's plate**',  $m_{MBP}$ .

$m_{MBP}$  does not include the optional equipment anymore; also the weight of outboard engines is excluded from  $m_{MBP}$  and can be shown in a separated line on the plate.

Below you find two examples for the builder's plates with the maximum value for  $m_{MBP}$  calculated from the stability calculation on worksheet 1; one for craft powered by outboard engines, one for craft powered by inboard or sterndrive engines.

For portable tanks, please change the default 'yes' on the right side in 'no, portable tank'; the weight of the tank will be included in  $m_{MBP}$ .

Please be aware that ISO 14946:2021 allows in clause 6 that the maximum recommended load can be downrated or limited by the manufacturer at any time. Therefore you find an extra cell to enter a manual reduced value for the maximum load for the builder's plate.

Default outboard engine mass is calculated with the help of table F.1 from EN ISO 12217-1:2017; nevertheless the manufacturer can insert the actual engine mass the boat model is calculated with.

This is strongly recommended for engines with more than 164,2 kW which are outside the table range (means all 300, 350, 400, 450 and more HP outboard engines) !

Please be also aware that the design of these plates is just a proposal from EN ISO 14945, the manufacturer is free to change the design as long all requirements of the standard are fulfilled.

Item	Value	Unit	Ref.
Manually reduced value for the 'Maximum load for the builder's plate' $m_{MBP}$	708	kg	EN ISO 14945, cl. 6, note 2
Maximum engine power of a single engine	300	kW	
Maximum number of engines	2		
Actual value of the max. outboard engine mass, (sum of all engines) as defined by the manufacturer and used for stability calculation (default value is table F.1 from ISO 12217-1:2017 value)	625	kg	EN ISO 12217-1:2017 table F.1

Please see builder's plate example with values calculated from worksheet 1 entries on next page:

Builder's plate information for craft powered by outboard engines -- Example

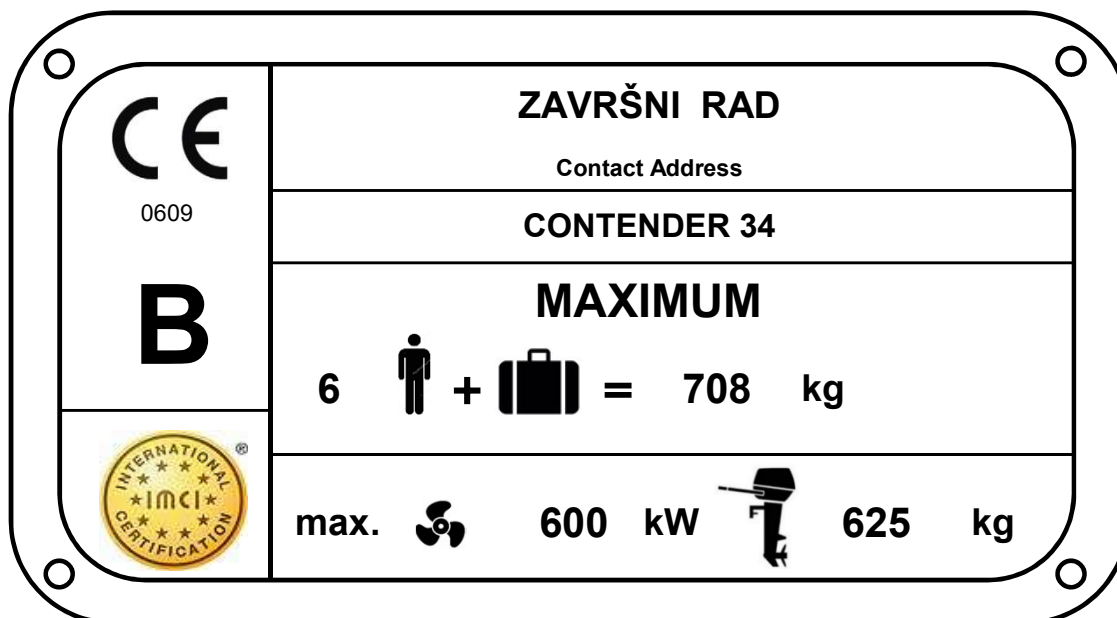

Builder's plate information for craft powered by inboard or sterndrive engines

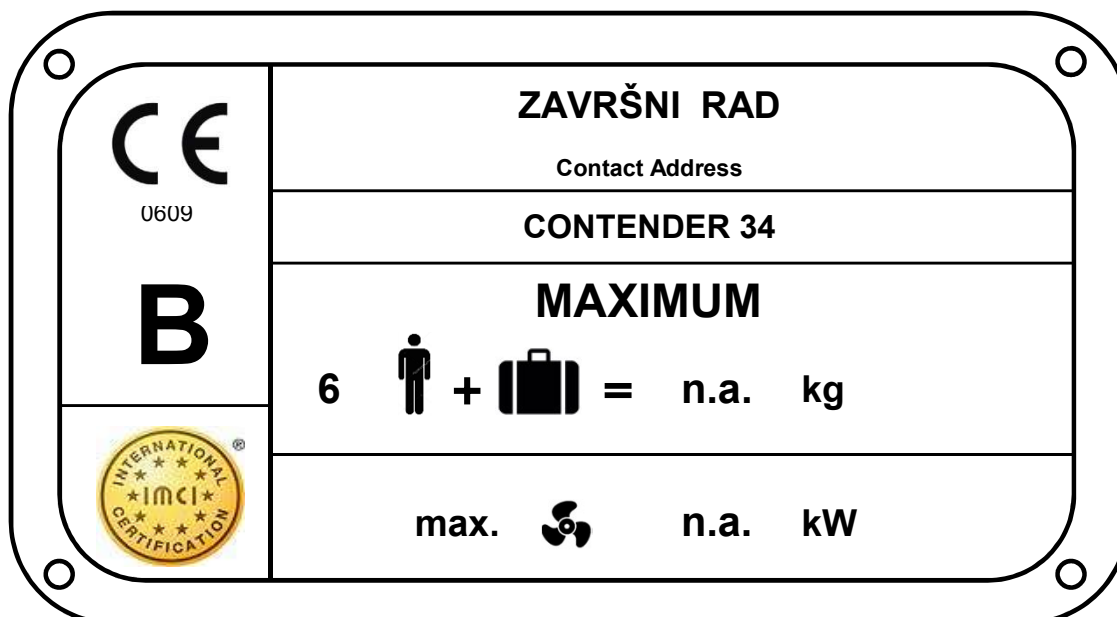

## ISO 12217-1:2017 CALCULATION WORKSHEET No.2 TESTS TO BE APPLIED

ZAVRŠNI RAD CONTENDER 34

Question	Answer	Ref.
Is boat fully enclosed? (see definition in ref.) YES/NO?	Yes	3.1.6
Is boat partially protected? (see definition in ref.) YES/NO?	No	3.1.7

Item	Symbol	Unit	Value	Ref.
Windage area in minimum operating condition	$A_{LV}$	$m^2$	9,18	3.3.7
Length of Hull	$L_H$	m	10,40	3.3.2
Beam of hull	$B_H$	m	2,91	3.3.3
Freeboard ad midships	$F_M$	m	0,98	3.3.5
Ratio $A_{LV}/(L_H B_H)$		----	0,30	

Choose any ONE of the following options and use all the worksheets indicated for that option.

Option	1	2	3	4	5	6
Categories possible	A and B	C and D	B	C and D	C and D	C and D
Decking or covering	fully enclosed	fully enclosed	any amount	any amount	partially protected	any amount
Downflooding openings	3	3	3	3	3	3
downflooding angle	3		3			
Downflooding height test	All boats	3	3	$3^a$	3	3
	Annex A method	4	4	$4^a$	4	4
Offset load test	5	5	5	5	5	5
Resistance to waves + wind	6		6			
Heel due to wind action		$7^b$		$7^b$	$7^b$	$7^b$
Recess size	8	$8^c$				$8^c$
Habitable multihulls	9	9	9	9	9	9
Motor sailers	9	9	9	9	9	9
Flotation test			10	10		
Flotation material			10	10		
Detection and removal of water	11	11	11	11	11	11
SUMMARY	12	12	12	12	12	12

a. The downflooding height test is not required to be conducted on the following Category C and D boats:

I. those which, when tested in accordance with normative annex F.4, have been shown to support, in addition to the mass required by F.2 and Table F.5, an additional equivalent dry mass (kg) of (75-CL + 10% of dry weight of stores and equipment included in the maximum total load), or  
 II. those boats that do not take on water when heeled to 90° from the upright in the light craft condition.

b. The application of Worksheet 7 is only required for boats where  $A_{LV}/(L_H B_H) > 0,5$ .

c. Only required for boats of design category C; for option 6 clause 6.5.4 only

Option selected	1
-----------------	---

## ISO 12217-1:2017 CALCULATION WORKSHEET No. 3 DOWNFLOODING

ZAVRŠNI RAD CONTENDER 34

### Downflooding Openings:

Question	Answer	Ref.
Have all appropriate downflooding openings been identified?	Yes	3.2.1
Have potential downflooding openings within the boat been identified?	Yes	6.1.1.4
Do all closing appliances satisfy ISO 12216?	Yes	6.1.1.1
Hatches or opening type appliances are not fitted below minimum height above waterline? *	Yes	6.1.1.2
Seacocks comply with requirements?	Yes	6.1.1.3
Are all openings on design category A or B boats fitted with closing appliances? **	Yes	6.1.1.5
<b>Categories possible:</b> A or B if all are YES, C or D if first five are YES	<b>A</b>	6.1.1

\* Except for emergency escape hatches on design category C boats, where 0,1 m is allowable \*\* Except openings for ventilation and engine combustion

### Exemptions Downflooding Openings:

Question	Answer	Ref.
Drains from quick-draining recesses or watertight recesses acc. to cl. 6.1.1.6 b) are either:		
1) freeing ports with non-return flaps which are watertight from the exterior (degree 3) or		6.1.1.6 b)
2) have a drainage area smaller than three times the minimum area required of ISO 11812		6.1.1.6 b)
		6.1.1.6 b)
Opening appliances (e.g. side doors) in the topsides which comply with ISO 12216 are		
1) referenced in the owner's manual as watertight closure to be kept shut when under way, and		6.1.1.6 d)
2) marked inboard with "KEEP SHUT WHEN ..." in upper case letters not less than 4,8 mm high, and		6.1.1.6 d)
3) the height above waterline of the lowest part is > 50% of required downflooding height		6.1.1.6 d)
		6.1.1.6 d)
All other exemptions of cl. 6.1.1.6 checked and requirements fulfilled?		6.1.1.6
		6.1.1.6

### Downflooding angle (required for cat A & B only\*):

Item	Symbol	Unit	Value	Ref.
required Category A = larger of $(\phi_O + 25)^\circ$ or $30^\circ$	$\phi_{D(R)}$	degrees	n.a.	6.1.3; Table 3
required Category B = larger of $(\phi_O + 15)^\circ$ or $25^\circ$	$\phi_{D(R)}$	degrees	<b>29,00</b>	6.1.3; Table 3
Area of openings permitted to be submerged = $1.2 L_H B_H F_M$		cm <sup>2</sup>	<b>35,41</b>	6.1.3
Actual downflooding angle: at mass = $m_{MO}$	$\phi_{DA}$	degrees	<b>35,97</b>	6.1.3
at mass = $m_{LA}$	$\phi_{DA}$	degrees	<b>34,89</b>	6.1.3
Method used to determine $\phi_D$ .				Annex C
Design category possible on Downflooding Angle:			<b>B</b>	6.1.3

### Downflooding Height: (all except exempt boats)

Is boat exempted from downflooding height requirements according to 6.1.2.1?					Yes / No	No
Requirement	Basic requirement	Reduced value for small openings	Reduced value at outboard	Increased value at bow		
Applicable to	all options	all options (using figures)	options 3, 4 or 6	options 3, 4, 6		
ref.	6.1.2.2 a)	6.1.2.2 d)	6.1.2.2 c)	6.1.2.2 b)		
obtained from Figs. 3 + 4 or annex A?	<b>fig 3 &amp; 4</b>	= basic x 0.75	= basic x 0.80	= basic x 1.15		
Maximum area of small openings ( $50L_H^2$ ) (mm <sup>2</sup> ) =		5408	////////	////////		
Required downflooding height $h_{D(R)}$	Fig. 3/ann. A	Category A	<b>0,61</b>	<b>0,46</b>	<b>0,49</b>	<b>0,70</b>
	Fig. 3/ann. A	Category B	<b>0,61</b>	<b>0,46</b>	<b>0,49</b>	<b>0,70</b>
	Fig. 3/ann. A	Category C				
	Fig. 4/ann. A	Category D				
Actual Downflooding Height $h_D$		<b>0,844</b>	<b>0,844</b>			
Design Category possible	<b>B</b>	<b>B</b>				
<b>Design Category possible on Downflooding Height = lowest of above</b>						<b>B</b>



## ISO 12217-1:2017 CALCULATION WORKSHEET No.3a DOWNFLOODING OPENINGS / CLOSING APPLIANCES

ZAVRŠNI RAD CONTENDER 34

### General overview downflooding openings and closing appliances

**NOTE:** All drawings are not blocked by a password, so please replace with own drawings if at hand.

**NOTE:** See X,Y, Z coordinates for worksheet 3b as illustrated below

Top View

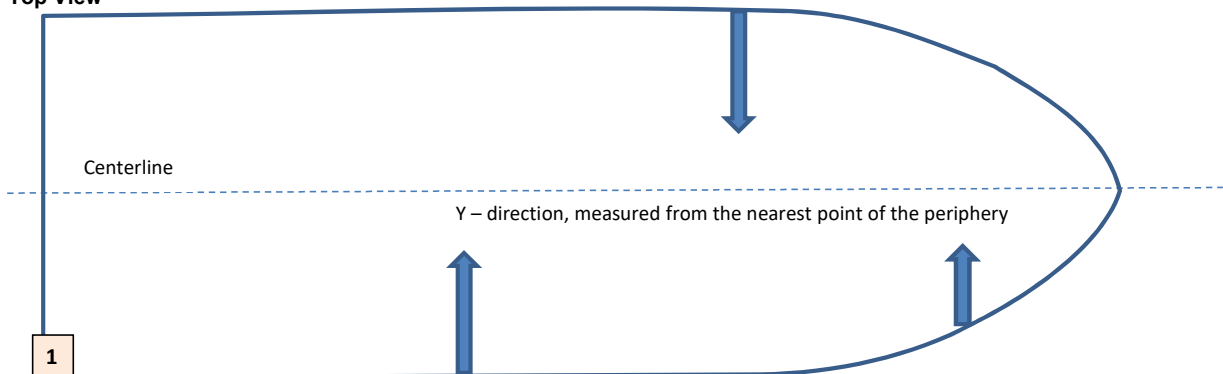

Side View Starboard

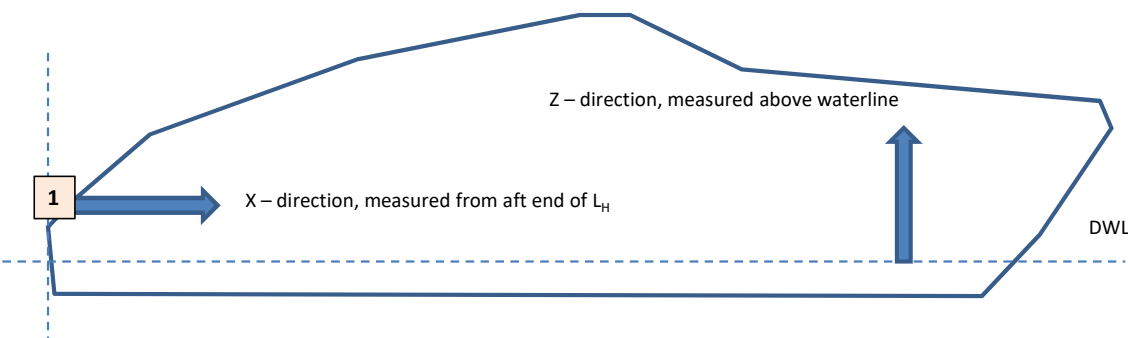

Side View Port

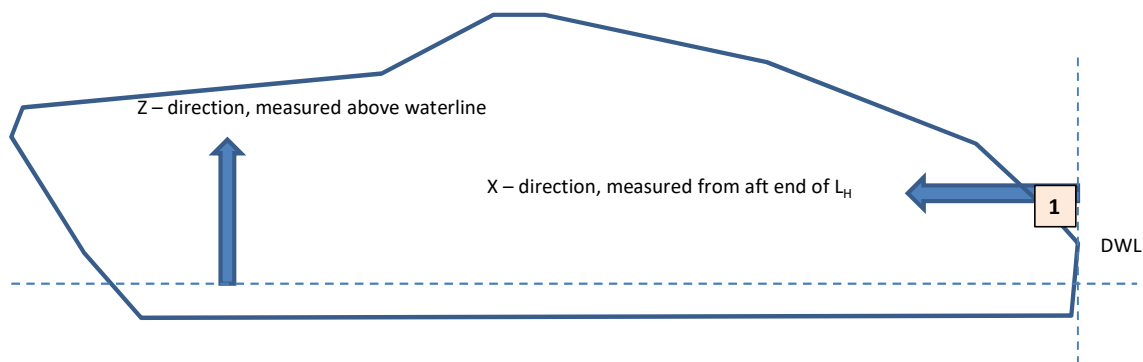

Please insert a short description and measurements of downflooding openings and closing appliances under the corresponding number on worksheet 3b

## ISO 12217-1:2017 CALCULATION WORKSHEET No.3b DOWNFLOODING OPENINGS

ZAVRŠNI RAD CONTENDER 34

### General overview downflooding openings and closing appliances

**NOTE:** Please submit for every pre-fabricated closing appliance a declaration of conformity (DoC) of the product.  
Please submit for every non pre-fabricated closing appliance a calculation acc. to ISO 12216 (see IMCI template).  
For both a watertightness test must be done!

Description of the downflooding opening / closing appliance	Nr.	X <sup>(a)</sup> [m]	Y [m]	Z (=h <sub>D</sub> ) [m]	watertightness test done	opening type <sup>(b)</sup>
Recess	1	0,00	0,08	0,84	n.a.	downflooding opening
	2					
	3					
	4					
	5					
	6					
	7					
	8					
	9					
	10					
	11					
	12					
	13					
	14					
	15					
	16					
	17					
	18					
	19					
	20					
	21					
	22					

**(a)** Please be aware that X is measured from the aft end of L<sub>H</sub>.

In Annex A calculations x<sub>D</sub> is measured from the bow or stern, whichever is nearest

**(b)** opening types are: normal downflooding openings without any opening appliances; pre-fabricated opening appliances; non-pre-fabricated opening appliances and other devices

## ISO 12217-1:2017 CALCULATION WORKSHEET No.4 DOWNFLOODING HEIGHT

ZAVRŠNI RAD CONTENDER 34

### Calculation using annex A

Item	Symbol	Unit	Opening 1	Opening 2	Opening 3	Opening 4
<b>Position of openings</b>						
Least longitudinal distance from bow/stern	$x_D$	m				
Least transverse distance from gunwale	$y_D$	m				
$F_1 = \text{greater of } (1 - x_D/L_H) \text{ or } (1 - y_D/B_H)$	$F_1$	----	1,00	1,00	1,00	1,00
<b>Size of openings:</b>						
Combined area of openings to top of any down-flooding opening	$a$	mm <sup>2</sup>				
Longitudinal distance of opening from tip of bow	$x'_D$	m				
Limiting value of $a = (30L_H)^2$		mm <sup>2</sup>	97344	97344	97344	97344
If $a \geq (30L_H)^2, F_2 = 1,0$						
If $a < (30L_H)^2, F_2 = 1 + \frac{x'_D}{L_H} \left( \frac{\sqrt{a}}{75 L_H} - 0,4 \right)$	$F_2$	----	1,00	1,00	1,00	1,00
<b>Size of recesses:</b>						
Volume of recesses which are not self-draining in accordance with ISO 11812	$V_R$	m <sup>3</sup>				
Is opening not a recess? Is recess quickdraining? Is recess not quickdraining?						
$k = V_R / (L_H B_H F_M)$	$k$	----	0	0	0	0
If opening is not a recess, $F_3 = 1$						
If recess is quickdraining, $F_3 = 0.7$						
If recess is not quick draining, $F_3 = (0.7 + k^{0.5})$	$F_3$	----	1,20	1,20	1,20	1,20
<b>Displacement:</b>						
Loaded displacement volume (see 3.4.5)	$V_D$	m <sup>3</sup>	6,14			
$B = B_H$ for monohulls, $B_{WL}$ for multihulls	$B$	m	2,91			
$F_4 = [(10 V_D) / (L_H B^2)]^{1/3}$	$F_4$	----	0,89			
<b>Flotation:</b>						
For boats using option 3 or 4, $F_5 = 0.8$						
For all other boats, $F_5 = 1.0$	$F_5$	----	1			
<b>Required calculation height:</b> $= F_1 F_2 F_3 F_4 F_5 L_H / 15$	$h_{D(R)}$	m	0,74	0,74	0,74	0,74
Required downflooding height with limits applied (see annex A, Table A.1)	Category A	$h_{D(R)}$				
	Category B	$h_{D(R)}$	0,4	0,4	0,4	0,4
	Category C	$h_{D(R)}$				
	Category D	$h_{D(R)}$				
<b>Measured Downflooding Height:</b>	$h_D$	m				
<b>Design Category possible:</b>						
<b>Lowest of above =</b>						<b>Fail</b>

ISO 12217-1:2017 CALCULATION WORKSHEET - No. 5a

OFFSET LOAD TEST

ZAVRŠNI RAD CONTENDER 34

Mass of people used for test

Name	Ident.	Mass (kg)
Person 1	A	85
Person 2	B	85
Person 3	C	85
Person 4	D	85
Person 5	E	85
Person 6	F	85
Person 7	G	85
Person 8	H	85
Person 9	I	85
Person 10	J	85

downflooding opening obvious to the crew?  Yes

Crew Area

Areas included and access limitations (if any):

Area	P/S	Incl?	Persons limit
Main Cockpit			
Aft Cockpit			
Fwd Cockpit			
Salon			
Cabins			
Side Decks			
Fore Deck			

Offset Load Test

Name	Ident.	Mass (kg)
Person 11	K	85
Person 12	L	85
Person 13	N	
Person 14	M	
Person 15	O	
Person 16	P	
Person 17	Q	
Person 18	R	
Person 19	S	
Person 20	T	

average mass per person:   
 number of persons permitted (through offset load test)

Area	P/S	Incl?	Persons limit
Cuddy Top			
Coachroof Top			
Wheelhouse Top			
Fly Bridge			
Swim Platform			

**Sketch:** Indicate possible seating locations along the length of the side to be tested using numbers, so that these may later be used to record the positions that people actually occupy. Locations should not be closer than 0.5 m between centers, and not less than 0.2 m from outboard edge unless on sidedecks less than 0.4 m wide.

1) Note whether it is asymmetric by adding P (port) or S (starboard) to denote the larger side.

**ISO 12217-1:2017 CALCULATION WORKSHEET - No. 5b**
**OFFSET-LOAD TEST**

ZAVRŠNI RAD CONTENDER 34

**Stability Test - Full Procedure**

Boat being tested for:		X	stability	X	downflooding			please mark	
$L_H$ (m)	Min. permitted freeboard margin (m) (see Table 5)		Max. permitted heel angle (°) $= 11,5 + \frac{(24 - LH)^3}{520}$		Intended crew limit (CL)	Intended design category	Mass Test weights per person (kg) (Cat D only)	Max. Mass of test weights (kg) (= 98 x CL)	
10,40	n.a.		16,34		6	B		588	
Does boat have a list?		No		If "YES" to which side?					
Is crew area asymmetric?		No		If "YES" to which side?					
Is downflooding asymmetric?		No		If "YES" to which side?					
Boat tested:		to Starboard							

**Test Data:**

Mass ident.	Location		Mass (kg)	Total mass (kg)	Lever (m)	Moment (kg-m)	Heel angle (°) P/S	min. freeb'd (m)	
	area	fore & aft						fwd	aft
1			85	85	0,90	76,50			
2			85	170	0,90	76,50			
3			85	255	0,90	76,50			
4			85	340	1,05	89,25			
5			85	425	1,05	89,25			
6			85	510	1,05	89,25			
7			85	595	1,05	89,25			
8			85	680	1,05	89,25			
9			85	765	1,05	89,25			
10			85	850	1,00	85,00			
11			85	935	1,00	85,00			
12			85	1020	1,00	85,00	14,00		
13				1020		0,00			
14				1020		0,00			
15				1020		0,00			
16				1020		0,00			
17				1020		0,00			
18				1020		0,00			
19				1020		0,00			
20				1020		0,00			

total:		$\Sigma$	max. angle	min freeboard		
		1020,00	14,00	0	0,00	
Max. mass of people allowed per above:	1020	hence CL =	12	at	85 kg / person	
Design category given:	B					
Safety Signs Required:	Fig B1:	No	Fig B2:	No	Fig B3:	No

## ISO 12217-1:2017 CALCULATION WORKSHEET No. 5c Simplified procedure for OFFSET LOAD TEST

ZAVRŠNI RAD CONTENDER 34

This method may only be applied by calculation; requirements must be fulfilled for both conditions LC1 and LC2

### Preparation (curves of moments in Nm)

Question	Answer	ref.
Mass and the centre-of-gravity of the boat calculated for conditions LC1 and LC2?	Yes	B.3.2.2
Curves of righting moments calculated according to annex E?	No	B.3.2.3
Crew heeling moment curve calculated with $961 CL (B_C/2 - 0,2) \cos \phi$ or where the crew area includes side decks less than 0,4m wide with $480 CL BC \cos \phi$ ?	No	B.3.2.4

### Test data:

item	symbol	unit	LC1	LC2	ref.
Maximum transverse distance between the outboard extremities of any part of the crew area	$B_C$	m			B.3.2.4 & B.3.1.7
Heel angle at the point of intersection between crew heeling moment curve and the curve of righting moment	$\phi_O$	degrees	0,00	0,00	B.3.2.5
Maximum permitted heel angle	$\phi_{O(R)}$	degrees	16,34		B.3.2.5
Value of downflooding angle	$\phi_{DA}$	degrees			B.3.2.5
Value of minimum freeboard margin at $\phi_O$	$h_F$	m			
Minimum required freeboard margin	$h_{F(R)}$	m	n.a.		6.2.2 table 4
Max. righting moment up to $\phi_{DA}$		Nm	0	0	
Crew heeling moment at $\phi_O$		Nm	0	0	

### Requirements:

Question	Answer	ref.	
Is $\phi_O < \phi_{O(R)}$	Fail	B.3.2.5	
Is $h_F > h_{F(R)}$	n.a.	B.3.2.5	
Is the max. righting moment up to $\phi_{DA} >$ crew heeling moment at $\phi_O$ ?	Fail	Fail	B.3.2.5
Offset load test passed, if all questions above are answered with 'yes' (or n.a.)	Pass/Fail	Fail	B.3.2.5

**ISO 12217-1:2017 CALCULATION WORKSHEET No. 5d curve of righting moment LC1**

ZAVRŠNI RAD CONTENDER 34

insert curve of righting moment in 5° steps in one of following units:

**OFFSET LOAD TEST**

<b>N m</b>	<b>kg m</b>	<b>m</b>	<b>mLC1</b>	<b>6351,859</b>				
<table border="1"> <tr> <td><b>m</b></td> <td>chosen unit</td> </tr> <tr> <td><b>side decks &lt; 0,4m</b></td> <td>crew heeling moment curve (either normal or if side decks smaller 0,4m)</td> </tr> </table>		<b>m</b>	chosen unit	<b>side decks &lt; 0,4m</b>	crew heeling moment curve (either normal or if side decks smaller 0,4m)			
<b>m</b>	chosen unit							
<b>side decks &lt; 0,4m</b>	crew heeling moment curve (either normal or if side decks smaller 0,4m)							

heel angle [°]	insert righting arm / moment [Nm, kg m, m]	righting moment [Nm]	righting moment [kg m]	righting arm Gz [m]	crew heeling moment curve [N m]
0		0	0	0,00	0,00
5		0	0	0,00	0,00
10		0	0	0,00	0,00
15		0	0	0,00	0,00
20		0	0	0,00	0,00
25		0	0	0,00	0,00
30		0	0	0,00	0,00
35		0	0	0,00	0,00
40		0	0	0,00	0,00
45		0	0	0,00	0,00
50		0	0	0,00	0,00

point of intersection of righting moment curve and crew heeling moment curve

$\Phi_c$
----------

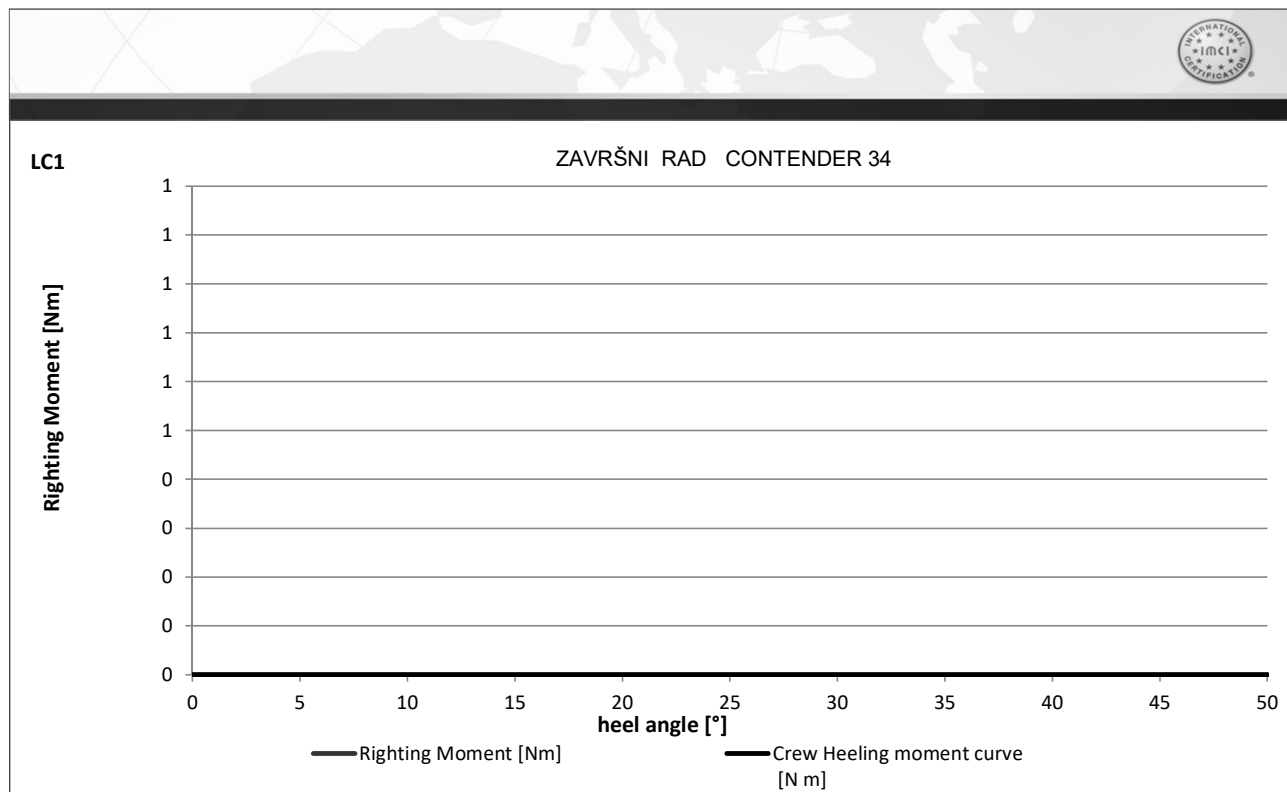

**ISO 12217-1:2017 CALCULATION WORKSHEET No. 5e curve of righting moment LC2**

ZAVRŠNI RAD CONTENDER 34

insert curve of righting moment in 5° steps in one of following units:

**OFFSET LOAD TEST**

*N m                      kg m                      m*

*mLC2*

**5752,599**

chosen unit  
 crew heeling moment curve (either normal or if side decks smaller 0,4m)

heel angle [°]	insert righting arm / moment [Nm, kg m, m]	righting moment [Nm]	righting moment [kg m]	righting arm Gz [m]	crew heeling moment curve [N m]
0		0	0	0,00	0,00
5		0	0	0,00	0,00
10		0	0	0,00	0,00
15		0	0	0,00	0,00
20		0	0	0,00	0,00
25		0	0	0,00	0,00
30		0	0	0,00	0,00
35		0	0	0,00	0,00
40		0	0	0,00	0,00
45		0	0	0,00	0,00
50		0	0	0,00	0,00

point of intersection of righting moment curve and crew heeling moment curve

LC2

ZAVRŠNI RAD CONTENDER 34

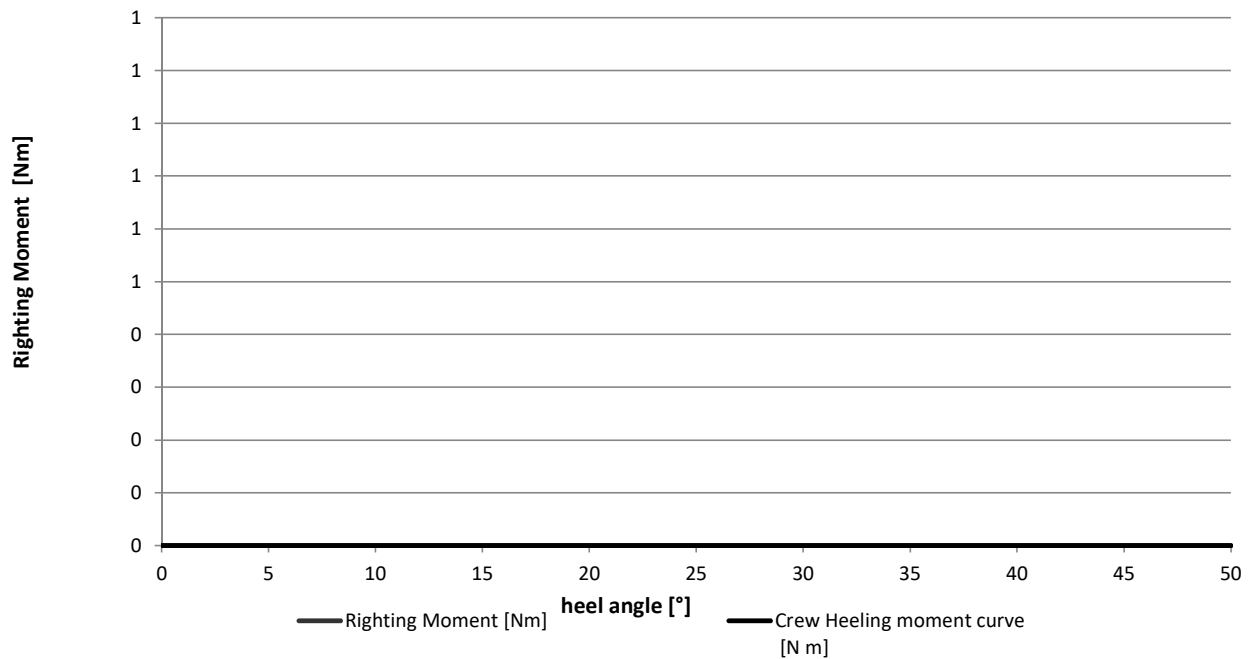



**ISO 12217-1:2017 CALCULATION WORKSHEET No. 6a RESISTANCE TO WAVES+WIND**

ZAVRŠNI RAD CONTENDER 34

**Input data:** **Design categories A and B only**

Item	Symbol	Unit	$m_{LA}$	$m_{MO}$	Ref.
Mass in minimum operating condition	$m_{MO}$	kg		4495,00	3.4.3
Loaded arrival masss	$m_{LA}$	kg	5191,86		3.4.6
Displacement volume ( = $m_{MO}/1025$ or $m_{LA}/1025$ )	$V_D$	m <sup>3</sup>	5,07	4,39	3.4.7
Windage area (of above water profile of boat)	$A_{LV}$	m <sup>2</sup>	8,67	9,18	3.3.7
Windage area to be used (not to be < 0.5 $L_H B_H$ )	$A'_{LV}$	m <sup>2</sup>	15,13	15,13	6.3.2
Length waterline	$L_{WL}$	m	8,70	9,02	3.3.2
Lever between centroids of above and below water areas	$h$	m	0,78	0,78	6.3.2
Draught of canoe body at the mid-point of the waterline length	$T_M$	m	0,637	0,58	
Downflooding angle	$\phi_{DA}$	degrees	34,89	36	3.2.2
Calculation windspeed	$v_W$	m/s	21	21	3.5.1

**ISO 12217-1:2017 CALCULATION WORKSHEET No. 6b RESISTANCE TO WAVES+WIND**

ZAVRŠNI RAD CONTENDER 34

Rolling in beam waves and wind:

Design categories A and B only

Item	Symbol	Unit	m <sub>LA</sub>	m <sub>MO</sub>	Ref.
Second wind heel equilibrium angle		degrees	134,2	130,0	Fig. 6
Least value of $\theta_{DA}$ , $50^{\circ}$ or second wind heel equilibrium angle	$\theta_{A2}$	degrees	34,9	36,0	Fig. 6
Wind heeling moment (1) = $0.53 A'_{LV} h v_W^2$	$M_{W1}$	N-m	2766	2769	6.3.2
Wind heeling moment (2) = $0.30 A'_{LV} (A'_{LV} / L_{WL} + T_M) v_W^2$	$M_{W2}$		4757	4524	
Assumed roll angle Category A = $(25+20/V_D)$	$\theta_R$	degrees	23,9	24,6	6.3.2
Category B = $(20+20/V_D)$					
Area 1 (see fig. 6)	$A_1$	any	6,75	8,08	Fig. 6
Area 2 (see fig. 6)	$A_2$	any	9,20	11,13	Fig. 6
Ratio of $A_2/A_1$		--	1,36	1,38	6.3.2
Is ratio of $A_2/A_1$ greater than or equal to 1.0?	YES / NO		YES	YES	6.3.2

Resistance to waves:

Item	Symbol	Unit	m <sub>LA</sub>	m <sub>MO</sub>	Ref.
Least value of $\theta_{DA}$ , $50^{\circ}$ or second wind heel equilibrium angle		degrees	34,89	35,97	6.3.3
Heel angle when righting moment is maximum	$\theta_{GZMax}$	degrees	55,00	55,00	6.3.3
<b>If <math>\theta_{GZMax}</math> is greater than or equal to <math>30^{\circ}</math></b>					
Max value of righting moment @ $30^{\circ}$ heel?	$RM_{30}$	kN m	28,00	27,15	6.3.3a)
Required value of righting moment		kN m	7,00	7,00	6.3.3a)
Is $RM_{30}$ greater than or equal to required max value?			PASS	PASS	6.3.3b)
Value of righting lever at $30^{\circ}$ = $RM_{30}/(9.806*mass)$	$GZ_{30}$	m	0,550	0,616	3.5.10
Required value of righting lever at $30^{\circ}$		m	0,20	0,20	6.3.3a)
Is $GZ_{30}$ greater than or equal to required max value?			PASS	PASS	6.3.3a)
<b>IF <math>\theta_{GZMax}</math> is less than <math>30^{\circ}</math></b>					
Max value of righting moment	$RM_{MAX}$	kN m	34,98	35,88	6.3.3b)
Required value of $RM_{MAX}$ ( $A = 750/\theta_{GZMax}$ , $B = 210/\theta_{GZMax}$ )		kN m	3,82	3,82	6.3.3b)
Is $RM_{MAX}$ greater than or equal to required max value?			n.a.	n.a.	6.3.3b)
Max value of righting lever = $RM_{MAX}/(9.806*mass)$	$GZ_{MAX}$	m	0,68700	0,81400	3.5.10
Required max value of righting lever = $6/\theta_{GZMax}$		m	n.a.	n.a.	6.3.3b)
Is $GZ_{MAX}$ greater than or equal to the required max value? PASS / FAIL			n.a.	n.a.	6.3.3b)

Design Category given: <b>NB:</b> Boat must have ratio of $A_2/A_1$ greater than or equal to 1.0, and also get PASS twice under resistance to waves.	<b>B</b>
--	----------

**ISO 12217-1:2017 CALCULATION WORKSHEET No. 6c curve of righting moment  $m_{LA}$**

ZAVRŠNI RAD CONTENDER 34

insert curve of righting moment in 5° steps in one of following units:

	<b>N m</b>	<b>kg m</b>	<b>m</b>
chosen unit	m		
chose of $M_w$	MW2		

heel angle [°]	insert Righting Arm/Moment [Nm, kg m, m]	Righting Moment [Nm]	Righting Moment [kg m]	Arm Gz [m]	Wind Heeling moment curve [m]
-25	-0,492	-25.048	-2.554	-0,492	0,0934
-20	-0,412	-20.975	-2.139	-0,412	0,0934
-15	-0,325	-16.546	-1.687	-0,325	0,0934
-10	-0,228	-11.608	-1.184	-0,228	0,0934
-5	-0,121	-6.160	-628	-0,121	0,0934
0	0	0	0	0,000	0,0934
5	0,121	6.160	628	0,121	0,0934
10	0,228	11.608	1.184	0,228	0,0934
15	0,323	16.444	1.677	0,323	0,0934
20	0,409	20.823	2.123	0,409	0,0934
25	0,487	24.794	2.528	0,487	0,0934
30	0,55	28.001	2.856	0,550	0,0934
35	0,6	30.547	3.115	0,600	0,0934
40	0,637	32.431	3.307	0,637	0,0934
45	0,663	33.754	3.442	0,663	0,0934
50	0,679	34.569	3.525	0,679	0,0934
55	0,687	34.976	3.567	0,687	0,0934
60	0,687	34.976	3.567	0,687	0,0934
65		0	0	0,000	0,0934
70		0	0	0,000	0,0934

**area A1 and A2 limits**

	heel degrees		heel degrees	
A1 from	-20,09	to	3,86	below $M_w$
A2 from	3,86	to	34,89	above $M_w$

**point of intersection of righting moment curve and wind heeling moment curve**

$\Phi_w$
3,861

$M_w$	4757	Nm
$M_w$	485,1	kg m
$M_w$	0,093	m
$\Phi_w$	3,86	degrees
$\Phi_{A2}$	34,89	degrees
$\Phi_R$	23,95	degrees

Max $m_{LA}$	0,687	m
heel at GZ max	55,00	degrees

Heeling arm curve  $m_{LA}$

ZAVRŠNI RAD CONTENDER 34

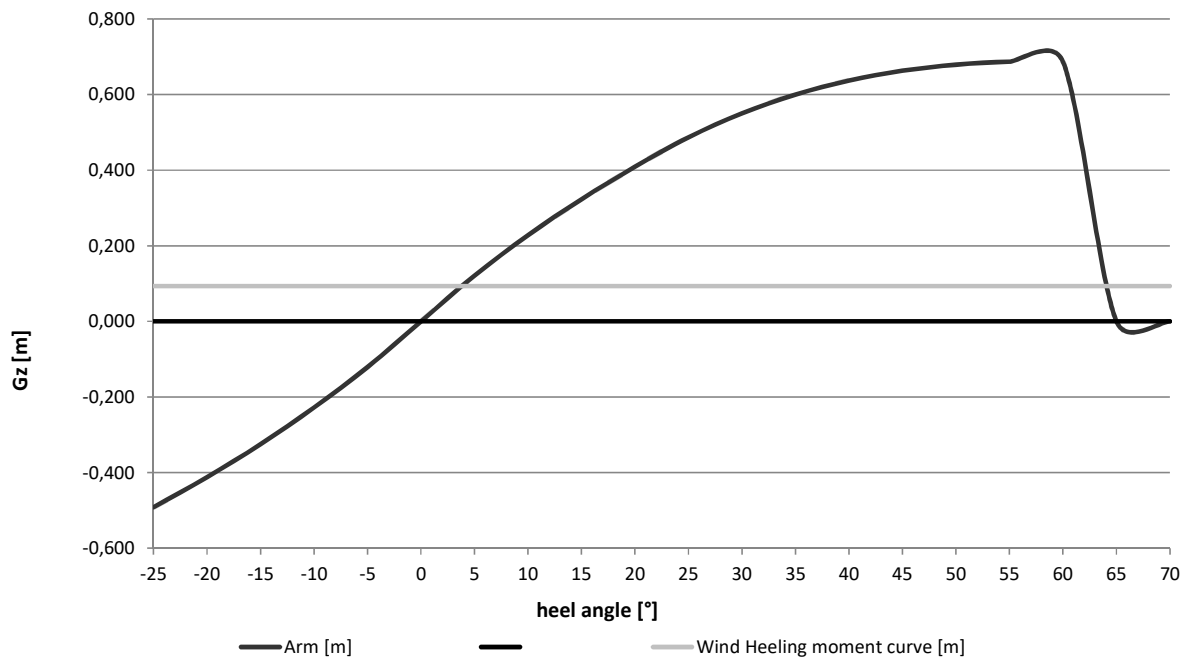

**ISO 12217-1:2017 CALCULATION WORKSHEET No. 6d curve of righting moment  $m_{MO}$**

ZAVRŠNI RAD CONTENDER 34

insert curve of righting moment in 5° steps in one of following units:

chosen unit	<b>N m</b>	<b>kg m</b>	<b>m</b>
chose of $M_w$	<b>m</b>		
	<b>MW2</b>		

heel angle[°]	insert Righting Arm/Moment [Nm, kg m, m]	Righting Moment [Nm]	Righting Moment [kg m]	Arm Gz [m]	Wind Heeling moment curve [m]
-25	-0,542	-23.890	-2.436	-0,542	0,1026
-20	-0,46	-20.276	-2.068	-0,460	0,1026
-15	-0,369	-16.265	-1.659	-0,369	0,1026
-10	-0,265	-11.681	-1.191	-0,265	0,1026
-5	-0,141	-6.215	-634	-0,141	0,1026
0	0	0	0	0,000	0,1026
5	0,141	6.215	634	0,141	0,1026
10	0,265	11.681	1.191	0,265	0,1026
15	0,369	16.265	1.659	0,369	0,1026
20	0,459	20.232	2.063	0,459	0,1026
25	0,54	23.802	2.427	0,540	0,1026
30	0,616	27.152	2.769	0,616	0,1026
35	0,685	30.193	3.079	0,685	0,1026
40	0,741	32.662	3.331	0,741	0,1026
45	0,781	34.425	3.511	0,781	0,1026
50	0,805	35.483	3.618	0,805	0,1026
55	0,814	35.879	3.659	0,814	0,1026
60	0,81	35.703	3.641	0,810	0,1026
65		0	0	0,000	0,1026
70		0	0	0,000	0,1026

**area A1 and A2 limits**

A1 from	heel degrees	-20,92	to	heel degrees	3,64	below $M_w$
A2 from	heel degrees	3,64	to	heel degrees	35,97	above $M_w$

**point of intersection of righting moment curve and wind heeling moment curve**

$\Phi_w$	3,639
----------	-------

$M_w$	4524	Nm
$M_w$	461,3	kg m
$M_w$	0,103	m
$\Phi_w$	3,64	degrees
$\Phi_{A2}$	35,97	degrees
$\Phi_R$	24,56	degrees

Max $m_{MO}$	0,814	m
heel at GZ max	55,00	degrees

**INTERNATIONAL MARINE CERTIFICATION INSTITUTE**  
INTERNATIONAL NON-PROFIT ASSOCIATION



Heeling arm curve  $m_{MO}$

ZAVRŠNI RAD CONTENDER 34

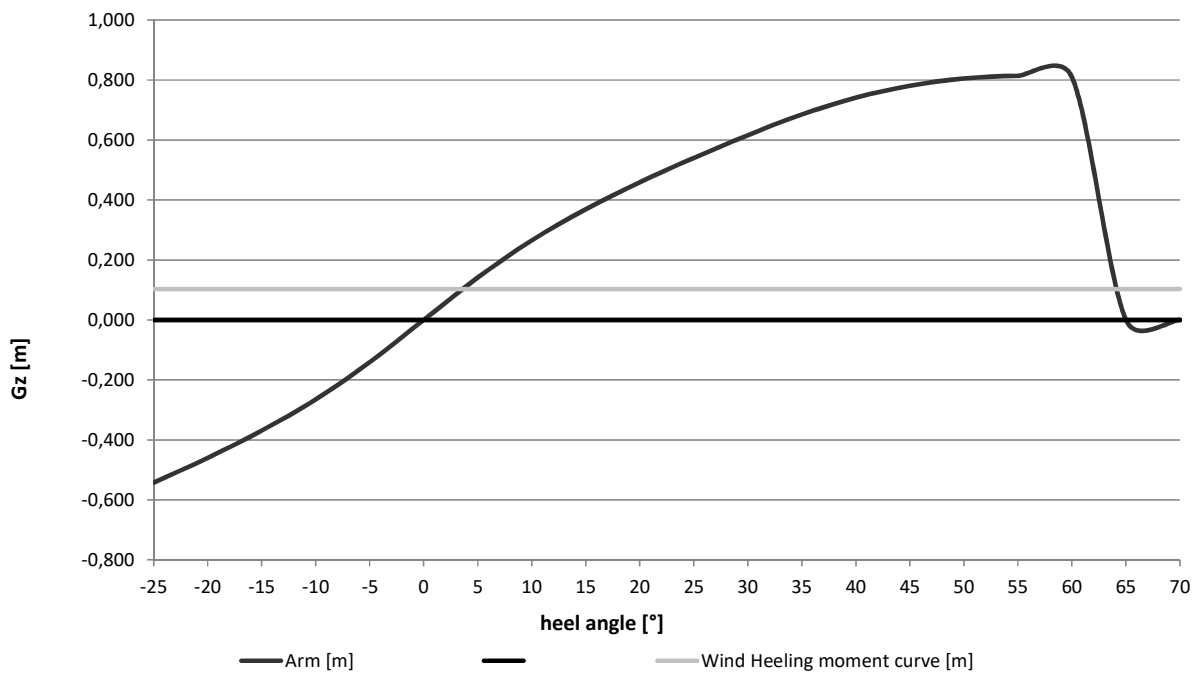

ZAVRŠNI RAD CONTENDER 34

**NB: This sheet is to be completed for both Minimum Operating and Loaded arrival condition**

**Initial check:** **Design Categories C and D only**

Item	Symbol	Unit	m <sub>LA</sub>	m <sub>MO</sub>	Ref.
Windage area (NOT subject to minimum of 0.5 L <sub>H</sub> B <sub>H</sub> )	A <sub>LV</sub>	m <sup>2</sup>		9,18	3.3.7
Length of Hull	L <sub>H</sub>	m	10,40	10,40	3.3.2
Beam of hull	B <sub>H</sub>	m	2,91		3.3.3
Ratio A <sub>LV</sub> /(L <sub>H</sub> B <sub>H</sub> ) at m <sub>MO</sub>		-----	0,30		
Is ratio A <sub>LV</sub> /(L <sub>H</sub> B <sub>H</sub> ) equal to or greater than 0.5?			No		6.4
If answer is NO, no other assessment is required.					

**Calculation of wind heeling moment:**

Item	Symbol	Unit	m <sub>LA</sub>	m <sub>MO</sub>	Ref.
Length of waterline	L <sub>WL</sub>	m			3.3.2
Draught at the mid-point of L <sub>WL</sub>	T <sub>M</sub>	m			6.3.2
Lever between centroids of above and below water areas	h	m			6.3.2
Calculation wind speed	v <sub>W</sub>	m/s	n.a.		3.5.1
Wind heeling moment M <sub>W1</sub> = 0.53 A <sub>LV</sub> h v <sub>W</sub> <sup>2</sup>	M <sub>W</sub>	Nm	#####	#####	6.4.2
Wind heeling moment M <sub>W2</sub> = 0.3 A <sub>LV</sub> (A <sub>LV</sub> / L <sub>WL</sub> + T <sub>M</sub> ) v <sub>W</sub> <sup>2</sup>	M <sub>W</sub>	Nm	#DIJ/0!	#DIJ/0!	6.4.2

**Angle of heel due to wind:**

Item	Symbol	Unit	m <sub>LA</sub>	m <sub>MO</sub>	Ref.
FROM RIGHTING MOMENT CURVE: angle of heel due to wind	φ <sub>W</sub>	degrees	3,86	3,64	6.4.3
OR ALTERNATIVELY: wind heeling moment M <sub>W</sub> divided by 9.806	M <sub>W</sub>	kg.m	#####	#####	
Angle of heel due to wind when moment above applied	φ <sub>W</sub>	degrees			6.4.3
Maximum permitted angle of heel during offset load test (from worksheet 5b)	φ <sub>O(R)</sub>	degrees	16,34		6.2.3
Downflooding angle	φ <sub>DA</sub>	degrees	34,89	35,97	3.2.2
Maximum permitted angle of heel due to wind = lesser of 0.7φ <sub>O(R)</sub> and 0.7φ <sub>DA</sub>		degrees	11,4	11,4	6-4.3
Is angle of heel due to wind less than permitted value?			Pass	Pass	6.4.3
<b>Design Category possible on wind heeling =</b>					

**ISO 12217-1:2017 CALCULATION WORKSHEET No. 8**

ZAVRSNI RAD CONTENDER 34

**NB: This sheet is to be completed for the Loaded Arrival Condition.**  
Please submit multiple copies of this page if applicable

**calculation required**

	Recess	1	Ref.
<b>Further exemptions according to 6.5.1</b>			
Angle of vanishing stability > 90° ?	YES/NO	Yes	6.5.1a)
Over at least 35% of the periphery is the depth of the recess less than 3% of the max. breadth of the recess (e.g. toe rails, low bulwarks)	YES/NO	Yes	6.5.1b)
At least 5% of the bulwark area positioned within the lowest 25% of the bulwark height drains overboard and the bulwark height is less than 12,5% of the maximum breadth of the recess <i>(attention, req. 1) and 2) below must get also a "Yes" to fullfill all requirements)</i>	YES/NO	Yes	6.5.1c)
Unobstructed drainage area from the recess on each side of the boat centreline	m <sup>2</sup>		6.5.1d)
Volume of the recess to the recess retention level	m <sup>3</sup>		
Drainage area per side (m <sup>2</sup> ) divided by recess volume (m <sup>3</sup> )			6.5.1d)
Height position of drainage area (lowest 25% / lowest 50% / full depth)			6.5.1d)
Requirements of 6.5.1.d) fulfilled? <i>(attention, req. 1) and 2) below must get also a "Yes"</i>	YES/NO		6.5.1d)
1) the lower edge of the drainage openings are not more than 10 mm above recess sole height for at least 70 % of the width of each opening?	YES/NO	Yes	6.5.1 c) & d)
2) If drainage area is provided by an open or partially open transom, are the openings extend to the outboard sides of the recess sole on both sides?	YES/NO	Yes	6.5.1 c) & d)
Is recess exempt from size limit? If "yes", no further calculation required.	Yes		6.5.1

**Calculation methods:**

Item	Symbol	Unit	Value	Ref.
			Recess 1	
<b>SIMPLIFIED METHOD:</b> Use 1), 2) or 3) below.				
Average freeboard to loaded waterline at aft end of recess	$F_A$	m		6.5.2.1
Average freeboard to loaded waterline at sides of recess	$F_S$	m		6.5.2.1
Average freeboard to loaded waterline at forward end of recess	$F_F$	m		6.5.2.1
Waterline length at mLA	$L_{WL}$	m		
Waterline breadth at mLA (for multihulls insert max. beam waterline $B_{WLmax}$ acc. to ISO 8666)	$B_{WL}/B_{WLmax}$	m		ISO 8666 4.3.4/5
Maximum length of recess at the retention level (see 3.5.11)	$l$	m		6.5.2.4
Maximum breadth of recess at the retention level (see 3.5.11)	$b$	m		6.5.2.4

- In case of assymetric recesses (e.g. bowrider, centercockpits, ...), please insert length and breadth of each area below; this allows a more exact calculation using simplified method 1) or 2)

	max. length	max. breadth	Unit	% loss GMT (option 1)	% loss GMT (option 2)	Ref.
Maximum length and breadth of recess part A			m			6.5.2.2/3
Maximum length and breadth of recess part B			m			6.5.2.2/3
Maximum length and breadth of recess part C			m			6.5.2.2/3
Maximum length and breadth of recess part D			m			6.5.2.2/3
Maximum length and breadth of recess part E			m			6.5.2.2/3
Maximum length and breadth of recess part F			m			6.5.2.2/3
Maximum length and breadth of recess part G			m			6.5.2.2/3
Maximum length and breadth of recess part H			m			6.5.2.2/3
Maximum length and breadth of recess part I			m			6.5.2.2/3

to be continued on page 2



**ISO 12217-1:2017 CALCULATION WORKSHEET No. 8**

page 2

	Symbol	Unit	Value	Ref.
			Recess 1	
Average freeboard to recess periphery $= (F_A + 2F_S + F_F) / 4$	$F_R$	m	0	6.5.2.1
Category A permitted percentage loss in metacentric height $(GM_T) = 250 F_R / L_H$			n.a.	6.5.2.1
Category B permitted percentage loss in metacentric height $(GM_T) = 550 F_R / L_H$			0	6.5.2.1
Category C permitted percentage loss in metacentric height $(GM_T) = 1\,200 F_R / L_H$			n.a.	6.5.2.1

SIMPLIFIED METHOD: Use 1), 2) or 3) below.			Recess 1	
<b>1) Loss of <math>GM_T</math> used?</b>				6.5.2.1
Second moment of area of free-surface of recess	$SMA_{RECESS}$	m <sup>4</sup>	0	6.5.2.2
Metacentric height of boat at $m_{LA}$	$GM_T$	m		6.5.2.2
Calculated percentage loss in metacentric height	$(GM_T) = \frac{102\,500 \times SMA_{RECESS}}{m_{LA} \times GM_T}$			6.5.2.2
<b>2) Second moment of areas used?</b>				6.5.2.1
Second moment of area of free-surface of recess	$SMA_{RECESS}$	m <sup>4</sup>	0	6.5.2.3
Second moment of area of waterplane of boat at $m_{LA}$	$SMA_{WP}$	m <sup>4</sup>	0	6.5.2.3
Calculated percentage loss in metacentric height	$(GM_T) = \left( \frac{245 \times SMA_{RECESS}}{SMA_{WP}} \right)$			6.5.2.3
<b>3) Recess dimensions used?</b>				6.5.2.1*
Maximum length of recess at the retention level (see 3.5.11)	$l$	m	0	6.5.2.4
Maximum breadth of recess at the retention level (see 3.5.11)	$b$	m	0	6.5.2.4
Calculated percentage loss in metacentric height	$(GM_T) = 270 \left( \frac{l \times b^3}{L_H \times B_H^3} \right)^{0.7}$			6.5.2.4

<b>Requirement:</b> from results above, applied design category possible?	<b>Fail</b>	6.5.2.1
---	-------------	---------

DIRECT CALCULATION METHOD used?				
Percentage full of water = $60 - 240 F/L_H$				6.5.3
Wind heeling moment for intended design category	$M_W$	N·m	2765,779446	6.5.3b)
Crew heeling moment at $\phi_{GZmax}$		N·m		6.5.3c)
Maximum swamped righting moment up to least of $\phi_D$ , $\phi_V$ or $50^\circ$		N·m		6.5.3d)
Required margin of righting moment over heeling moment		N·m	5191,859	6.5.3d)
Actual margin of righting moment over heeling moment		N·m		6.5.3d)

<b>Applied design category possible?</b>	<b>n.a.</b>	
--	-------------	--

Design category C boats using option 6				
Recess entirely contained within LH/2 of the bow ?				6.5.4
Volume to retention level (see 3.5.9) larger than $(L_H B_H F_M) / 40$ ?				6.5.4
If both questions are answered with 'yes' check requirements below:				
Recess is quickdraining recess either overboard or in the bilge?				6.5.4
Design category possible			<b>n.a.</b>	6.5.4

**ISO 12217-1:2017 CALCULATION WORKSHEET No. 9 Habitable Multihulls & Motor Sailers**

ZAVRŠNI RAD CONTENDER 34

**Habitable Multihulls**

Is boat habitable multihull acc. to cl. 3.1.8 ?

No

**NB: Boats complying with the other requirements of this standard for design categories A, B or D are not considered to be susceptible to inversion**

**Boats of design category C:**

Item	Symbol	Unit	Value	Ref.
Beam of hull	$B_H$	m	2,91	3.3.3
Volume of displacement in minimum operation condition	$V_D$	m <sup>3</sup>	4,39	3.4.7
Cube root of volume of displacement in $m_{MO}$	$V_D^{1/3}$	m	1,64	
Height of centroid of $A_{LV}$ above $m_{MO}$ waterline	$h_C$	m	0,45	6.6.3
Actual value of $h_C / B_H$	$h_C / B_H$	/	0,15	
Boat considered to be susceptible to inversion if either (10) or (11)				6.6.3
(10) when $V_D^{1/3} > 2,6$ and $h_C / B_H > 0,572$			n.a.	6.6.3
(11) when $V_D^{1/3} \leq 2,6$ and $h_C / B_H > 0,22 V_D^{1/3}$			n.a.	6.6.3
<b>Is boat susceptible to inversion in design category C?</b>			No	
If 'Yes', boat must comply with ISO 12217-2, cl. 7.12 and cl. 7.13 (relevant ISO 12217-2 worksheets to be used)				6.6.1
Boat complies with ISO 12217-2, cl. 7.12 buoyancy when inverted?		Yes / No		6.6.1a)
Boat complies with ISO 12217-2, cl. 7.13 escape after inversion?		Yes / No		6.6.1b)

**Motor Sailer**

Is boat defined as "non-sailing" ?

Yes

Is boat fitted with mast and sails?

No

**NB: Only applicable to non-sailing boats with sails of design cat A or B**

Item	Symbol	Unit	Value	Ref.
Sum of the windage area as defined in 3.3.7 plus the actual profile area, including overlaps, of the largest sail plan suitable for windward sailing in true winds of more than 10 kn to 12 kn (5,1 m/s to 6,2 m/s) and supplied or recommended by the builder as standard;	$A_{max}$	m <sup>2</sup>		6.7.2
Vertical distance between the geometric centres of $A_{max}$ and underwater profile area	$h$	m		6.7.2
Wind speed, 18 m/s for category A and 14 m/s for category B	$v_W$	m/s	14,00	6.7.2
Heeling moment due to wind ( $M_W = 0,53 A_{max} h v_W^2$ )	$M_W$	Nm	0	6.7.2
Maximum righting moment of the boat in $m_{LA}$ up to $\Phi_{DA}$	$RM_{max1}$	Nm	30.038	3.5.11
<b>Wind heeling moment <math>M_W</math> less than 50% of <math>RM_{max1}</math> ?</b>			Pass	6.7.2

**ISO 12217-1:2017 CALCULATION WORKSHEET No.10 FLOTATION TEST**

ZAVRŠNI RAD CONTENDER 34

Annexes E and F assumed Crew Limit (CL) = 6  
*theoretical calculation method used, calculation attached?*

**Preparation**

Item	Unit	Response	Ref.
Mass equal to 25% of dry stores and equipment added?			F.2 a)
Inboard or outboard engine fitted?			
If inboard fitted, correct engine replacement mass fitted?			F.2 d)
Assumed outboard engine power?	Kw	600	F.2 c)
Mass fitted to represent outboard engine, controls, and battery.	kg	625	Tables F.1 and F.2
Portable fuel tanks removed and/or fixed tanks are filled?			F.2 f)
Cockpit drains open and drain plugs are fitted?			F.2 g)
Void compartments which are not air tanks are opened?			F.2 i)
Number of integral air tanks required to be open?			Table F.3
Type of test weights used: lead, 65/35 brass, steel, cast iron, aluminum			F.3.2
Material factor <i>d</i>		Failure	Table F.4

**Swamped stability test:**

Item	Unit	Response	Ref.
Dry mass of test weights = $6dCL$ but $\geq 15d$	kg	#####	Table F.6
Test weight hung from gunwale each of four positions in turn?			F.3.1
5 min after swamping, boat heels less than $45^{\circ}$			F.3.4 + F.3.5

**Swamped buoyancy test:**

Item	Unit	Response	Ref.
<b>Load test:</b>			F.4
Design Category assessed		B	
Dry mass of test weights used	kg	#####	Table F.5
5 min after swamping, boat floats approximately level with more than 2/3 of periphery above water?			F.4.3

**Swamped buoyancy test (for design cat B only)**

Item	Unit	Response	Ref.
Total buoyant volume according to Iso 6185-4:2011, clause 7.6.1 and 7.6.2	m <sup>3</sup>		F.4.4; ISO 6184-4
$1,33 m_{LDC} / 1000$	t	8,36817247	3.4.5
Total buoyant volume > $1,33 m_{LDC} / 1000$ ?		n.a.	F.4.4

**Flotation material and elements:**

Item	Response	Ref.
All flotation elements comply with all requirements?		Table G.1

**Design Category given:** NB: boat must obtain PASS in all above tables **Fail**

**ISO 12217-1:2017 CALCULATION WORKSHEET No. 11 DETECTION + REMOVAL OF WATER**

ZAVRŠNI RAD CONTENDER 34

Item	response	Ref.
The internal arrangement facilitates the drainage of water to bilge suction point(s), to a location from which it can be bailed rapidly, or directly overboard?	Yes	6.9.1
Is boat provided with a means of removing water from the bilges in accordance with 15083?	Yes	6.9.2
Table 2 option used for assessment:	1	6.9.3; 5.4 table 2
Can water in boat be detected from helm position?	Yes	6.9.3
Methods used: direct visual inspection		6.9.3
transparent inspection panels		6.9.3
bilge alarms		6.9.3
indication of the operation of automatic bilge pumps		6.9.3
other means (specify):		6.9.3

ISO 12217-1:2017 en220801

CALCULATION WORKSHEET No.12

SUMMARY

Design Description:	ZAVRŠNI RAD CONTENDER 34		
Design Category intended:	B	Crew Limit:	6
Date:	2023-09-12		

Sheet	Item	Symbol	Unit	Value		
	<b>Length of hull:</b> (as in ISO 8666)	$L_H$	m	10,40		
	<b>Length of waterline in loaded arrival condition</b>	$L_{WL}$	m	8,70		
	<b>Beam of hull:</b> (as in ISO 8666)	$B_H$	m	2,91		
	<b>Masses:</b>					
1	Empty craft mass	$m_{EC}$	kg	2705		
	Maximum load	$m_L$	kg	2027		
	Maximum load for the builder's plate acc. to ISO 14945:2021	$m_{MBP}$	kg	708		
	Number of portable tanks included in builder's plate weight			0		
	Light craft condition mass	$m_{LC}$	kg	4265		
	Maximum Loaded condition mass = $m_{LC} + m_{ML}$	$m_{LDC}$	kg	6292		
	Loaded arrival condition mass	$m_{LA}$	kg	5192		
	Minimum operating condition mass	$m_{MO}$	kg	4495		
1	<b>Is boat sail or non-sail?</b>	SAIL/NON-SAIL		NON-SAIL		
2	<b>Option selected:</b>			1		
3	<b>Downflooding openings:</b>	Are all requirements met?			Pass	
		Watertightness test for closing appliances done successful?			Pass	
		Exemptions ok or openings considered as possible downflooding openings?			n.a.	
3	<b>Downflooding angle:</b> (Categories A and B only)	degrees	Required	$m_{MO}$	$m_{LA}$	Pass/Fail
		degrees	> 29	35,97	34,89	Pass
3 & 4	<b>Downflooding height:</b>	Worksheet employed for basic height		exempted acc. to 6.1.2.1?		No
	basic requirement	m	0,61		0,84	Pass
	reduced height for small openings (only using figures)	m	0,46		0,84	Pass
	reduced height at outboard (options 3, 4, 6 only)	m	n.a.		0,00	n.a.
	increased height at bow (options 3, 4, 6 only)	m	n.a.		0,00	n.a.
5	<b>Off-set load test:</b>	Unit	Required	Actual		Pass/Fail
	Testing for least stability: maximum heel angle	degrees	< 16,34		14,00	Pass
	Testing for least freeboard: heeled freeboard margin	m	n.a.		0,00	n.a.
	Maximum crew limit for stability			6		
	Maximum crew limit for freeboard			6		
6	<b>Resistance to waves and wind:</b> (options 1, 3) at $m_{LA}$ and $m_{MO}$					
	<b>Rolling in beam waves and wind:</b> ratio $A_2/A_1$	-	$\geq 1.0$	1,38	1,36	Pass
	Resistance to waves: value of $\sigma_{GZMax}$	degrees	---	55,00	55,00	
	value of $RM_{30}$ or $RM_{MAX}$	kNm	7	28,00	27,15	Pass
	value of $GZ_{30}$ or $GZ_{MAX}$	m	0,2	0,55	0,62	Pass

7	<b>Heel due to wind:</b> (options 2,4,5,6) at $m_{LA}$ and at $m_{MO}$					n.a.
	at $m_{MLA}$ : heel angle due to wind	degrees	<		3,86	n.a.
	if required at $m_{MO}$ : heel angle due to wind	degrees	<	3,64		n.a.
8	<b>Recess size:</b> (options 1 and 2 except category D)					
	Simplified method: max reduction in $GM_T$	%	≤		0	n.a.
	Direct calculation: margin righting moment over heeling moment	N m	≥		5191,859	n.a.
	For category C boats using option 6; drainage requirements for recesses entirely contained within LH/2 of the bow are fulfilled?					n.a.
9	<b>Habitable Multihulls:</b> Is Category C boat vulnerable to inversion?				Yes / No	
	Complies with Part 2 clause 7.12 for inverted buoyancy?				Pass / Fail	
	Complies with Part 2 clause 7.13 for means of escape?				Pass / Fail	
9	<b>Motor Sailers</b> Complies with requirement for excess of $RM_{MAX}$ over $M_W$ ?				Pass / Fail	
10	<b>Flotation test:</b> (options 3 and 4 only) All preparations completed?				Yes / No	n.a.
	<b>Swamped stability:</b> 5 min after swamping, does boat heel less than 45°?				Pass / Fail	n.a.
	<b>Load test:</b> 5 min after swamping, does boat float level with 2/3 periphery showing?				Pass / Fail	n.a.
	<b>Swamped buoyancy,</b> for boats using option 3: Total buoyant volume > $1,33 m_{LDC} / 1000$ ?				Pass / Fail	n.a.
	<b>Flotation elements:</b> do all elements comply with all the requirements?				Pass / Fail	n.a.
11	<b>Detection &amp; removal of water</b> are all requirements satisfied?				Yes / No	Yes
NB: Boat must pass all requirements applicable to selected option to be given intended Design Category.						
<b>Design Category given:</b>		<b>B</b>	Assessed by:		<b>Petra Lukačić</b>	

- Documentation of downflooding opening / closing appliance (photo/drawing) attached?
- If applicable, cockpit calculation according to ISO 11812 attached ?
- If applicable, curve of righting moments in  $m_{MO}$  and  $m_{LA}$  attached ?
- Appropriate add. information attached (e.g. photos, drawings,...) ?
- If applicable, ISO 12216 calculation attached?

Signature: \_\_\_\_\_