

# Sklopni i radionički crteži karatkerističnih djelova turbopuhala

---

**Mudri, Staša**

## Supplement / Prilog

Publication year / Godina izdavanja: **2024**

Permanent link / Trajna poveznica: <https://um.nsk.hr/um:nbn:hr:190:314556>

Rights / Prava: [Attribution 4.0 International](#)/[Imenovanje 4.0 međunarodna](#)

Download date / Datum preuzimanja: **2024-11-06**



Repository / Repozitorij:

[Repository of the University of Rijeka, Faculty of Engineering](#)



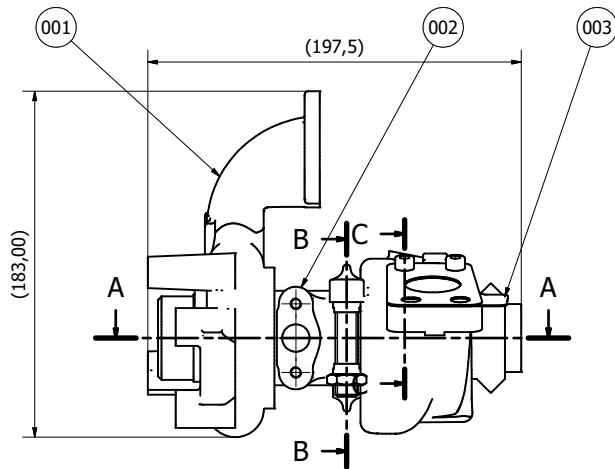
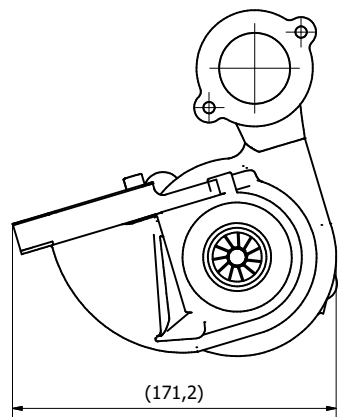

A-A (1 : 1)

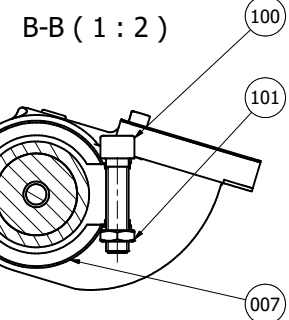
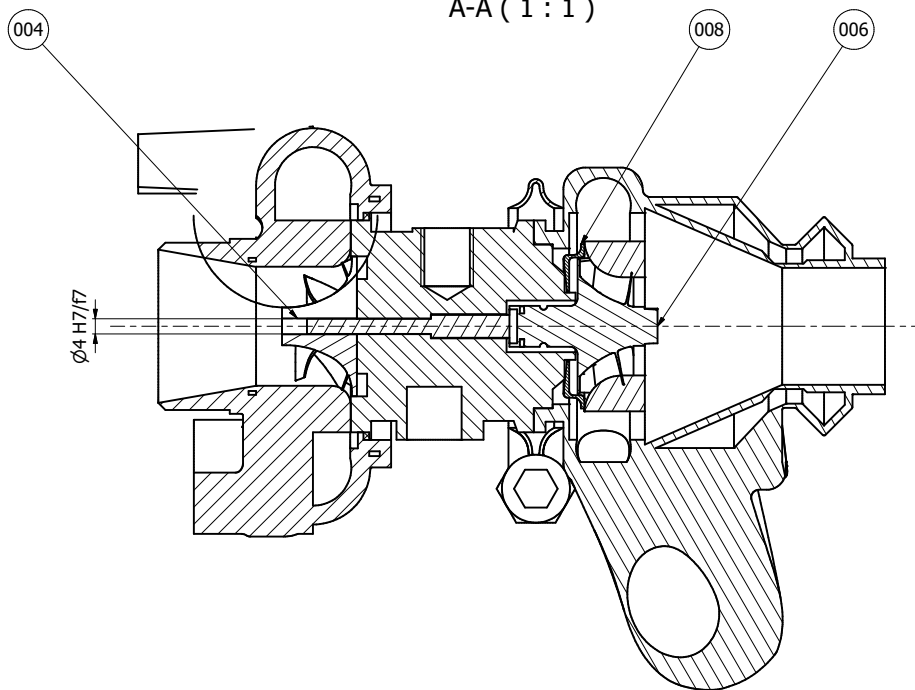

C-C (1 : 2), rotirano

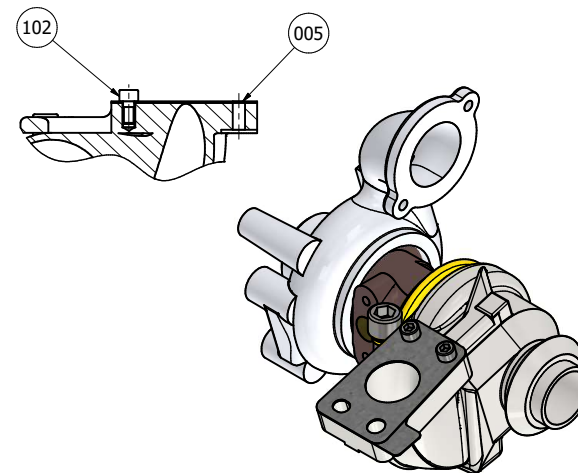

POPIS DIJELOVA			
Pozicija	Količina	Naziv dijela	Materijal
001	1	Kuciste_kompresora	Aluminij
002	1	Kuciste_lezaja	Nehrđajući čelični ljev
003	1	Kuciste_turbine	Nehrđajući čelični ljev
004	1	Rotor_kompresora	Aluminij
005	1	Brтва	Nehrđajući čelik
006	1	Spoj_vratila_i_rotora	Aluminij
007	1	Spojnica	Nehrđajući čelik
008	1	Zastitni_poklopac	Aluminij
100	1	DIN 912 - M12 x 50	Steel, Mild
101	1	ISO 4035 - M12	Stainless Steel, 440C
102	2	ISO 4762 - M6 x 12	Stainless Steel, 440C

Naziv sklopa: <b>Turbopuhalo</b>	Datum	Ime i prezime Staša Mudri	Potpis	Prog. br.: 1	Mjerilo: 1 : 2
	Nacrtao:			List/Listova 1/1	
Broj skl. crteža: 1	Provjerio:			Šk. god.:	A2
	Odobrio:			2023./24.	
Tehnički fakultet Rijeka	Naziv dijela: Sklopni nacrt			Broj crteža: 1 / 1	

ISO DOSJEDI	
Ø4 H7/f7	+0,034 -0,010



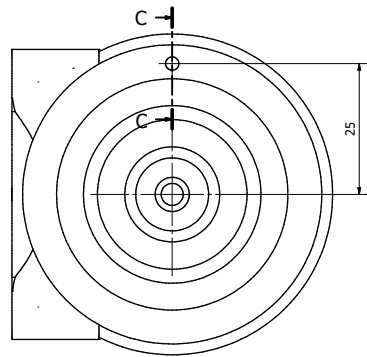
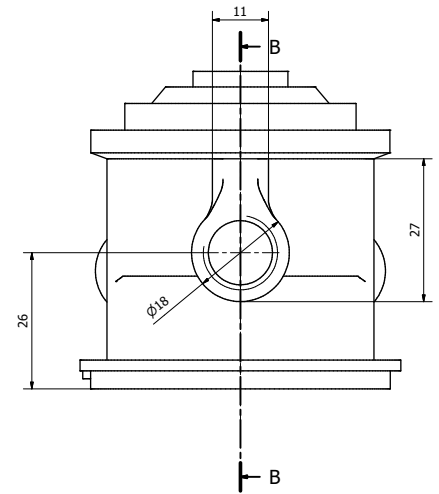
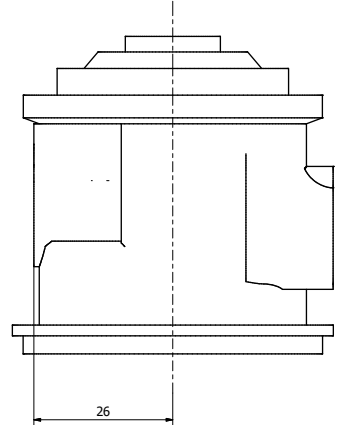
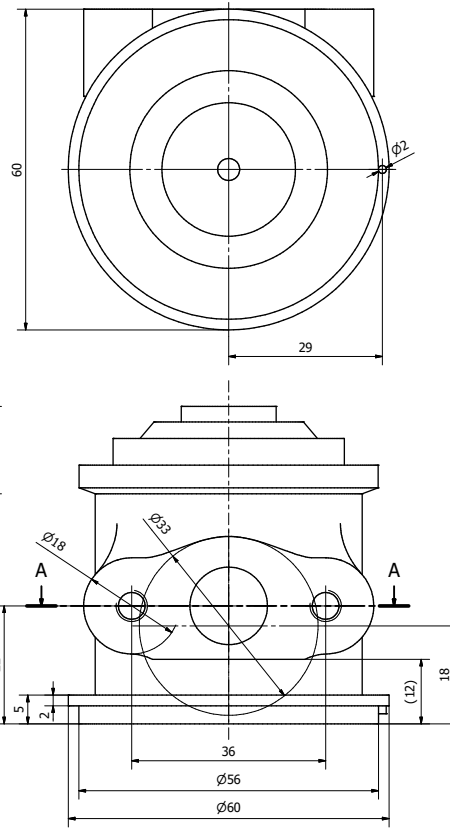
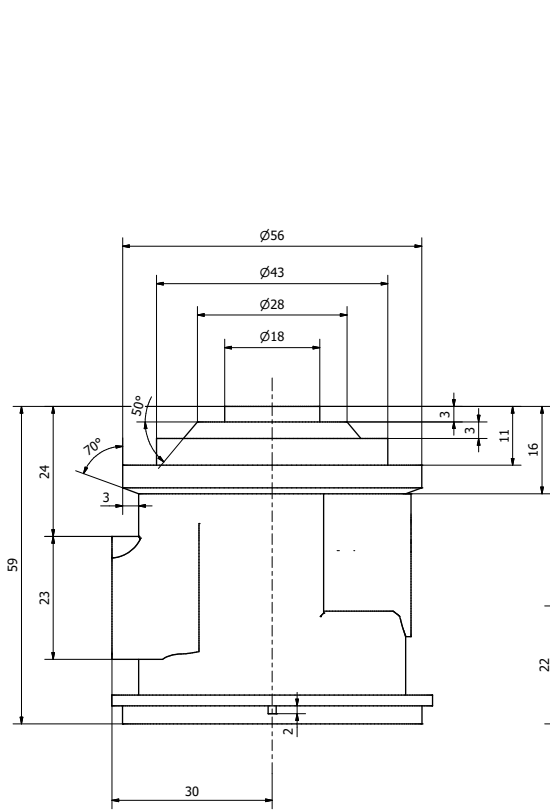

C-C (2 : 1)

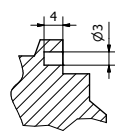

A-A (2 : 1)

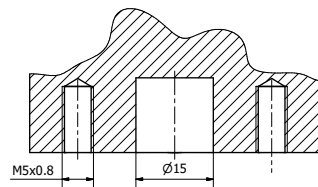

B-B (2 : 1)

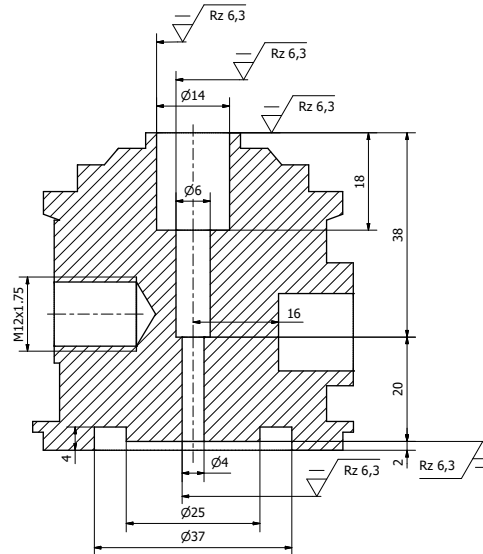

(1 : 1)

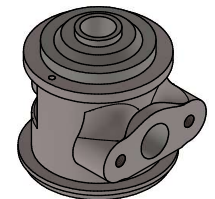

Ime i prezime: Stasa Mudri	Obrada površine: Rz 25	Materijal: Nehrđajući čelični lijev	Mjerilo: 2 : 1
Tehnički fakultet Rijeka	Datum: 03.09.2024.	Broj crteža: 1	A1
Naziv pozicije: Kuciste_lezaja			

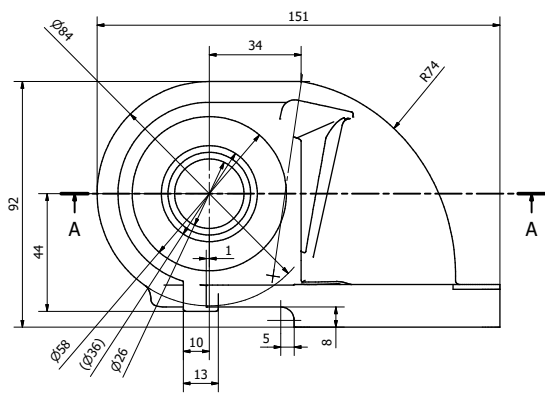
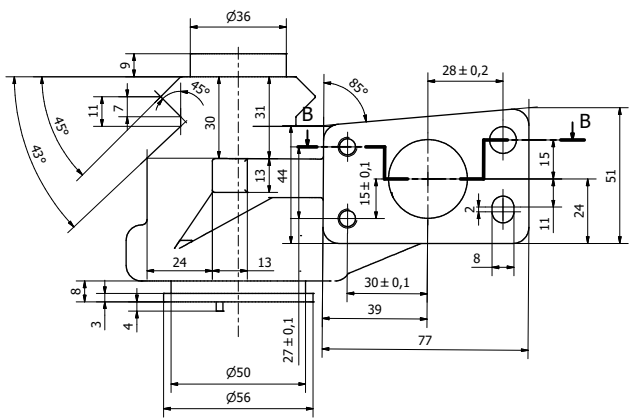
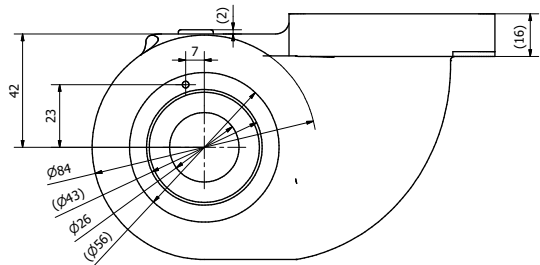

A-A (1:1)

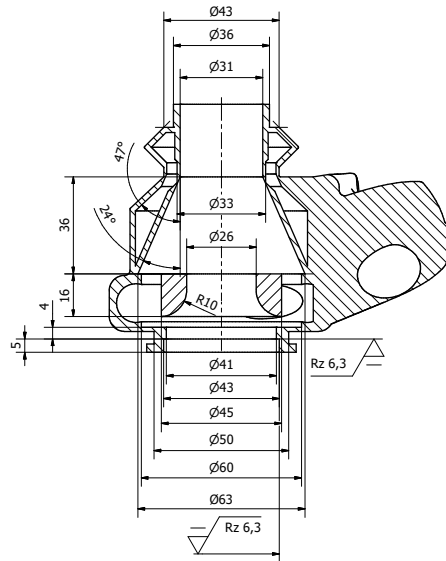

B-B (1:1)

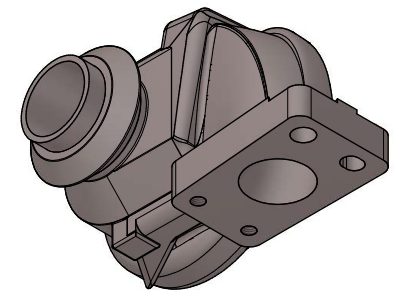
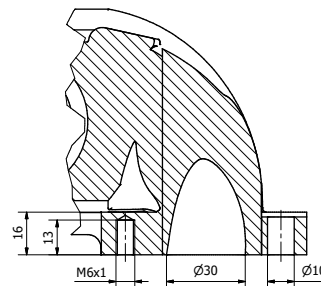

- sva nekotirana zaobljenja izvesti s R = 1

Ime i prezime: Stasa Mudri	Obrada površine: Rz 25	Materijal: Nehrđajući čelični lijev	Mjerilo: 1 : 1
Tehnički fakultet Rijeka	Datum: 03.09.2024.	Broj crteža: 1	A1
Naziv pozicije: Kuciste turbine			

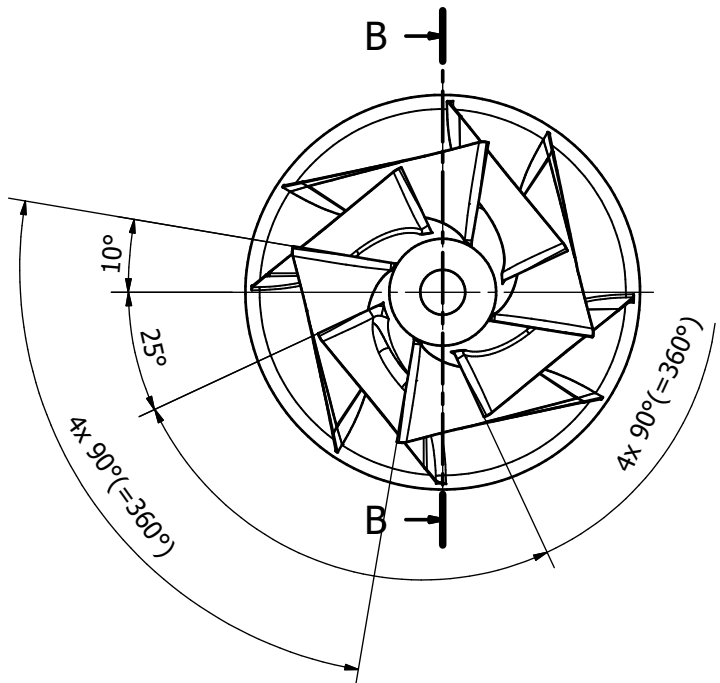

A-A (2 : 1)

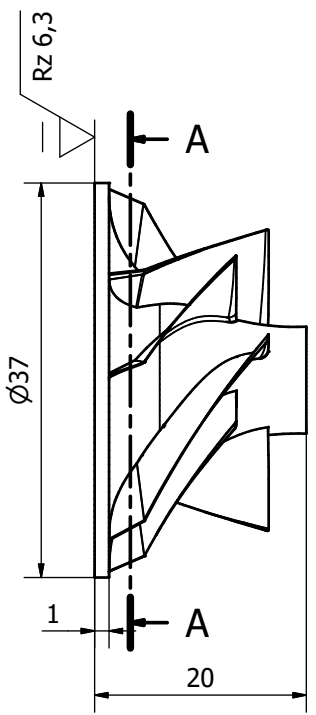
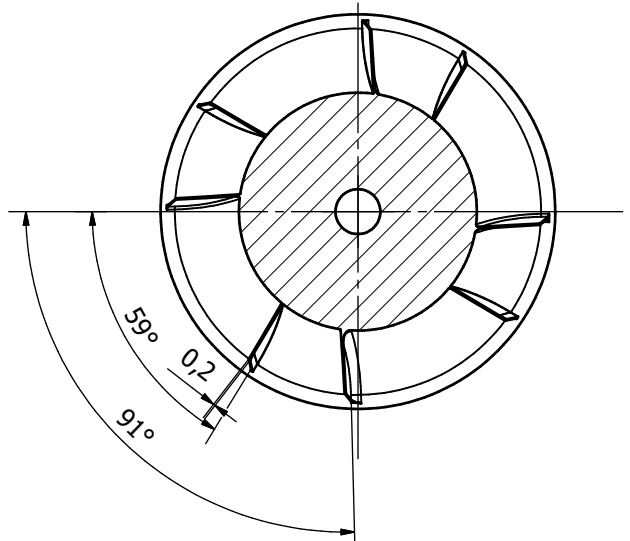

B-B (2 : 1)

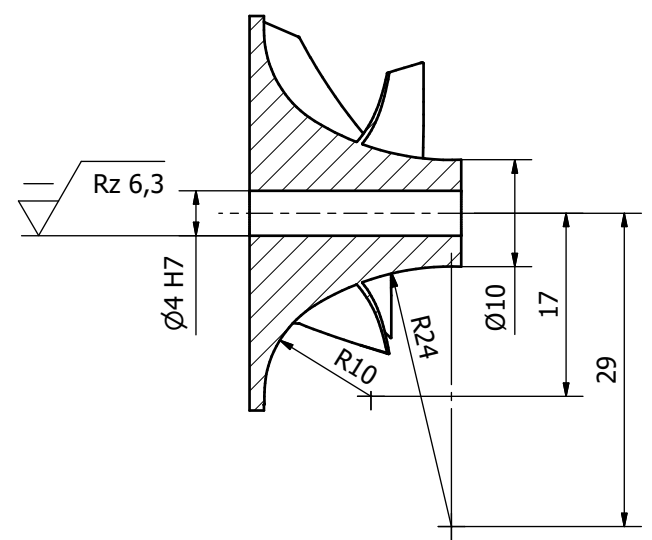

(1 : 1)

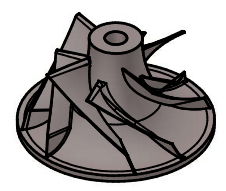

Ime i prezime: Staša Mudri	Obrada površine: Rz 25	Materijal: Aluminij	Mjerilo: 2 : 1
	Datum: 03.09.2024.		Broj crteža: 1
Tehnički fakultet Rijeka	Naziv pozicije: Rotor_kompresora		A3

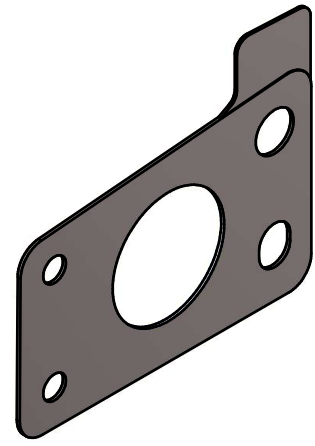
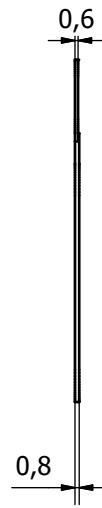
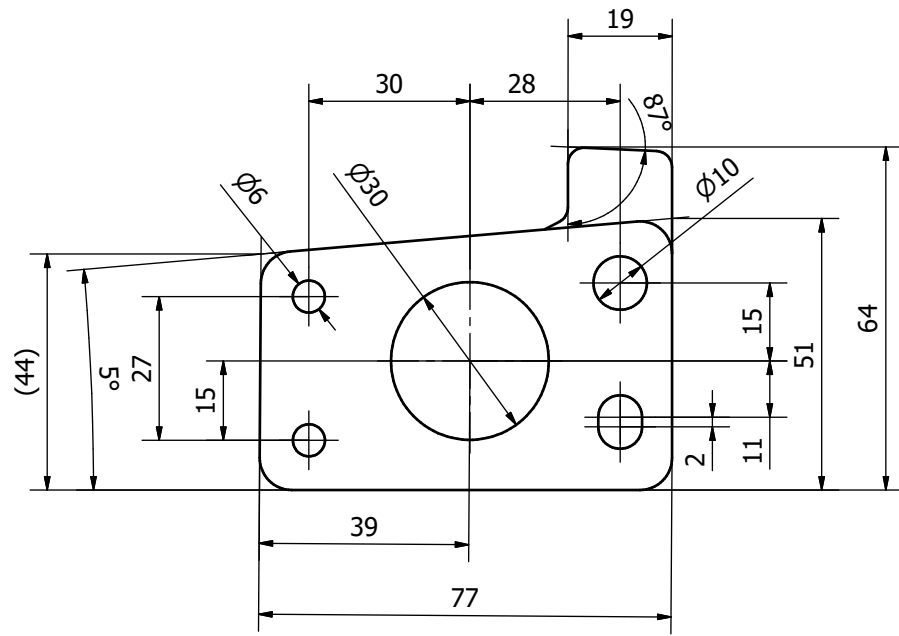

- sva nekotirana zaobljenja izvesti s R = 3

Ime i prezime: Staša Mudri	Obrada površine: Rz 25		Materijal: Nehrdajući čelik	Mjerilo: 1 : 1
	Datum: 03.09.2024.		Broj crteža: 1	
Tehnički fakultet Rijeka	Naziv pozicije: Brtva			A3

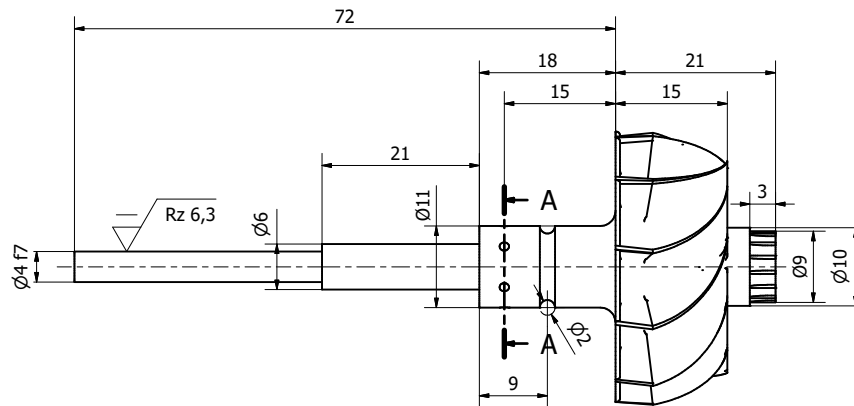
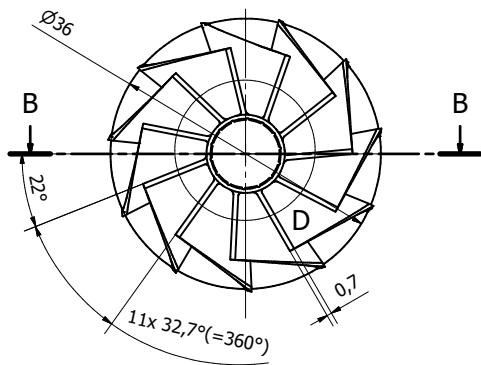

D (4 : 1)

A-A (2 : 1)

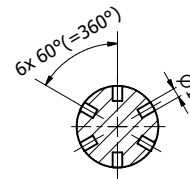
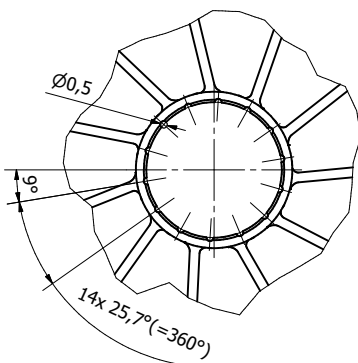

B-B (2 : 1)

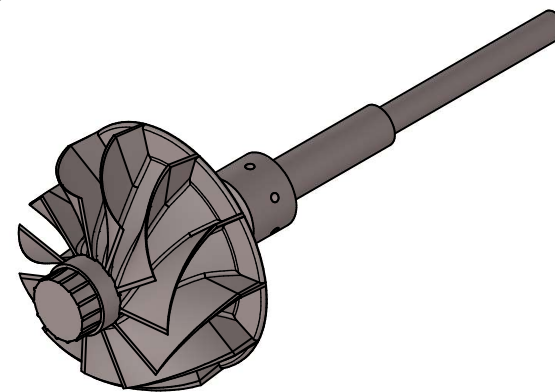
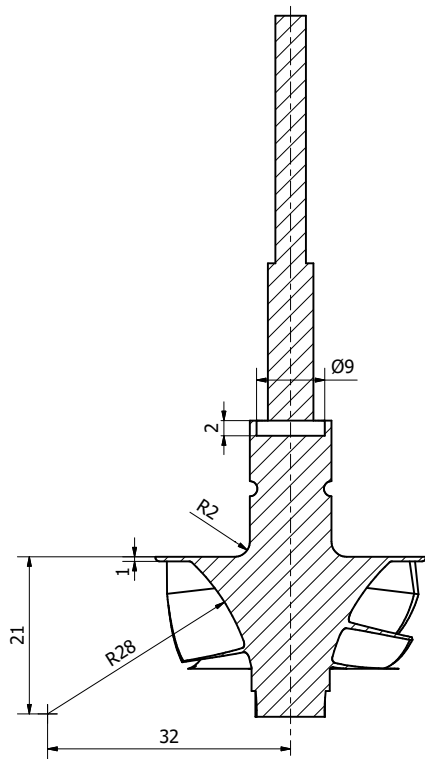

Ime i prezime: Staša Mudri	Obrada površine: Rz 25	Materijal: Aluminij	Mjerilo: 2 : 1
Tehnički fakultet Rijeka	Datum: 03.09.2024.	Broj crteža: 1	A2
Naziv pozicije: Spoj_vratila_i_rotora			



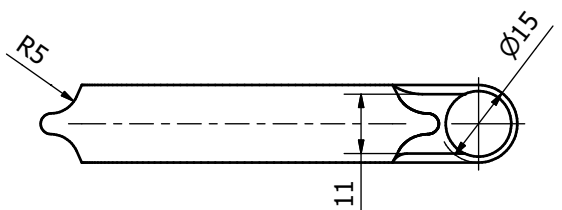
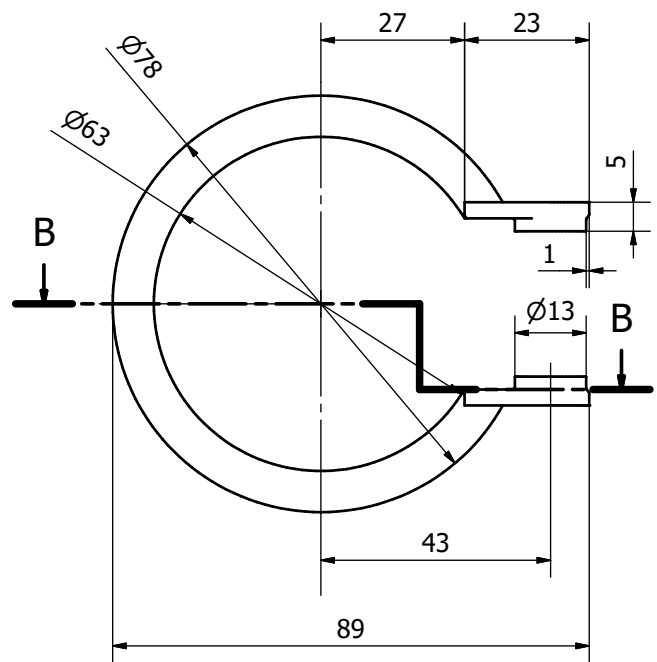

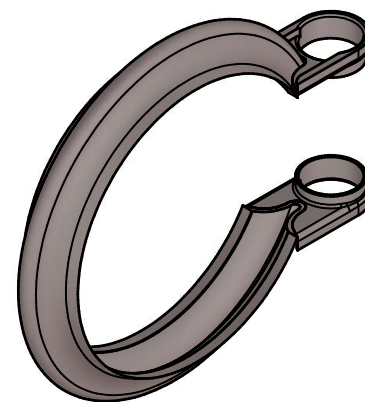
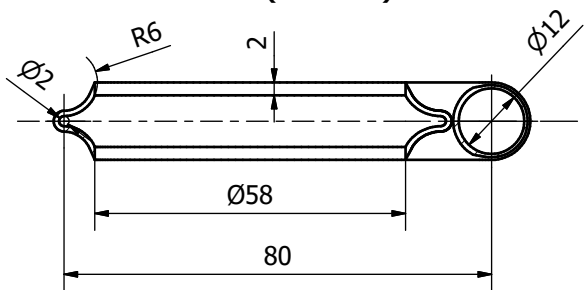

B-B (1 : 1)

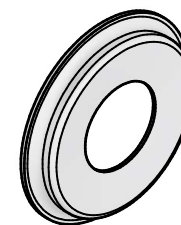
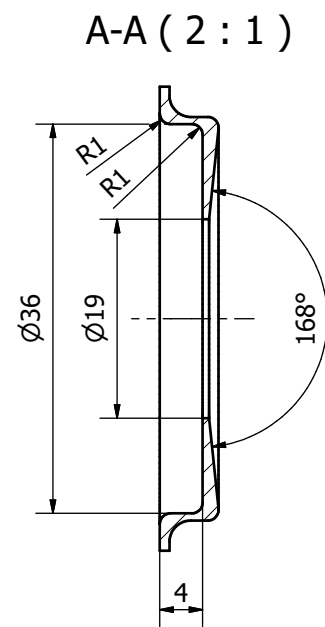
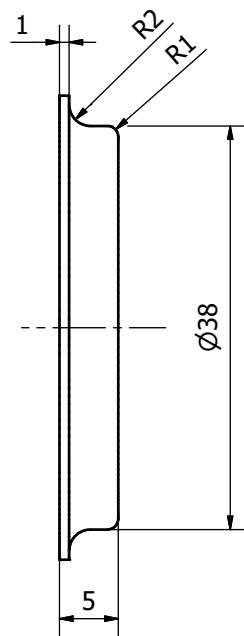
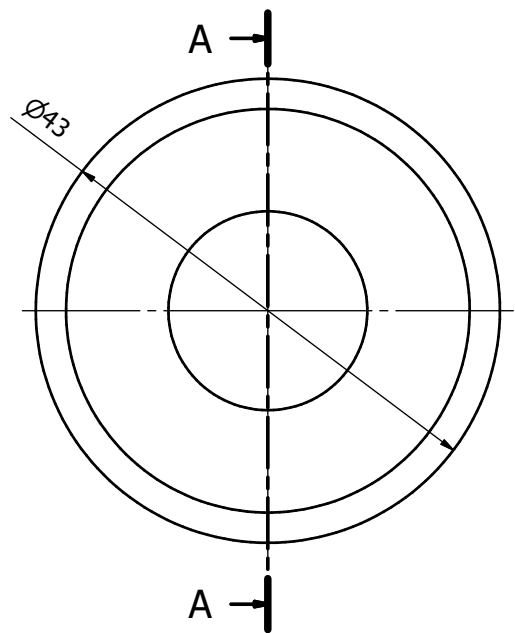

- sva nekotirana zaobljenja izvesti s R = 1

Ime i prezime: Staća Mudri	Obrada površine: Rz 25		Materijal: Nehrđajući čelik	Mjerilo: 1 : 1
	Datum: 03.09.2024.		Broj crteža: 1	
Tehnički fakultet Rijeka	Naziv pozicije: Spojnica		A3	



Ime i prezime: Staša Mudri	Obrada površine:  Rz 25		Materijal: Aluminij	Mjerilo: 2 : 1
	Datum: 03.09.2024.		Broj crteža: 1	
Tehnički fakultet Rijeka	Naziv pozicije: Zastitni_poklopac			A3